

**Fujitsu Storage**  
**ETERNUS SF**  
**Storage Cruiser V16.9.1 /**  
**AdvancedCopy Manager V16.9.1**

**Operation Guide for**  
**VMware vSphere Virtual Volumes**

B1FW-6020-10ENZO(00)  
June 2024

---

# Preface

---

## Purpose of This Manual

This manual explains the method of managing/using the VMware vSphere Virtual Volumes environment using ETERNUS SF Storage Cruiser (hereafter abbreviated as "Storage Cruiser") or ETERNUS SF AdvancedCopy Manager (hereafter abbreviated as "AdvancedCopy Manager").

## Intended Readers

This manual targets the following administrators/users who use Storage Cruiser and AdvancedCopy Manager:

- Storage system administrators who use Virtual Volumes
- Storage system users who use Virtual Volumes (Virtual machine administrators/users)

## Structure of This Manual

The structure of this manual is as follows.

### [Chapter 1 Overview](#)

This chapter explains an overview of VMware vSphere Virtual Volumes.

### [Chapter 2 Design/Installation/Operation/Maintenance by Storage Administrator](#)

This chapter explains the design, deployment, operation, and maintenance of the storage systems that use Virtual Volumes.

### [Chapter 3 Virtual Machine Operation by Virtual Machine Administrator/User](#)

This chapter explains the operation of virtual machines that use Virtual Volumes by Virtual machine administrators/users.

### [Chapter 4 Command References](#)

This chapter explains how to use each command.

## Conventions

- "FUJITSU Storage" and "Fujitsu Storage" are omitted from the names of the products and manuals.
- This manual abides by the conventions listed in "Conventions" in the *ETERNUS SF Express / Storage Cruiser / AdvancedCopy Manager Documentation Road Map*.
- In this manual, the conditions and rules for managing virtual machines and Virtual Volume are called "policy". When showing the policy for vSphere Web Client, it is written as "VM Storage Policies".

## Export Controls

Exportation/release of this document may require necessary procedures in accordance with the regulations of your resident country and/or US export control laws.

## Trademarks

- Microsoft, Windows, Windows Server, Internet Explorer, and Microsoft Edge are trademarks or registered trademarks of Microsoft Corporation in the United States and other countries.
- UNIX is a registered trademark of The Open Group in the United States and other countries.
- Oracle and Java are registered trademarks of Oracle and/or its affiliates. Other names may be trademarks of their respective owners.
- Linux is a registered trademark of Linus Torvalds.
- Red Hat and RPM are registered trademarks of Red Hat, Inc. in the U.S. and other countries.

- Novell is a registered trademark of Novell Inc., and SUSE and the SUSE logo is a trademark, of SUSE LLC, in the United States and other countries.
- HP-UX is a trademark of Hewlett-Packard Company in the United States and other countries.
- AIX is a trademark or a registered trademark of International Business Machines Corporation in the United States and other countries.
- All other brand and product names are trademarks or registered trademarks of their respective owners.

## Revision History

Date of Publication	Revision	Document Part Number	
		PDF	HTML
June 2024	10	B1FW-6020-10ENZ0(00)	B1FW-6020-10ENZ2(00)
September 2023	9	B1FW-6020-09ENZ0(00)	B1FW-6020-09ENZ2(00)
February 2023	8.1	B1FW-6020-08ENZ0(01)	B1FW-6020-08ENZ2(01)
August 2021	8	B1FW-6020-08ENZ0(00)	B1FW-6020-08ENZ2(00)
July 2020	7.2	B1FW-6020-07ENZ0(02)	B1FW-6020-07ENZ2(02)
January 2020	7.1	B1FW-6020-07ENZ0(01)	B1FW-6020-07ENZ2(01)
November 2019	7	B1FW-6020-07ENZ0(00)	B1FW-6020-07ENZ2(00)
April 2019	6.1	B1FW-6020-06ENZ0(01)	B1FW-6020-06ENZ2(01)
December 2018	6	B1FW-6020-06ENZ0(00)	B1FW-6020-06ENZ2(00)
December 2017	5	B1FW-6020-05ENZ0(00)	B1FW-6020-05ENZ2(00)
May 2017	4	B1FW-6020-04ENZ0(00)	B1FW-6020-04ENZ2(00)
October 2016	3	B1FW-6020-03ENZ0(00)	B1FW-6020-03ENZ2(00)
April 2016	2.1	B1FW-6020-02ENZ0(01)	B1FW-6020-02ENZ2(01)
October 2015	2	B1FW-6020-02ENZ0(00)	B1FW-6020-02ENZ2(00)
July 2015	1.2	B1FW-6020-01ENZ0(02)	B1FW-6020-01ENZ2(02)
March 2015	1.1	B1FW-6020-01ENZ0(01)	B1FW-6020-01ENZ2(01)
January 2015	1	B1FW-6020-01ENZ0(00)	B1FW-6020-01ENZ2(00)

## Notes

- No part of this manual may be reproduced without permission.
- This manual is subject to change without advance notice.

## Copyright Notice

Copyright 2015-2024 Fujitsu Limited

## Update History

Content of Update	Updated Section	Revision
The "FUJITSU Storage" part of the product name has been changed to "Fujitsu Storage".	Cover page	10
Information related to the following devices has been added. - ETERNUS DX S6 series	General	

Content of Update	Updated Section	Revision
Information related to the following device and software has been deleted. <ul style="list-style-type: none"> <li>- ETERNUS DX200F</li> <li>- VMware vSphere 6</li> <li>- VMware vCenter Server 6</li> </ul>		
In [Point] in the "Creation of VVOL Access Path", the description has been modified.	2.3.2	
The version information has been changed to V16.9A.	Cover page	9
Information related to the following software has been added. <ul style="list-style-type: none"> <li>- VMware vSphere 8</li> </ul>	1.1	8.1
The function overview article has been deleted from this manual because it was moved to the <i>Overview</i> .	General	8
The version of the required software has been modified.	1.1	
A new section has been added.	2.5.4.3	
The procedure has been modified.	3.2.1	
In "Virtual Machine (Connecting Disk Configuration)" of "Design of Storage System", the condition related to the controller of virtual disks comprising the virtual machine has been added.	2.1.2.1	7.2
Information related to the following device has been added. <ul style="list-style-type: none"> <li>- ETERNUS DX900 S5</li> </ul>	General	7.1
The redundant sentence in the subheading "Creation of Clone Backup VVOL Datastore" has been deleted.	2.3.3	
[Note] has been added.	2.4.1	
Information related to Model Upgrade from the following devices has been added. <ul style="list-style-type: none"> <li>- ETERNUS DX200 S5</li> <li>- ETERNUS DX200 S4</li> <li>- ETERNUS AF250 S3</li> </ul>	2.5.5	
Information related to the following devices has been added. <ul style="list-style-type: none"> <li>- ETERNUS DX S5 series (excluding the ETERNUS DX900 S5)</li> <li>- ETERNUS AF S3 series</li> </ul> Information related to the following software has been deleted. <ul style="list-style-type: none"> <li>- Microsoft Windows Server 2008 R2</li> <li>- Microsoft Windows Server 2008</li> </ul>	General	7
The description for Conventions has been changed so that the <i>ETERNUS SF Express / Storage Cruiser / AdvancedCopy Manager Documentation Road Map</i> is referenced.	"Conventions" in Preface	
The "Manual Organization and Reading Suggestions" section has been deleted from Preface.	Preface	
The version information of ETERNUS VASA Provider has been modified.	1.3	
The subheading "Data Integrity" has been added.	2.4.1	

Content of Update	Updated Section	Revision
Information related to Microsoft Windows Server 2019 has been added.	"Notation" and "Others" in Preface	6.1
In [Note] in the "System Configuration", information has been added.	2.1.1	
[Point] has been added in "Management Server Redundancy" of "Operational Management Environment Redundancy".	2.1.1	
In [Point] in the "Volume for Snapshot backup", information has been added.	2.1.2.1	
In [Point], information has been modified.	2.3.2	
In [Point] in the "Save Generations and Backup History", information has been added.	2.4.1	
Information related to the ETERNUS DX8900 S4 has been added.	"Notation" in Preface, 1.3, 2.3.2	6
In [Note], information has been added.	2.4.6	
Information related to Solaris 9 has been deleted.	"Notation" in Preface	5
Information related to the ETERNUS DX500 S4/DX600 S4 has been added.	"Notation" in Preface, 1.3	
Information related to the ETERNUS AF250 S2/AF650 S2 has been added.	"Notation" in Preface, 1.3	
In [Point], information has been modified.	2.1.1	
In [Note], information has been added.	2.1.1, Chapter 3	
[Information] has been added.	2.5.4	
The explanation about backing up and restoration of ETERNUS VASA Provider has been modified.	2.5.4.1	
The explanation about collecting Troubleshooting Information for ETERNUS VASA Provider has been modified.	2.5.4.2	
Information related to Microsoft Windows Server 2016 has been added.	"Notation" and "Others" in Preface	4
Information related to Windows Vista has been deleted.	"Notation" in Preface	
Information related to SUSE Linux Enterprise Server 11 has been deleted and information related to SUSE Linux Enterprise Server 12 for AMD64 & Intel64 has been added.	"Notation" in Preface	
Information related to the ETERNUS DX100 S4/DX200 S4 has been added.	"Notation" in Preface, 1.3	
The description has been modified so that Microsoft Windows Server 2016 is listed.	2.2.2	
[Point] has been added.	2.3.2	
In [Note] in the "Creation of VVOL Datastore", information has been added.	2.3.3	
Information related to HP-UX 11i v1/v2 has been deleted.	"Notation" in Preface	
Information related to VMware vSphere 4 has been deleted.	"Notation" in Preface	3
Information related to the ETERNUS DX80/DX90 has been deleted.	"Notation" in Preface	
Information related to the ETERNUS AF250/AF650 has been added.	"Notation" and "Others" in Preface, 1.3	
Unnecessary information has been deleted.	2.1.1, 2.1.2.1, 2.2.3, 3.3.1.1	

Content of Update	Updated Section	Revision
[Point] has been added.	2.1.1	
The explanation related to the Automated Storage Tiering policy has been modified.	2.1.2.2	
In [Point], information has been modified.	2.3.2	
New section has been added.	2.5.5	
The explanation of Meaning in the table "VVOL Access Path Status List" has been modified.	2.3.2	2.1
A note related to Windows dynamic disks has been added to [Note].	2.4.2, 3.5.4	
Information that is not restored from Clone backup has been added to [Note].	2.4.2, 3.6.1	
Information related to Microsoft Windows Server 2003 has been deleted.	"Notation" in Preface	2
Information related to Windows 10 has been added.	"Notation" in Preface	
A note has been modified.	1.2	
The table of Operating Environment has been modified.	1.3	
A see has been modified.	2.1.2.1	
"Auto Execution by External Scheduler" has been added.	2.4.1.3	
A point has been added.	2.3.2, 3.3.1.1, 3.3.2.1	
"Command References" has been added.	Chapter 4	
Information related to the ETERNUS DX8700 S3/DX8900 S3 has been added.	"Notation" in Preface, 1.3	
The optional license name has been modified.	1.3	
The description of the upper limit of Tier pools that can be managed by Automated Storage Tiering has been added.	2.1.2.2	
The term "VMware Virtual Volumes" has been changed to "VMware vSphere Virtual Volumes" according to the terms used by VMware, Inc.	Throughout this manual	1.1
Information related to VMware vSphere 6 has been added.	"Notation" in Preface	
The terms of "policy" and "VM Storage Policies" have been added.	"Others" in Preface	
"VVOL Access Path Management", "VVOL Datastore Configuration Management" and "Virtual Machine Backup" have been modified.	1.2	
"Operating Environment" table has been modified. Point has been modified.	1.3	
Information has been added.	Chapter 2	
Point and note in "System Configuration" have been modified. "Management Server Redundancy" has been modified. "Network Redundancy" has been modified.	2.1.1	
"Virtual Machine Backup Policy" table has been modified. Point in "Clone Backup VVOL Datastore" has been modified.	2.1.2.1	
Item in "Automated QoS Policy" table has been renamed.	2.1.2.3	
Table of policies has been added.	2.1.2.4, 2.1.2.5	
Information has been added.	2.1.2.5	

Content of Update	Updated Section	Revision
Note has been added. "To Create Management Server in vSphere HA Environment" has been added.	2.2.1	
Procedure has been modified.	2.2.2	
"FC Switch" has been modified.	2.2.3	
"Virtual Volume Type" table has been modified. "Repository" in "Configuration Information" has been modified. Note and see have been modified.	2.3.1	
"VVOL Access Path Status List" table has been modified. Point in "Display of VVOL Access Path Usage State" has been modified.	2.3.2	
Point and note in "Creation of VVOL Datastore" have been added. "Creation of Clone Backup VVOL Datastore" has been modified. "Display of VVOL Datastore Usage Status" has been added. Point in "Configuration Change of VVOL Datastore" has been added. Note in "Configuration Change of VVOL Datastore" has been modified.	2.3.3	
Point has been modified.	2.3.6	
Table of policy and point have been added.	2.3.7, 2.3.8	
"Cache Management" has been added.	2.3.9	
"Policy Settings to Create Backup" table has been added. Point has been modified. "Save Generations and Backup History" has been modified. Configuration value of task name in table in "Auto Execution (Auto Backup)" has been modified.	2.4.1	
Table of the method of restoring has been modified. "Restoration from Snapshot Backup" has been modified. Note in "Restoration from Clone Backup" has been modified. "Single Item Restore" has been modified. The confirm method of the execution status of the physical copy by OPC that had been described in point has been modified. Note in "Regarding Temporary Volume for Single Item Restore Connected to Virtual Machine" has been modified.	2.4.2	
Attribute of temporary volume has been modified.	2.4.2, 3.5.4	
Description of secondary backup has been added. Note has been added. The confirm method of Clone backup volume information has been modified. See has been modified.	2.4.6	
The backup and restore procedure when the Management Server is constructed on a virtual machine has been added.	2.5.4.1	
Note has been added. Information has been modified.	Chapter 3	
"Preparatory Work" has been added. "Creating Virtual Machine" has been modified. "Applying Policy" and "Changing Policy" have been deleted.	3.1.2	
The vSphere Web Client operating procedure has been modified.	3.2.1, 3.3.1, 3.3.1.1, 3.3.2, 3.3.3, 3.4.1, 3.5.1, 3.5.2, 3.5.3, 3.5.5	
"Validation of Policy Function" has been deleted.	3.3	

Content of Update	Updated Section	Revision
Point has been modified. "Policy Application and Applicable Scope" and "Policy Operating Condition" have been added.	3.3.1	
The descriptions of Operation Mode, Number of Snapshot Generations, and Clone Backup in the Property List table have been modified. "Policy Application and Range of Application", "Confirming Application of Policy", and "Policy Change" have been deleted. "About Backup Targets" has been modified.	3.3.1.1	
"Property List" table has been modified.	3.3.1.2, 3.3.1.3, 3.3.1.5	
"When Changing the Policy for Only One Virtual Machine" and "When Changing the Policy All at One Time" have been added. The vSphere Web Client operating procedure in "When applying other policy to a virtual machine" and "When editing policies" has been modified. The description of the policy change has been added. Note has been modified.	3.3.2	
"Virtual Machine Backup" has been added.	3.3.2.1	
"Automated Storage Tiering (Advanced)" has been added.	3.3.2.2	
"Automated QoS (Advanced)" has been added.	3.3.2.3	
"Cache (Advanced)" has been added.	3.3.2.4	
"Security (Advanced)" has been added.	3.3.2.5	
The vSphere Web Client operating procedure has been modified. Conditions and action for "Noncompliant" displayed in Compliance Status have been added.	3.3.3	
"Deletion of Policy" has been added.	3.3.4	
Point and note have been modified.	3.4.1	
"Migration of Virtual Machine" has been added.	3.4.3	
The conditions to execute Single item restore have been listed. The procedure for Single item restore from Snapshot has been modified. Note has been modified.	3.5.4	
Note has been modified. The procedure for restore from Clone backup has been modified.	3.6.1	



# Contents

---

Chapter 1 Overview.....	1
1.1 Operating Environment.....	1
1.2 Flow from Installation to Operation.....	2
1.2.1 Definition and Role of Administrator/User.....	2
1.2.2 Flow from Installation to Operation.....	3
Chapter 2 Design/Installation/Operation/Maintenance by Storage Administrator.....	5
2.1 Operational Design of Storage System.....	5
2.1.1 Initial Design of System Configuration.....	5
2.1.2 Policy Design.....	8
2.1.2.1 Virtual Machine Backup.....	9
2.1.2.2 Automated Storage Tiering (Advanced).....	10
2.1.2.3 Automated QoS (Advanced).....	11
2.1.2.4 Cache (Advanced).....	11
2.1.2.5 Security (Advanced).....	12
2.2 Installation and Configuration of ETERNUS SF Manager.....	12
2.2.1 Installation of ETERNUS SF Manager.....	13
2.2.2 Configuration of ETERNUS SF Manager.....	14
2.2.3 Configuration and Registration of Managed Devices.....	15
2.2.4 Configuration of Advanced Copy Connection Type.....	16
2.2.5 Configuration of VVOL Access Path.....	16
2.2.6 Creation of VVOL Datastore.....	16
2.3 Operation of Storage System.....	17
2.3.1 Resource Management.....	17
2.3.2 VVOL Access Path Management.....	18
2.3.3 VVOL Datastore Management.....	20
2.3.4 Event Display.....	23
2.3.5 Performance Management.....	23
2.3.6 Correlation Management.....	24
2.3.7 Automated Storage Tiering.....	24
2.3.8 Automated QoS.....	25
2.3.9 Cache Management.....	25
2.4 Backup Operation of Virtual Machine.....	25
2.4.1 Backup.....	26
2.4.1.1 Auto Execution (Auto Backup).....	29
2.4.1.2 Manual Execution.....	30
2.4.1.3 Auto Execution with External Scheduler.....	30
2.4.2 Restoration.....	33
2.4.3 Reference/Deletion of Backup History.....	40
2.4.4 Change of Backup Policy.....	41
2.4.5 Configuration Change of Backup Environment.....	41
2.4.6 Secondary Backup of Clone backup and Data Use on Other Storage Devices.....	41
2.4.7 Notes on Operation.....	42
2.5 Configuration Change/Maintenance of Storage System.....	42
2.5.1 Management Server Environment Configuration Change.....	42
2.5.2 VVOL Datastore Configuration Change.....	43
2.5.3 VMware Environment Configuration Change.....	43
2.5.4 Maintenance of Management Server.....	44
2.5.4.1 Backup/Restoration of Management Server Environment.....	44
2.5.4.2 Collecting Troubleshooting Information.....	45
2.5.4.3 Starting and Stopping the Services.....	46
2.5.5 Changing Configuration of Supported Devices.....	46
Chapter 3 Virtual Machine Operation by Virtual Machine Administrator/User.....	47
3.1 Virtual Machine Operation in VMware vSphere Virtual Volumes Environment.....	47
3.1.1 Summary of Operation.....	47

3.1.2 Operating Procedure.....	48
3.2 Operation of VVOL Datastores.....	49
3.2.1 Registration of VVOL Datastores.....	49
3.3 Operation of Policies.....	49
3.3.1 Creation of Policy.....	49
3.3.1.1 Virtual Machine Backup.....	51
3.3.1.2 Automated Storage Tiering (Advanced).....	54
3.3.1.3 Automated QoS (Advanced).....	56
3.3.1.4 Cache (Advanced).....	58
3.3.1.5 Security (Advanced).....	58
3.3.2 Change of Policy.....	59
3.3.2.1 Virtual Machine Backup.....	60
3.3.2.2 Automated Storage Tiering (Advanced).....	61
3.3.2.3 Automated QoS (Advanced).....	61
3.3.2.4 Cache (Advanced).....	62
3.3.2.5 Security (Advanced).....	62
3.3.3 Confirmation of Policy Application.....	62
3.3.4 Deletion of Policy.....	64
3.4 Operation of Virtual Machine.....	64
3.4.1 Creation of Virtual Machine.....	64
3.4.2 Deletion of Virtual Machine.....	65
3.4.3 Migration of Virtual Machine.....	65
3.5 Snapshot.....	66
3.5.1 Creation of Snapshot.....	66
3.5.2 Reference to Snapshot List.....	66
3.5.3 Reversion to Snapshot.....	66
3.5.4 Single Item Restore From Snapshot.....	67
3.5.5 Deletion of Snapshot.....	69
3.6 Restoration.....	69
3.6.1 Restore at Time of Physical Failure.....	69
Chapter 4 Command References.....	71
4.1 esfadm esfdata (Configuration Information Operation Command).....	71
4.2 esfadm vvolvm info (Virtual Machine Information Display Command).....	71
4.3 esfadm vvolvm backup (Virtual Machine Backup Command).....	72

# Chapter 1 Overview

## 1.1 Operating Environment

VMware vSphere Virtual Volumes are available in the following environments.

Table 1.1 Operating Environment

Target	Environment
Platform	Windows environment platform where ETERNUS SF Manager is operating
Required Software	<ul style="list-style-type: none"> <li>- ETERNUS SF Storage Cruiser</li> <li>- ETERNUS VASA Provider (*1, *2)                             <ul style="list-style-type: none"> <li>- When using Version 2: Version 2.1.13 or later is required.</li> <li>- When using Version 3: Version 3.0.9 or later is required.</li> </ul> </li> <li>- VMware vSphere 7 or later</li> <li>- VMware vCenter Server 7 or later</li> </ul>
Optional Software	ETERNUS SF AdvancedCopy Manager Required when using the virtual machine backup function.
Required License	ETERNUS SF Storage Cruiser Standard Edition
Optional Licenses	<ul style="list-style-type: none"> <li>- ETERNUS SF AdvancedCopy Manager Local Copy License Required when using the virtual machine backup function.</li> <li>- ETERNUS SF Storage Cruiser Optimization Option (*3) Required when using Automated Storage Tiering.</li> <li>- ETERNUS SF Storage Cruiser Quality of Service Management Option Required when using Automated QoS.</li> </ul>
Connection Configuration with the Business Server	<ul style="list-style-type: none"> <li>- Connection through Fibre Channel</li> <li>- Connection through iSCSI</li> </ul>
Storage Devices	ETERNUS DX S6/S5/S4 series (excluding the ETERNUS DX60 S5/S4) (*4) ETERNUS DX S3 series (excluding the ETERNUS DX60 S3) (*4,*5) ETERNUS AF All-Flash Arrays (*4)

\*1: ETERNUS VASA Provider is included in the ETERNUS VMware Support Package. Refer to the *Installation and Setup Guide* for installation details about ETERNUS VMware Support Package.

\*2: When you use VMware vSphere 8, ETERNUS VASA Provider 3.0.10 or later is required.

\*3: Not required when using one layer Tier pool alone.

\*4: Two CM models are required.

\*5: Firmware version numbers that support the VMware vSphere Virtual Volumes function is required.

### Point

- ETERNUS SF Manager and ETERNUS VASA Provider must be installed in the same server.
- VMware vCenter Server must be installed on a server different from the one where ETERNUS SF Manager and ETERNUS VASA Provider are installed.
- This product automatically creates one FTV of the capacity shown in the table below for each storage device in a Tier pool constituting a VVOL datastore so as to store the configuration information about the Virtual Volumes on the storage device.

Storage Device Name	Required Disk Space (Unit: MB)
ETERNUS DX600 S6 ETERNUS DX100 S5/DX200 S5, DX500 S5/DX600 S5 ETERNUS DX100 S4/DX200 S4, DX500 S4/DX600 S4 ETERNUS DX100 S3/DX200 S3, DX500 S3/DX600 S3 ETERNUS AF All-Flash Arrays	1,040
ETERNUS DX900 S6, DX8900 S6 ETERNUS DX900 S5 ETERNUS DX8900 S4 ETERNUS DX8700 S3/DX8900 S3	4,160

---

## 1.2 Flow from Installation to Operation

### 1.2.1 Definition and Role of Administrator/User

---

#### Storage Administrator

Manages storage related resources/operations, and provides storage users with storage resources.

OS administrator privileges are required for storage administrators.

#### Storage User (VM Administrator/VM User)

##### VM Administrator

The virtual machine administrator manages the resources and operations associated with virtual machines and provides virtual machines to VM users.

An administrator who has administrator privileges for VMware management functions (VMware vCenter Server).

##### VM User

A business administrator or a business user who uses virtual machines.

Required privileges are granted by a VM administrator to use the VMware management functions (VMware vCenter Server).

## 1.2.2 Flow from Installation to Operation

Figure 1.1 Flow from Installation to Operation

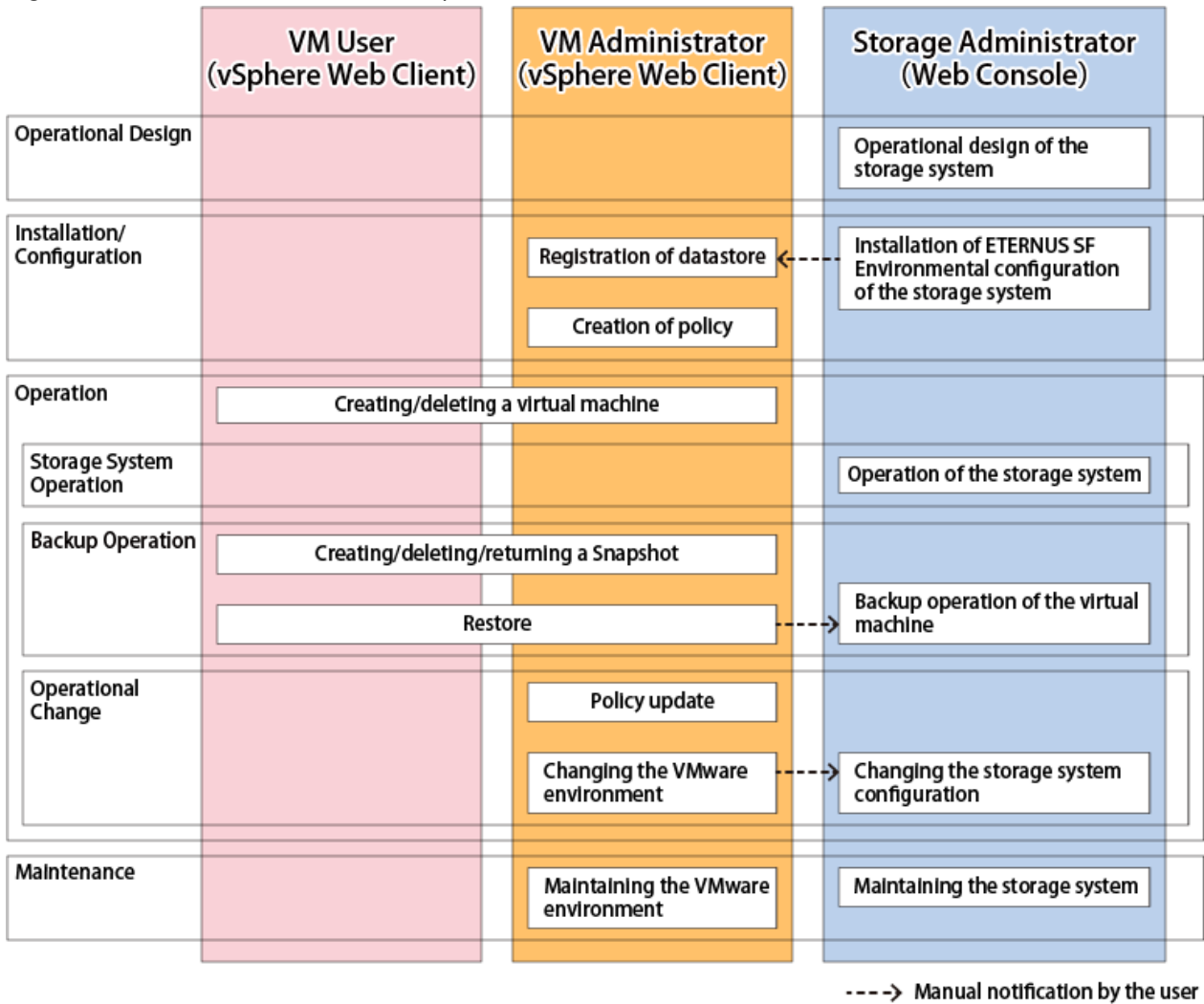

Table 1.2 Work Items and References of the Storage Administrator

Phase	Work Item	Reference
Operational Design	Operational design of the storage system	"2.1 Operational Design of Storage System"
Installation/Configuration	Installation of ETERNUS SF Manager Environmental configuration of the storage system	"2.2 Installation and Configuration of ETERNUS SF Manager"
Storage System Operation	Operation of the storage system	"2.3 Operation of Storage System"
Backup Operation	Backup operation of the virtual machine	"2.4 Backup Operation of Virtual Machine"
Operational Change	Changing the storage system configuration	"2.5 Configuration Change/Maintenance of Storage System"
Maintenance	Maintaining the storage system	"2.5 Configuration Change/Maintenance of Storage System"

Table 1.3 Work Items and References of VM Administrator/User

Phase	Work Item	Reference
Installation/ Configuration	Registration of the datastore	"3.2.1 Registration of VVOL Datastores"
	Creation of policy	"3.3.1 Creation of Policy"
Operation	Creating/deleting the virtual machine	"3.4 Operation of Virtual Machine"
Backup Operation	Creating/deleting/returning of Snapshot	"3.5 Snapshot"
	Restoration	"3.5.3 Reversion to Snapshot" "3.6 Restoration"
Operational Change	Policy update	"3.3.2 Change of Policy"
	Changing the VMware environment	"3.3.3 Confirmation of Policy Application"
Maintenance	Maintaining the VMware environment	Refer to the VMware manuals for VMware environment maintenances.

# Chapter 2 Design/Installation/Operation/Maintenance by Storage Administrator

This chapter describes the design, installation, operation, and maintenance of storage system that use VMware vSphere Virtual Volumes by the storage administrator.

## Information

The terms related to vSphere mentioned in this chapter may vary with the version level of vSphere.

## 2.1 Operational Design of Storage System

This section describes the operational design of storage systems that use the VMware vSphere Virtual Volumes.

### 2.1.1 Initial Design of System Configuration

This section describes the system configuration required to install and operate this product.

#### See

This document describes the VMware vSphere Virtual Volumes environment. Refer to "Operation Design" in the *Storage Cruiser Operation Guide* for details on the operational design of the entire system.

#### System Configuration

Figure 2.1 Example System Configuration

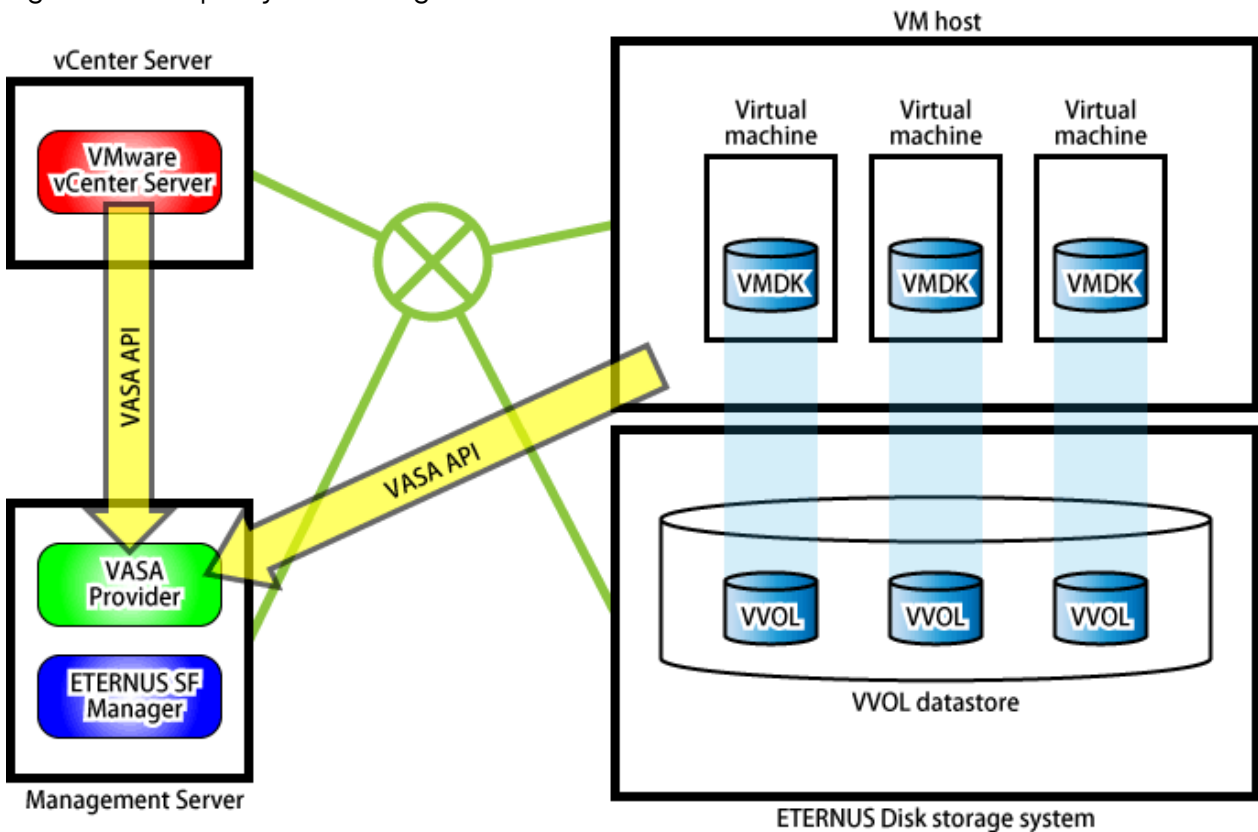

## Management Server

Management Servers are required to configure the operational environment of VMware vSphere Virtual Volumes. ETERNUS SF Manager and ETERNUS VASA Provider must be installed on the Management Server.

## Virtual Machine

The virtual machine is to be connected to the created Virtual Volume. Additionally, this is the virtual machine to be backed up with the backup function. VMware Tools must be installed in the virtual machine.

## VMware ESX Host (VM Host)

This server provides virtual machines an execution environment.

## VMware vCenter Server

This server manages and operates virtual machines.

### Point

Multiple ETERNUS VASA Providers can be managed by a single VMware vCenter Server. In addition, multiple VMware vCenter Servers can manage a single ETERNUS VASA Provider.

### Note

- Ensure the Management Server, VMware vCenter Server, and VM host can mutually confirm FQDN with DNS service.
- Synchronize the timestamps for the Management Server, VMware vCenter Server, VM host, and ETERNUS Disk storage system using an NTP service.
- To manage a single ETERNUS VASA Provider with multiple VMware vCenter Servers, ETERNUS VASA Provider that supports Multi vCenter Server is required. Refer to the ETERNUS VASA Provider manual for details about Multi vCenter Server.
- In a configuration that manages a single ETERNUS VASA Provider with multiple VMware vCenter Servers, do not register the same VVOL datastore in the multiple VMware vCenter Servers.
- The host name of the Management Server must be a name that can be specified as the FQDN name in ETERNUS VASA Provider. For details about the available FQDN names for ETERNUS VASA Provider, refer to the ETERNUS VASA Provider manuals.

## Operational Management Environment Redundancy

In the VMware vSphere Virtual Volumes environment, the following operations are affected if a failure occurs in the operational management environment. Therefore, it is recommended that the operations management environment is made redundant.

- Operations that use the functions of this product (such as virtual machine backup)
- Changing the system configuration (such as starting/stopping virtual machines and adding/deleting/moving Virtual Volumes)

### Point

Even if a failure occurs in an operational environment, the currently operating virtual machine can continue to be used.

## VMware vCenter Server Redundancy

Refer to the VMware vCenter Server manuals.



## Management Server Redundancy

Redundancy is achieved by VMware vSphere High Availability (vSphere HA).

Figure 2.2 Example of vSphere HA Configuration

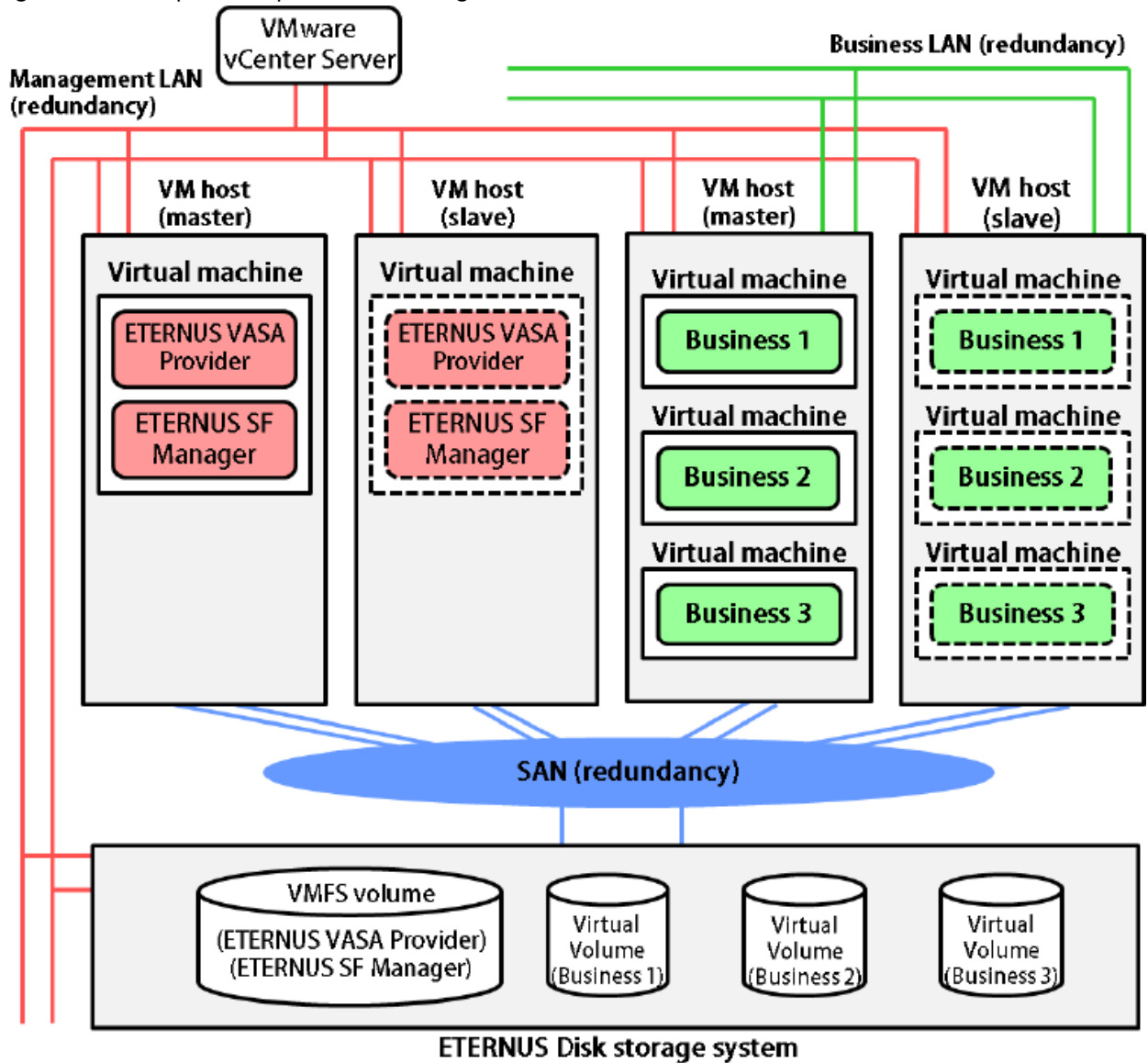

In vSphere HA, achieve redundancy by configuring the Management Server on the virtual machine. The business VMware environment and operational management VMware environment can be managed by one VMware vCenter Server.

In the above example, we use four VM hosts and divide these into VM hosts for the Management Server and VM hosts for the business server. It is possible to configure this with just two VM hosts and share the Management Server and the business server.

### Point

.....  
If a failover occurs at the same time on both the Management Server and the business server, the business server may not be able to start normally. If the Management Server and the business server are configured on the same VM host, the risk of both servers performing a failover simultaneously increases. Therefore, it is recommended that you configure the Management Server and the business server on separate VM hosts as shown in "Figure 2.2 Example of vSphere HA Configuration".  
.....



### See

Refer to the VMware vSphere manuals for information on how to configure the vSphere HA environment.

## Network Redundancy

It is recommended to make business LAN and management LAN redundant.

The Management Server and the business server are made redundant using NIC teaming. In the ETERNUS Disk storage system, as there is a management LAN in CM, the management LAN can be made redundant through redundancy of CM.



### See

- Refer to the VMware vSphere manuals for NIC teaming configuration method as to the VM host.
- Refer to the ETERNUS Disk storage system manuals for configuration method to make the management LAN connected the ETERNUS Disk storage system redundant.

## 2.1.2 Policy Design

In the VMware vSphere Virtual Volumes environment, the storage user can control storage by policy, in accordance with the operation purposes for the virtual machine.

The VVOL datastore assigning the virtual machine is selected and the created virtual machine and Virtual Volume are set according to the content of the policy.



### Information

With VMware vSphere Virtual Volumes, the policies related to storage are called "VM Storage Policies".

The storage administrator should design the storage so that the storage user can control the following functions by using policies:

- Virtual Machine Backup
- Automated Storage Tiering (Advanced)
- Automated QoS (Advanced)
- Cache (Advanced)
- Security (Advanced)



### Point

When using functions described as "Advanced", understanding the storage and function mechanism is necessary. In order for the storage user to operate the virtual machine without awareness of functions described as "Advanced", the storage administrator should create the VVOL datastore in line with the operation purpose, and attach a name based on the operation purpose. We recommend operation by the storage user to be based on the operation purpose, and use of the name to select a VVOL datastore.



### See

Refer to "3.3 Operation of Policies" for operation by a storage user.

## 2.1.2.1 Virtual Machine Backup

This section describes the virtual machine backup policies.

This policy is related to the backup of the virtual machine created in the VVOL datastore.

Policies of virtual machine backup are set by virtual machine unit, not by Virtual Volume unit. Storage users can set the following items as part of the policy.

Table 2.1 Virtual Machine Backup Policy

Item	Explanation
Operation Mode	Operating mode for specifying the virtual machine backup function operating method.
Execution Period	Interval for executing automatic execution of backup.
Execution Interval(Hour)	Interval at which automatic execution of backup is performed when "Hourly" is specified for <b>Execution Period</b> .
Execution Week	Day of the week on which automatic execution of backup is performed when "Weekly" is specified for <b>Execution Period</b> .
Execution Day	Day on which automatic execution of backup is performed when "Monthly" is specified for <b>Execution Period</b> .
Execution Start Time(Hour)	Time (hour) at which the automatic execution of backup will start.
Execution Start Time(Minute)	Time (minute) at which the automatic execution of backup will start.
Number of Snapshot Generations	Number of Snapshot backup save generations.
Quiesce guest file system	Settings of whether file systems are made consistent at backup.
Snapshot the virtual machine's memory	Settings of whether memory contents are included at Snapshot backup.
Clone Backup	Settings of whether Clone backup is created.



See

- Refer to "3.3.1.1 Virtual Machine Backup" for details on each item.
- When performing an automatic backup with an external scheduler, refer to "Point" in "3.3.1.1 Virtual Machine Backup".

## Design of Storage System

This explains the storage system design required for virtual machine backup.

### ETERNUS Disk Storage System

To use the virtual machine backup function, register the ETERNUS SF AdvancedCopy Manager Local Copy License in the ETERNUS Disk storage system on which the virtual machine or Virtual Volume connected to the virtual machine is to be created.

When Virtual Volumes of multiple ETERNUS Disk storage systems are connected to one virtual machine, the license described above is required for all ETERNUS Disk storage systems.

### Virtual Machine (Connecting Disk Configuration)

Perform the backup in virtual machine units. The targets of backup are the virtual disks comprise the virtual machine.

The following conditions must be satisfied:

- The datastore that stores the virtual machine configuration information (datastore selected when creating the virtual machine) is a VVOL datastore.
- The virtual machine comprises virtual disks whose controller is not an NVMe controller.

- All virtual machine disks comprising the virtual machine are Virtual Volumes.

 **Note**

- Virtual disks other than Virtual Volumes will not be the target of backup/restoration based on type/settings. Refer to the following table for details.

Table 2.2 Operation of Disks Other Than Virtual Volumes

	Snapshot Backup, Restoration from Snapshot Backup	Clone Backup, Restoration from Clone Backup	File Unit Restoration
Virtual Volume	Y	Y	Y
VMFS	Y	N	N

Y: Target of backup/restoration  
 N: Not target of backup/restoration

- If in Independent (Persistent/Nonpersistent) mode, the volume will not be the target of backup/restoration.
- In restorations from a Clone backup, connection configurations of virtual disks excluded from a backup/restoration are not restored. Reconnect from VMware vCenter Server as necessary.

Volume for Snapshot backup

This volume is the destination volume for backup when creating a Snapshot backup. When creating the Snapshot backup, it is automatically located in same VVOL datastore as the backup source Virtual Volume.

 **Point**

The free space required on the VVOL datastore is the volume of update data from the time of the Snapshot backup until the time of the next Snapshot backup. When performing N generations of Snapshot backup, the capacity required in the VVOL datastore is the volume of the updated data for the backup source Virtual Volume until the Nth generation Snapshot backup is completed. However, if the Allocation setting of the backup source Virtual Volume is "Thick", the VVOL datastore requires free space greater than or equal to the backup source Virtual Volume.

Clone Backup VVOL Datastore

This is the VVOL datastore for Clone backup. When creating a Clone backup, create one Clone backup VVOL datastore on the ETERNUS Disk storage system beforehand. Create a datastore on all ETERNUS Disk storage systems on which a VVOL datastore for which Clone backup creation is enabled exists.

 **Point**

The required free capacity for the Clone backup VVOL datastore is the same as the capacity of the backup source Virtual Volume.

Volume for Clone Backup

This volume is the destination volume for backup when creating a Clone backup. When creating a Clone backup, this is automatically allocated from the VVOL datastore for Clone backup.

### 2.1.2.2 Automated Storage Tiering (Advanced)

This section describes the Automated Storage Tiering policies.

This policy is related to the Tier pools that make up the VVOL datastore and Automated Storage Tiering for the created Virtual Volume. Use this policy when you operate Automated Storage Tiering across two or more tiers.

When providing the Automated Storage Tiering function to storage users, apply the ETERNUS SF Storage Cruiser Optimization Option license and create a VVOL datastore including the Tier pools to which the Tiering policy is applied.

Storage users can set the following items as part of the policy.

Table 2.3 Automated Storage Tiering Policy

Item	Explanation
Number of Layers	Number of Tier pool layers that comprise the VVOL datastore
Execution Mode	Method of operating Automated Storage Tiering
Priority FTSP	Priority assignment by sub-pool of data written to Virtual Volumes
Low Quota Share (%)	Low sub-pool quota share at time of relocation
Middle Quota Share (%)	Middle sub-pool quota share at time of relocation
High Quota Share (%)	High sub-pool quota share at time of relocation

As **Number of Layers** and **Execution Mode** are determined by the Tier pool configuration designed beforehand and the content that can be set by the storage users, configure the Tiering policy and Tier pool according to the content provided to the storage users.



- There is an upper limit to the number and capacity of Tier pools that can be managed by Automated Storage Tiering. Refer to "Upper Limit of Automated Storage Tiering" in the *Installation and Setup Guide* for details.
- Refer to the *Storage Cruiser Operation Guide for Optimization Function* for details on Automated Storage Tiering.

### 2.1.2.3 Automated QoS (Advanced)

This section describes the Automated QoS policies.

This policy is related to Automated QoS on the created Virtual Volume.

When providing the Automated QoS function to storage users, apply the ETERNUS SF Storage Cruiser Quality of Service Management Option license.

Storage users can set the following items as part of the policy.

Table 2.4 Automated QoS Policy

Item	Explanation
Automated QoS Enable/Disable	Item that sets whether to use Automated QoS or not
Automated QoS:Priority	Priority of Automated QoS
Target Response Time (msec)	Targeted value for response time
Tune by Quota Share	Set whether to enable linking of Automated Storage Tiering



Refer to the *Storage Cruiser Operation Guide for Optimization Function* for details on Automated QoS.

### 2.1.2.4 Cache (Advanced)

This section describes the Cache policies.

This policy is related to the Extreme Cache setting or Extreme Cache Pool setting for the created Virtual Volume.

If the Extreme Cache or Extreme Cache Pool is loaded on the ETERNUS Disk storage system, the storage users can select to use these caches as part of the policy according to the purpose.

Storage users can specify the following item as a policy.

Table 2.5 Cache Policy

Item	Explanation
Extreme Cache	Specified whether to use the Extreme Cache function.



See

Refer to "Extreme Cache Management" in the *Storage Cruiser Operation Guide* for details about Extreme Cache and/or Extreme Cache Pool.

### 2.1.2.5 Security (Advanced)

This section describes the Security policies.

This policy is related to the Data encryption for the created Virtual Volume.

When providing the encryption function to storage users, prepare a VVOL datastore composed of an encrypted Tier pool.

Storage users can specify the following item as a policy.

Table 2.6 Security Policy

Item	Explanation
Data encryption	Specified whether to create an encrypted Virtual Volume.



See

Refer to "Encryption Mode Management" in the *Storage Cruiser Operation Guide* for details about encryption function.

## 2.2 Installation and Configuration of ETERNUS SF Manager

This describes the procedures for installing and configuring ETERNUS SF Manager.

Table 2.7 Required Procedures for Installation and Environment Configuration

Procedure Name	Procedure Details	Procedure Required/Not Required
<a href="#">Installation of ETERNUS SF Manager</a>	-	Required
<a href="#">Configuration and Registration of Managed Devices</a>	-	Required (*1)
<a href="#">Configuration of Advanced Copy Connection Type</a>	-	Required when performing virtual machine backup
<a href="#">Configuration of VVOL Access Path</a>	-	Required
<a href="#">Creation of VVOL Datastore</a>	<a href="#">Creation of Tier Pool</a>	Required
	<a href="#">Creation of VVOL Datastore</a>	Required
	<a href="#">Creation of Clone Backup VVOL Datastore</a>	Required when performing virtual machine backup and creating Clone backup

\*1: It is necessary to register the license according to the function to use. Refer to "[1.1 Operating Environment](#)" for details.

## 2.2.1 Installation of ETERNUS SF Manager

---

When using a Virtual Volume, install the following two programs on the same server, and configure the environment of the Management Server:

- ETERNUS SF Manager
- ETERNUS VASA Provider



.....

ETERNUS VASA Provider is included in the ETERNUS VMware support package. Refer to the *Installation and Setup Guide* for installation details about the ETERNUS SF Manager and ETERNUS VMware Support Package.

.....



.....

Do not manage one ETERNUS Disk storage system with multiple Management Servers.

.....

### To Create Management Server in vSphere HA Environment

Use two VM hosts to create a vSphere HA environment.

Take the following steps to create the environment:

1. Create a Management Server.
  - a. Create for one VM host a VMFS datastore using local disks of the VM host.
  - b. For the created VMFS datastore, create a virtual machine used for a Management Server.
  - c. In the virtual machine for the Management Server, install and set up ETERNUS SF Manager and ETERNUS VASA Provider.
2. Create a shared disk for vSphere HA.
  - a. Register an ETERNUS Disk storage system on the ETERNUS SF system.
  - b. Use the ETERNUS SF system to create volumes on the ETERNUS Disk storage system.
  - c. Use the ETERNUS SF system to locate the created volumes to the two VM hosts respectively.
  - d. Create a VMFS datastore with the located volumes.
3. Create a vSphere HA environment.

Create a vSphere HA environment. At this time, specify the created VMFS datastore for the shared storage.
4. Move the Management Server to the shared disk.

Move the virtual machine for Management Server to the shared disk used for vSphere HA environment.



- .....
- Refer to "Installation of ETERNUS SF Manager" and "Setup of ETERNUS SF Manager" in the *Installation and Setup Guide* to install and set up ETERNUS SF Manager.
  - Refer to "Registering Device" in the *Storage Cruiser Operation Guide* to register the ETERNUS Disk storage system.
  - Refer to "Create Volume" in the *Web Console Guide* for the procedure to create volumes.
  - Refer to "Assign ETERNUS Disk Storage System Volumes to Server" in the *Web Console Guide* for the procedure to locate volumes.
  - Refer to the VMware vSphere manuals to create vSphere HA.
- .....

## 2.2.2 Configuration of ETERNUS SF Manager

If something goes wrong with any of the various services of ETERNUS SF Manager and ETERNUS VASA Provider, the operations of VM administrator/VM user with vSphere Web Client are affected. To improve continuity of operations, setting the Recovery function of Windows services is recommended. Set the Recovery function for the following services of ETERNUS SF Manager and ETERNUS VASA Provider:

- ETERNUS SF Manager Tomcat Service
- ETERNUS SF Manager Apache Service
- AdvancedCopy Manager COM Service
- ETERNUS Information Provider

The procedure is as follows:

1. Click **Control Panel > System and Security > Administrative Tools > Services** to open the **Service** screen.
2. Open the **Properties** screen of Services.
3. Select the **Recover** tab and set each item as follows.

Item	Settings
First failure	"Restart the Service" or "Restart the Computer"
Second failure	"Restart the Service" or "Restart the Computer"
Subsequent failures	"Restart the Service" or "Restart the Computer"
Reset fail count after	1 day
Restart service after	1 minute

4. Check the **Enable actions for stops with errors** checkbox.
5. Click **Restart Computer Options...** and set the time of Restart computer after to one minute later. However, if "Restart the Computer" is not specified in step 3, this step is not required.

### Point

- When an error occurs, whether to restart the service or restart the computer can be changed according to the operation. However, for ETERNUS SF Manager Apache Service, be sure to set the computer to restart.
- The time of Reset fail count after, Restart service after, and Restart computer after can be changed according to the operation.

### Note

- For the following services of ETERNUS SF Manager, the recovery function of Windows services is not available.
  - ETERNUS SF Manager Postgres Service
  - ETERNUS SF Storage Cruiser Optimization Option

If something goes wrong with operation of Web Console, check whether these services are running.

- If the following message is displayed in the event log of Web Console, check whether every service of ETERNUS SF Manager is running.

```
escs11002 Applying the policy failed. policy=policy, target=target, detail=detail
```



- If any service of ETERNUS SF Manager and ETERNUS VASA Provider is not running, take one of the following actions manually to recover the service:
  - Restart the service.
  - Restart the operating system.
  - When the Management Server is created on the virtual machine and when a VM host is made redundant with vSphere HA, switch to the VM host you want to use and restart the operating system.

## 2.2.3 Configuration and Registration of Managed Devices

---

### ETERNUS Disk Storage System

#### Device Configuration/Registration

Configure and register all ETERNUS Disk storage systems on which Virtual Volumes are created.



See

Refer to "Disk Storage Systems and All-Flash Arrays" in "Environment Configuration" in the *Storage Cruiser Operation Guide* for configuration items and work procedures.

Refer to "Registering Device" in the *Storage Cruiser Operation Guide* for the registration procedure.

#### License Registration

In order to operate the VMware vSphere Virtual Volumes environment, it is necessary to register the licenses for all ETERNUS Disk storage systems on which Virtual Volumes are allocated. Refer to "[Table 1.1 Operating Environment](#)" in "[1.1 Operating Environment](#)" for license registration.



See

Refer to "Register License" in the *Web Console Guide* for the registration procedure.

### FC Switch

#### When FC Switches Which Support Level Is A or B

When managing access paths and VVOL access paths with this product, set up and register the FC switch.

When not registering the FC switch on this product, set up a network and zoning for the FC switch.



See

Refer to "Fibre Channel Switch" in "Environment Configuration" in the *Storage Cruiser Operation Guide* for configuration items and work procedures.

Refer to "Registering Device" in the *Storage Cruiser Operation Guide* for the registration procedure.

#### When FC Switches Other than That Above

Set up a network for the FC switch. Also, as required, set up zoning.

### VM Host

Configure and register all VM hosts that use the Virtual Volumes.



See

Refer to "VMware Server Node" in "Environment Configuration" in the *Storage Cruiser Operation Guide* for configuration items and work procedures.

Refer to "Registering Device" in the *Storage Cruiser Operation Guide* for the registration procedure.

### VMware vCenter Server

Register all VMware vCenter Servers that manage VM hosts that use Virtual Volumes.

Register users with administrator permissions on the VMware vCenter Server as users.



See

Refer to "Register/Reload VMware vCenter Server and Change User Information of VMware vCenter Server" in "Operations for VMware vCenter Server" in the *Web Console Guide* for the registration procedure.

## 2.2.4 Configuration of Advanced Copy Connection Type

When operating the virtual machine backup, set the Advanced Copy connection type.

When the connection type is already set, or when not using the virtual machine backup function, this is unnecessary.



See

Refer to "Configure Connection Type for ETERNUS Disk Storage System" in the *Web Console Guide* for configuration procedures.

When setting the connection type, select "Access from volume" or "Access from network".

## 2.2.5 Configuration of VVOL Access Path

Configure the VVOL access path (access path for Virtual Volume) between the VM host and ETERNUS Disk storage system.



See

Refer to "2.3.2 VVOL Access Path Management" for details on the VVOL access path.

Refer to "VVOL Access Path Setting" in the *Web Console Guide* for VVOL access path configuration procedures.

## 2.2.6 Creation of VVOL Datastore

Create a VVOL datastore on the ETERNUS Disk storage system. When using the virtual machine backup function to create a Clone backup, create a Clone backup VVOL datastore.

Creation of Tier Pool

Create a Tier pool. When using Automated Storage Tiering, create a Tiering policy before creating the Tier pool.



See

Refer to the *Storage Cruiser Operation Guide for Optimization Function* for details on Automated Storage Tiering. Refer to the following section in the *Web Console Guide* for procedures for Tiering policy creation and creation of Tier pools comprise the VVOL datastore/Clone backup VVOL datastore.

- "Create Tiering Policy"

- "Create Tier Pool for Configuring VVOL Datastore / Clone backup VVOL Datastore"

Creation of VVOL Datastore

Create a VVOL datastore by one Tier pool or combining two or more Tier pools.



Refer to "Create VVOL Datastore" in the *Web Console Guide* for VVOL datastore creation procedures.

Creation of Clone Backup VVOL Datastore

When creating a Clone backup using the virtual machine backup function, create a Clone backup VVOL datastore by one Tier pool or combining two or more Tier pools.



Refer to "Create Clone Backup VVOL Datastore" in the *Web Console Guide* for creation procedure of Clone backup VVOL datastore creation procedures.



Refer to "2.3.3 VVOL Datastore Management" for details on VVOL datastores.

## 2.3 Operation of Storage System

This describes the operation of the storage system in the VMware vSphere Virtual Volumes environment.

### 2.3.1 Resource Management

#### Virtual Volume Management

This product displays the information on Virtual Volumes created using a virtual machine on the VMware vCenter Server. A Virtual Volume is also an FTV. A Virtual Volume has "Block/VVOL" displayed under **Usage** column on the Web Console Volume List screen.

The Virtual Volume types are as follows. These types are displayed as **VVOL Type** column on the Web Console Volume List screen.

Table 2.8 Virtual Volume Type

VVOL Type	Meaning
Config	For VMware management information
Data	For OS and business data
Swap	For swap area
Memory	For memory image at time of Snapshot
Other	Other than the above



- For other volumes than Virtual Volume, the **VVOL Type** is displayed as a hyphen (-).

- If an error occurs while creating the virtual machine or operating the Snapshot, there are times when a mid-creation Virtual Volume remains. In this case, the **VVOL Type** is displayed as "Unknown".

---

## Configuration Information

### VVOL Metadata

Each Virtual Volume has configuration information which is called "VVOL Metadata". VVOL Metadata is stored in both the repository on this product and the ETERNUS Disk storage system. Even if the ETERNUS Disk storage system is deleted from this product, the VVOL Metadata information is not deleted from the repository for this product. If the ETERNUS Disk storage system is deleted from this product and will not be reused, execute the "esfadm esfdata delete" command to delete the VVOL Metadata information from this product.

### Repository

If the repository of this product gets corrupted or restored from backup, first restore the Storage Cruiser's manager environment. After that, execute the "esfadm esfdata restore" command to reflect the latest information stored in the ETERNUS Disk storage system to the repository of this product.

If the information stored in the ETERNUS Disk storage system is damaged, execute the "esfadm esfdata backup" command to reflect the repository information for this product in the ETERNUS Disk storage system.

## Note

- Virtual Volumes cannot be created/deleted on this product. However, the exception is a Virtual Volume whose **VVOL Type** is "Unknown", which can be deleted. If deleting a number of Virtual Volumes, multiple volumes cannot be deleted at the same time, so delete them one by one.
- Virtual Volume information cannot be displayed with the "storageadm" command.
- In the ETERNUS Disk storage system, the VVOL metadata is stored on the FTV named "\$VVOL\_META". This FTV cannot be deleted from this product. To remove the Tier pool in which this FTV exists, take the following steps:
  1. Execute FTV RAID Migration to other Tier pool on ETERNUS Web GUI.  
For RAID Migration, select "Thick" for Allocation settings on the migration destination volume.
  2. Delete the target Tier pool on Web Console.
- For Allocation settings of FTV whose name is "\$VVOL\_META", "Thick" is fixed and no change is required. When Allocation settings were changed to "Thin" on Web Console, perform the **Reload Conf.** operation to make the information on Web Console up-to-date.

## See

- Refer to "Restoring Manager" in the *Storage Cruiser Operation Guide* for the restore method of the Storage Cruiser's manager environment.
- Refer to "Command References" in the *Storage Cruiser Operation Guide* for information on the command.

---

## 2.3.2 VVOL Access Path Management

When using a Virtual Volume, set the VVOL access path (access path for Virtual Volume) between VM hosts and the ETERNUS Disk storage system.

Regardless of whether the access path is set or not, be sure to set the VVOL access path.

The VVOL access path operations are as follows:

- [Creation of VVOL Access Path](#)
- [Display of VVOL Access Path Usage State](#)
- [Inheritance of VVOL Access Path](#)

- [Deletion of VVOL Access Path](#)

### Note

Operate the VVOL access path from Web Console. The "storageadm" command cannot be used for operation.

### Point

- Advanced knowledge is required to use the VMware vSphere Virtual Volumes function with the ETERNUS Disk storage system in which the maximum pool capacity has been changed. For this reason, when using the VMware vSphere Virtual Volumes function, it is recommended that you operate the system without changing the configuration for the maximum pool capacity of the ETERNUS Disk storage system.  
If you use the VMware vSphere Virtual Volumes function with the ETERNUS Disk storage system in which the maximum pool capacity has been changed, enable the VMware vSphere Virtual Volumes function using ETERNUS CLI before creating a VVOL access path. Refer to the ETERNUS Disk storage system manual for information on the command names and syntax of ETERNUS CLI.
- The icons and meanings used for the access path are also used for the VVOL access path state. For icon states and their meanings, refer to "Access Path Status Display" in the *Storage Cruiser Operation Guide*.

## Creation of VVOL Access Path

Refer to "VVOL Access Path Setting" in the *Web Console Guide* for creation of a VVOL access path.

In the Fibre Channel environment, you can set the ETERNUS Disk storage system host affinity and FC switch zoning. In the iSCSI environment, you can set the ETERNUS Disk storage system host affinity.

### Point

- As the Virtual Volume does not use the affinity group, the affinity group does not need to be created in advance. The affinity group is required when setting the access path.
- When booting the VM host from a SAN or when allocating a volume that configures VMFS datastore, set both the access path and VVOL access path.
- In an environment where both the access path and VVOL access path are set, if only one of the access paths is deleted, FC switch zoning is not deleted.
- When setting multiple VVOL access paths between one VM host and one ETERNUS Disk storage system, they are set automatically as multipath.
- When a host group is used, a VVOL access path can be configured for the ports of an ETERNUS Disk storage system that are registered in the host group. However, the ports are removed from the host group for the ETERNUS Disk storage system that is connected to the VM host for which the access path is set.

## Display of VVOL Access Path Usage State

The statuses of VVOL access path are as follows. The status is displayed in the **VVOL Function** column on the Web Console Access Path List screen.

Table 2.9 VVOL Access Path Status List

Character String Displayed in <b>VVOL Function</b> column	Meaning
Enable(Used)	VVOL access path in use (path that the virtual machine is operating)
Enable(Unused)	VVOL access path not in use (path that the virtual machine is stopping)
Disable	Non VVOL access path

## Point

A Virtual Volume does not use an affinity group. For this reason, when only the VVOL access path is set, a hyphen (-) is displayed for the **Affinity Group** column on the Web Console Host Affinity List screen.

### Inheritance of VVOL Access Path

In the Fibre Channel environment, when exchanging the VM host HBA, access path inheritance work is necessary after replacement.

After replacing the HBA, perform work according to the HBA state after performing the **Reload Conf.** operation on the target VM host.

## Note

In the case of iSCSI environment, set the IP address and iSCSI name that were used prior to replacement in the HBA after replacement is completed. Access path inheritance work is not required.

If HBA Status Is "Changed"

With the access path inheritance work, both the access path and VVOL access path can be inherited.

## See

Refer to "Post-replaced HBA State Is "Changed"" in "Replacing Supported Device Components" in the *Storage Cruiser Operation Guide* for procedures.

If HBA Status Is not "Changed"

VVOL access path is inherited using the following procedure:

1. Delete the VVOL access path, referring to "Delete VVOL Access Path" in the *Web Console Guide*.
2. Change the access path if the access path is set, referring to "Post-replaced HBA State Is "Unknown"" in "Replacing Supported Device Components" in the *Storage Cruiser Operation Guide*.
3. Recreate the VVOL access path, referring to "VVOL Access Path Setting" in the *Web Console Guide*.

### Deletion of VVOL Access Path

Refer to "Delete VVOL Access Path" in the *Web Console Guide* for VVOL access path deletion procedures.

## Point

- In environments in which multipath is not configured, the VVOL access path in use (path that the virtual machine is operating) cannot be deleted.  
In environments in which multipath is configured, VVOL access paths can be deleted until there is only one VVOL access path remaining.
- In an environment in which both a access path and a VVOL access path are set, if only one of the access paths is deleted, FC switch zoning is not deleted. In both the access path and the VVOL access path are deleted, zoning is deleted.

## 2.3.3 VVOL Datastore Management

A VVOL datastore is a datastore on which Virtual Volumes are set. The VVOL datastore can be used after creating the VVOL datastore on this product and registering the VMware vCenter Server.

The Clone backup VVOL datastore is used for Clone backup via the virtual machine backup function. Use without registering on the VMware vCenter Server.

### Creation of Tier Pool

VVOL datastores and Clone backup VVOL datastores are configured of one Tier pool or combination of two or more Tier pools. For this reason, it is necessary to create the Tier pools beforehand. When using the Automated Storage Tiering function, create the Tiering policy prior to create the Tier pool.

Create the Tiering policy, referring to "Create Tiering Policy" in the *Web Console Guide*. Create the Tier pool, referring to "Create Tier Pool for Configuring VVOL Datastore / Clone backup VVOL Datastore" in the *Web Console Guide*.



- Refer to the *Storage Cruiser Operation Guide for Optimization Function* for details on Automated Storage Tiering and Tiering policy.
- Refer to "Automated Storage Tiering Management" in the *Storage Cruiser Operation Guide* and the *Storage Cruiser Operation Guide for Optimization Function* for details on creating Tier pools.

### Creation of VVOL Datastore/Clone Backup VVOL Datastore

#### Creation of VVOL Datastore

VVOL datastores are datastores for creating Virtual Volumes. If a VVOL datastore created on this product is registered on the VMware vCenter Server, it can be used as a datastore to locate a virtual machine configured of Virtual Volumes.

One Tier pool or combine two or more Tier pools to create a VVOL datastore, referring to "Create VVOL Datastore" in the *Web Console Guide*.

Create a VVOL datastore on all ETERNUS Disk storage systems that use Virtual Volumes. It is possible to create multiple VVOL datastores on one ETERNUS Disk storage system.



In the vSphere HA environment, registering datastores on the VMware vCenter Server creates Config type VVOL for the vSphere HA configuration information on a per datastore basis.



- A VVOL datastore comprised across multiple ETERNUS Disk storage systems cannot be created.
- Do not mix Tier pools with different chunk sizes within the same VVOL datastore.  
The chunk size set for the Tier pool is determined based on the maximum pool capacity of the ETERNUS Disk storage system. If you expand the maximum pool capacity after creating a Tier pool, Tier pools with a mix of different chunk sizes may exist within the ETERNUS Disk storage system.

#### Creation of Clone Backup VVOL Datastore

Clone backup VVOL datastores are datastores used for creating Clone backups with the virtual machine backup function (when "Enable" for **Clone Backup** is selected during policy design). Create one Clone backup VVOL datastore for each ETERNUS Disk storage system on which Clone backups are to be created.

Creation is not necessary when you are not intending to create Clone backups.

Create the Clone backup VVOL datastore by one Tier pool or combining two or more Tier pools, referring to "Create Clone backup VVOL Datastore" in the *Web Console Guide*.

## Point

- VVOL datastores and Clone backup VVOL datastores can be configured of a maximum of 16 Tier pools.
- Multiple VVOL datastores and Clone backup VVOL datastores can share the same Tier pools as desired. A maximum of 16 can be shared.
- Up to a total of 1023 VVOL datastores or Clone backup VVOL datastores can be created.
- A name of up to 16 characters can be applied to a VVOL datastore or Clone backup VVOL datastore. Characters that can be used in names are alphanumeric characters, sharps (#), hyphens (-), and underscores (\_). Names are not case-sensitive. Names starting with "POOLGROUP" cannot be configured.

### Display of VVOL Datastore Usage Status

The statuses of VVOL datastore and Clone backup VVOL datastore are as follows. The status is displayed in the **VVOL Function** column on the Web Console VVOL Datastore screen.

Table 2.10 VVOL Datastore Status List

Character String Displayed in <b>VVOL Function</b> column	Meaning
Enable(VVOL)	In use as VVOL datastore
Enable(CloneBackup)	In use as Clone backup VVOL datastore
Disable	Virtual Volumes uncreated VVOL datastore

## Point

VVOL datastores for which "Enable(VVOL)" is displayed cannot be deleted.

### Configuration Information

The configuration information for VVOL datastores or Clone backup VVOL datastores is saved in both the repository for this product and the ETERNUS Disk storage system. The configuration information is not deleted from the repository for this product, even if this product is deleted from the ETERNUS Disk storage system. In the case that the ETERNUS Disk storage system is deleted from this product and will not be reused, execute the "esfadm esfdata delete" command to delete the VVOL datastore configuration information from this product.

## See

Refer to "[Repository](#)" for the method of recovering the repository.

### Configuration Change of VVOL Datastore

The name and configuration of a created VVOL datastore and Clone backup VVOL datastore can be changed.

Change the configuration, referring to "Change VVOL Datastore" and "Change Clone backup VVOL Datastore" in the *Web Console Guide*.

## Point

- If VVOL datastore runs out of space, its space must be expanded.
  - When the operation of creating a Virtual Volume was performed  
Either expand the space of Tier pools constituting a VVOL datastore on which you want to create a Virtual Volume or add a new Tier pool to the VVOL datastore.



- When the operation was performed onto an existing Virtual Volume  
Expand the space of the Tier pool to which an operated Virtual Volume belongs.
- To a VVOL datastore and a Clone backup VVOL datastore, a maximum of 16 Tier pools can be added.

 **Note**

- When adding a Tier pool to a VVOL datastore or Clone backup VVOL datastore, specify a Tier pool existing in the same ETERNUS Disk storage system.
- Tier pools in the Virtual Volume cannot be deleted from the VVOL datastore.
- Tier pools with FTVs cannot be deleted from Clone backup VVOL datastore.
- Tier pools of which the VVOL datastore or Clone backup VVOL datastore are configured cannot be deleted.

**Deletion of VVOL Datastore**

VVOL datastores or Clone backup VVOL datastores that are no longer used can be deleted.

Refer to "Delete VVOL Datastore" and "Delete Clone backup VVOL Datastore" in the *Web Console Guide* for the deletion method.

 **Note**

- Before deleting a VVOL datastore from this product, unmount the VVOL datastore to be deleted from VMware vCenter Server.
- A VVOL datastore with a Virtual Volume cannot be deleted.
- A Clone backup VVOL datastore with an FTV cannot be deleted.

**2.3.4 Event Display**

When there is an error in the processing of this product by performing operations on the VMware vCenter Server or VM host, the error will be displayed in the event log on Web Console. If an error message is displayed, take appropriate action according to the error message, referring to the *Messages*.

 **Note**

Events, such as a Shell/Bat linkage or E-mail notification, cannot be linked.

**2.3.5 Performance Management**

This product supports Virtual Volume performance management.

With the performance management feature on this product, if you set the volume management range, volumes in this range are the subject of performance monitoring. Creating/deleting volumes from the VMware vCenter Server or VM host automatically increases or decreases the number of Virtual Volumes. By specifying "All" for the volume management range, increase or decrease in Virtual Volumes is automatically detected.

 **Note**

When there are a large number of volumes targeted for performance monitoring, a sufficiently long interval is required for performance monitoring. When specifying "All" for the monitoring volume, set "Minimum monitoring interval" to the minimum value and the monitoring interval is automatically adjusted according to the number of volumes.



See

Refer to "Performance Management" in the *Storage Cruiser Operation Guide* for details on performance management.

### 2.3.6 Correlation Management

With the End to End view feature of this product, a list of the related information from the VM host to storage is displayed. With the End to End view (VMware) feature, a list of the related information from the virtual machine to Virtual Volume is displayed.



Point

As a Virtual Volume does not use an affinity group, a hyphen (-) is displayed for the **Affinity Group** column on the Web Console Host Affinity List screen.



See

Refer to "End to End List Display" in "Operation" in the *Storage Cruiser Operation Guide* for details on End to End view.

### 2.3.7 Automated Storage Tiering

A Virtual Volume is also an FTV, and can use the Automated Storage Tiering function.

When creating the virtual machine, the various configurations for Automated Storage Tiering are set in accordance with the policy. Change the policy in order to change the configurations.

The configurations can be changed on this product as well. The policy properties that can be changed with this product are as follows.

Property
Priority FTSP
Low Quota Share (%)
Middle Quota Share (%)
High Quota Share (%)



Point

If the configurations are changed with this product, the Compliance Status may be displayed as "Noncompliant". If Compliance Status is displayed as "Noncompliant", execute "[Change of Policy](#)" and set the content changed with this product.



See

- Refer to the *Storage Cruiser Operation Guide for Optimization Function* for details on Automated Storage Tiering.
- Refer to "Automated Storage Tiering Management" in the *Storage Cruiser Operation Guide* for operation on one Tier.

## 2.3.8 Automated QoS

---

A Virtual Volume is also an FTV, and can use the Automated QoS function.

When creating a virtual machine, various configurations for the Automated QoS function are set according to the policy. Change the policy in order to change the configurations.

The configurations can be changed on this product as well. The policy properties that can be changed with this product are as follows.

Property
Automated QoS Enable/Disable

### Point

.....

If the configurations are changed with this product, the Compliance Status may be displayed as "Noncompliant". If you specify "Any" for **Automated QoS Enable/Disable** to change the policy, the Compliance Status becomes "Compliant".

.....

### See

.....

Refer to the *Storage Cruiser Operation Guide for Optimization Function* for details on Automated QoS.

.....

## 2.3.9 Cache Management

---

When creating a virtual machine, configurations for the Cache function are set according to the policy. Change the policy in order to change the configurations.

The configurations can be changed on this product as well. The policy properties that can be changed with this product are as follows.

Property
Extreme Cache

### Point

.....

If the configurations are changed with this product, the Compliance Status may be displayed as "Noncompliant". If you specify "Any" for **Extreme Cache** to change the policy, the Compliance Status becomes "Compliant".

.....

### See

.....

Refer to "Extreme Cache Management" in the *Storage Cruiser Operation Guide* for details on Extreme Cache.

.....

## 2.4 Backup Operation of Virtual Machine

---

This section describes the virtual machine backup operation carried out by the storage administrator.

Table 2.11 Each Work Item and Reference

Operation Phase	Item	Reference
Backup	Creating a Backup	"2.4.1 Backup"
	Operating Backup history	"2.4.3 Reference/Deletion of Backup History"

Operation Phase	Item	Reference
Restoration	Restoring from Snapshot	"Restoration from Snapshot Backup" in "2.4.2 Restoration"
	Restoring from Clone	"Restoration from Clone Backup" in "2.4.2 Restoration"
	Single item restore	"Single Item Restore" in "2.4.2 Restoration"
Operation change	Policy update	"2.4.4 Change of Backup Policy"
	Changing operation settings and operation environment	"2.4.5 Configuration Change of Backup Environment"

## 2.4.1 Backup

Back up the virtual machine, in accordance with the backup policy set for the virtual machine.

The backup can be automatically executed by setting the schedule in the policy settings. It is also possible to execute backup manually from Web Console.

In virtual machine backup, Snapshot of the virtual machine (called "Snapshot backup") and Clone backup are created via VMware. The created Snapshot backup and Clone backup are managed as history.

Whether to create Snapshot backup and Clone backup can be set in the backup policy. Refer to the following table for their settings.

Table 2.12 Policy Settings to Create Backup

Backup Type	Property Settings
Snapshot backup	Set <b>Number of Snapshot Generations</b> to "1" or more.
Clone backup	Set <b>Clone Backup</b> to "Enable".

### Point

- When creating a Snapshot from the vSphere Web Client, a Clone backup is not created. Further, Snapshot backup history is not created on the ETERNUS SF system.
- Virtual Volumes for Snapshot backup are created within the same VVOL datastore as the target Virtual Volume for Snapshot backup. Volumes for Clone backup are created within the Clone backup VVOL datastore.
- The execution status of physical copy of Clone backup can be checked on Web Console. Clicking the copy group name field in the **Clone Backup History** tab on the VVOL Backup History screen displays a list of copy group names used for the Clone backup in a dialog box. Clicking the link of the target copy group name in the dialog box moves to the Copy Group Detail screen, and the execution status of physical copy can be checked.
- When executing virtual machine backup, set the backup policy so that either of Snapshot backup or Clone backup or both of them are created. If it is set so that neither is created, **Operation Mode** of the backup policy is automatically set to "Disable".

### Note

Both Snapshot backups and Clone backups are created by using the Snapshot function of VMware. Therefore, the backup target virtual machine must have an environment that can perform the Snapshot function of VMware. Refer to the VMware manuals for the required conditions of VMware's Snapshot function.

Figure 2.3 Virtual Machine Backup Processing

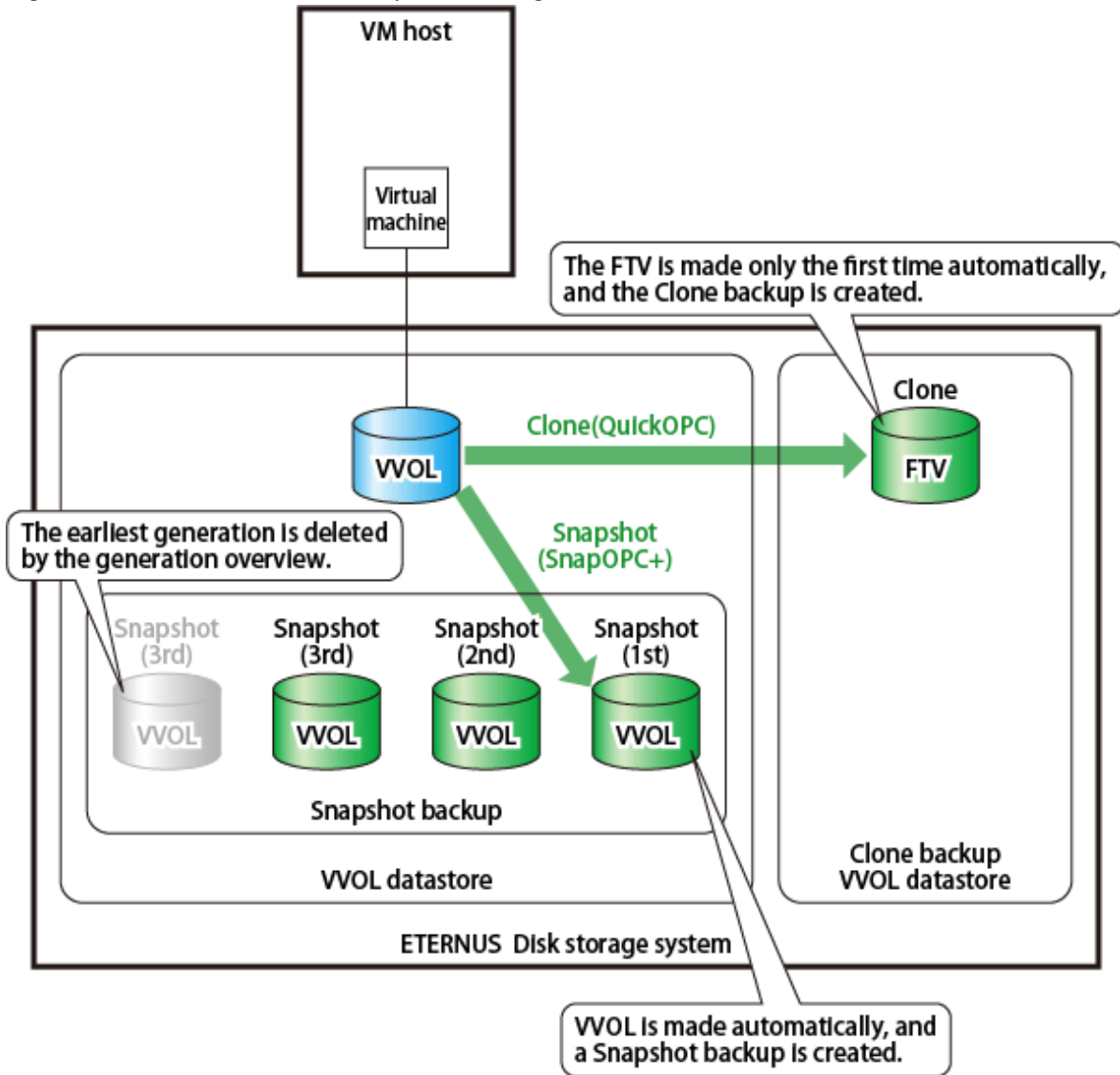

### Save Generations and Backup History

The Snapshot backup is generation-managed, in accordance with the number of save generations set in the backup policy. The overflow generation history and Snapshot backup are automatically deleted after backup processing is completed.

Clone backup is normally one generation (latest generation) operation. For this reason, the backup is overwritten and updated, and if an error occurs during processing, backup history is not retained.

The Snapshot backup and Clone backup operations are as follows.

Figure 2.4 Backup History Management Mechanism

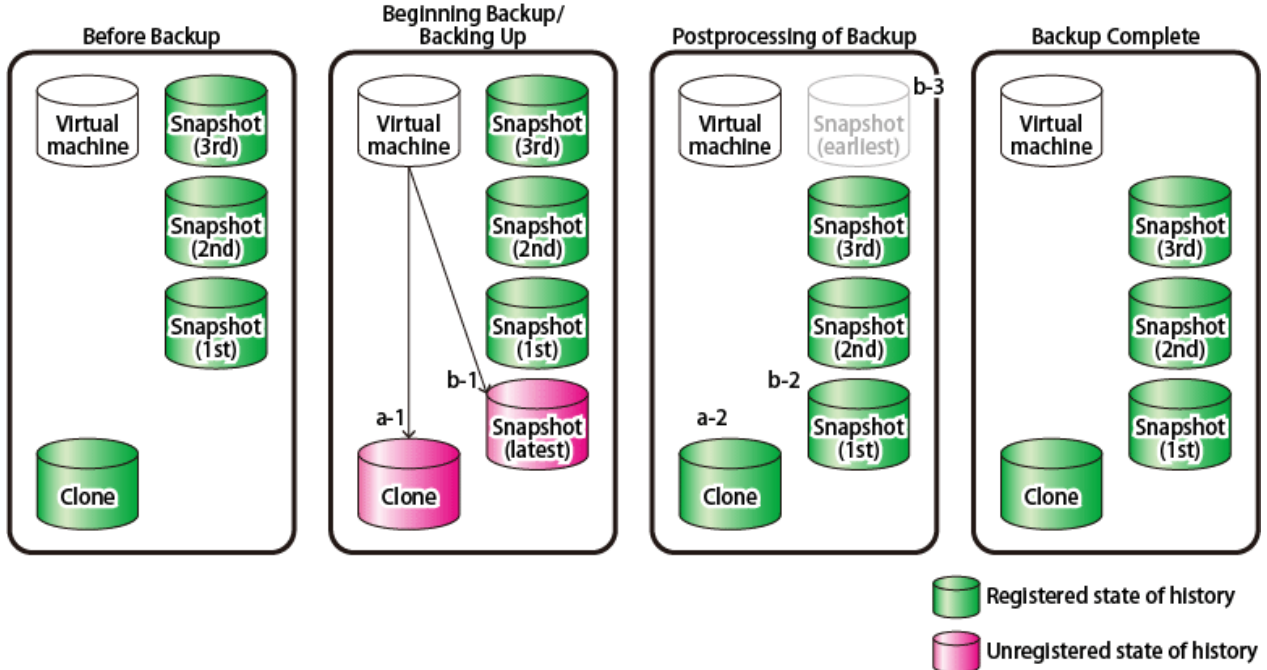

a. Clone backup

1. Delete the history and overwrite and update the existing Clone backup
2. Register the history

b. Snapshot backup

1. Create the most recent generation Snapshot backup (Virtual Volumes are automatically generated)
2. Register the most-recent generation history
3. Delete the oldest (overflow) generation Snapshot backup

**P** Point

When Clone backup is created by specifying "0" for **Number of Snapshot Generations**, Snapshot backup is not created. If the Allocation setting of the backup source Virtual Volume is "Thick", the VVOL datastore temporarily requires free space greater than or equal to the backup source Virtual Volume.

**N** Note

- If the Clone backup is not created normally due to errors occurring during processing, the Clone backup history does not exist, or the history backup date is blank and cannot be restored. In order to restore, we recommend removing the cause of the error immediately and re-executing the backup to create a Clone backup.
- If either the Snapshot backup or Clone backup fails, both the Snapshot backup and Clone backup fail.
- Virtual disks that are not targeted for backup are not backed up. Refer to "[Virtual Machine \(Connecting Disk Configuration\)](#)" in "[2.1.2.1 Virtual Machine Backup](#)" for details. If any virtual disk that is not targeted for backup is connected to the virtual machine, the following message is output in the processing result. As required, check disks that are connected to the virtual machine.

Warning : Unsupported backup volume was not backedup.

## Snapshot Name

The following names are automatically assigned to Snapshot backups created from the ETERNUS SF system. Both automatic execution and manual execution result in the same names.

```
ESF_YYYYMMDD_hhmm
```

"YYYYMMDD\_hhmm" is the backup start date and time. YYYY : year, MM : month, DD : date, hh : hours, mm : minutes.



### Example

If the Snapshot is started on January 18th, 2015 at 4:30, the Snapshot name is as follows:

```
ESF_20150118_0430
```

## Operations from VMware vCenter Server on Snapshot Backup Created on ETERNUS SF System

Snapshot backups created on the ETERNUS SF system (automatic execution on the ETERNUS SF system or manual execution from Web Console) can be operated from the VMware vCenter Server (vSphere Web Client). Refer to "3.5 Snapshot" for details.

- The "Name" of the Snapshot displayed on the VMware vCenter Server is set to the name automatically created by the ETERNUS SF system.
- The "Explanation" of the Snapshot displayed on the VMware vCenter Server is automatically set to the character string "Created\_by\_ESF". Both automatic execution and manual execution set the same character string for "Explanation".



### Note

- Do not delete the Snapshot created in the ETERNUS SF system from the VMware vCenter Server. When the Snapshot backup is deleted from vSphere Web Client, the Snapshot backup history managed by the ETERNUS SF System is not deleted, so delete the Snapshot using "Deletion of Snapshot Backup" from the ETERNUS SF system.
- When changing the Snapshot name from the vSphere Web Client, the displayed name is not reflected on the ETERNUS SF system. The name on the ETERNUS SF system is the same as that when automatically generated.

## Data Integrity

It is recommended that backup is performed while the virtual machine is stopped in order to perform a backup with maximum data integrity. If the virtual machine to be backed up cannot be stopped before the backup starts, stop the business applications running on the virtual machine to stop all I/Os. Enabling the Quiesce guest file system option in the policy is also recommended.

### 2.4.1.1 Auto Execution (Auto Backup)

Backup is automatically executed in accordance with the Backup policy set on the virtual machine.

In the backup policy settings, when **Operation Mode** is specified as "Auto", the scheduler task is registered in the scheduler for this product and automatically executed according to the specified cycle.



### Point

- Automatically executed scheduler tasks are registered according to the following settings:

Item	Configuration Value
Task Name	VM_Backup_YYYYMMDDhhmmssSSS (*1)

Item	Configuration Value
Type	VM Backup

\*1: "YYYYMMDDhhmmssSSS" is the date and time at which the scheduler task was registered. YYYY : year, MM : month, DD : date, hh : hours, mm : minutes, ss : seconds, SSS : milliseconds.

- The operations that can be performed for automatically executed scheduler tasks are described in the following sections in the *Web Console Guide*:
  - Execute Scheduler Task Immediately
  - Enable/Disable Scheduler Task

.....

You can temporarily stop automatic execution without changing the schedule settings. This is used when you want to temporarily stop automatic backup operation, such as when performing virtual machine or host maintenance.

Refer to "Automatic Execution Setting of Virtual Machine Backup" in the *Web Console Guide* for the operation method with Web Console.

### 2.4.1.2 Manual Execution

Execute the backup manually from Web Console. This function is used when tests before operation or urgent backups are required.

You cannot use this function for a virtual machine on which the **Operation Mode** in the Backup policy is set to "Disable".



See

.....

Refer to "Manual Execution of Virtual Machine Backup" in the *Web Console Guide* for the operation method with Web Console.

.....

### 2.4.1.3 Auto Execution with External Scheduler

This product offers a sample script for virtual machine backups.

Using an external scheduler in an existing operation environment can back up virtual machines. Centralized management of virtual machine backups using the external scheduler makes it easy to stop applications and cooperate with other jobs such as secondary backups.

A sample script is executed on the Management Server in a Windows environment.

Install and configure the sample script according to the instruction listed in this manual.



Note

- When executing a virtual machine backup from an external scheduler, set **Operation Mode** in the backup policy to "Manual" to avoid conflicts with the Auto Execution of backups by the ETERNUS SF system. Refer to "[3.3.1.1 Virtual Machine Backup](#)" for details about **Operation Mode**.
  - When, for example, manually executing a backup, restoring, or deleting the backup history, stop the backup schedule of the external scheduler in advance.
- .....

### Prior Settings

- Setting the PowerShell script execution policy

In accordance with the method listed at the following URL, set the execution policy of the script to "RemoteSigned" or "Unrestricted" on the Management Server.

<https://technet.microsoft.com/en-us//library/ee176961.aspx>



- Setting the environment variable PATH

Add the path of the program directory where ETERNUS SF Manager was installed to the environment variable PATH on the Management Server.

1. Right-click on **Computer** on the **Start** menu, and select the **Properties** from the pop-up menu.
2. Click **Advanced system settings** on the left side of **System** dialog box.
3. Click **Advanced** tab in the **System Properties** dialog box, and then click **Environment Variables**.
4. Add the following value to the environment variable PATH.

```
$INS_DIR\Common\bin
```

(\$INS\_DIR means "Program Directory" specified at the ETERNUS SF Manager installation.)

**Point**

When listing multiple path names, separate them with semicolons (;).

**Processing Details about Sample Script**

The sample script executes a backup and waits for the physical copy of Clone backup to finish.

Figure 2.5 Automation Procedure of Virtual Machine Backup Sample Script

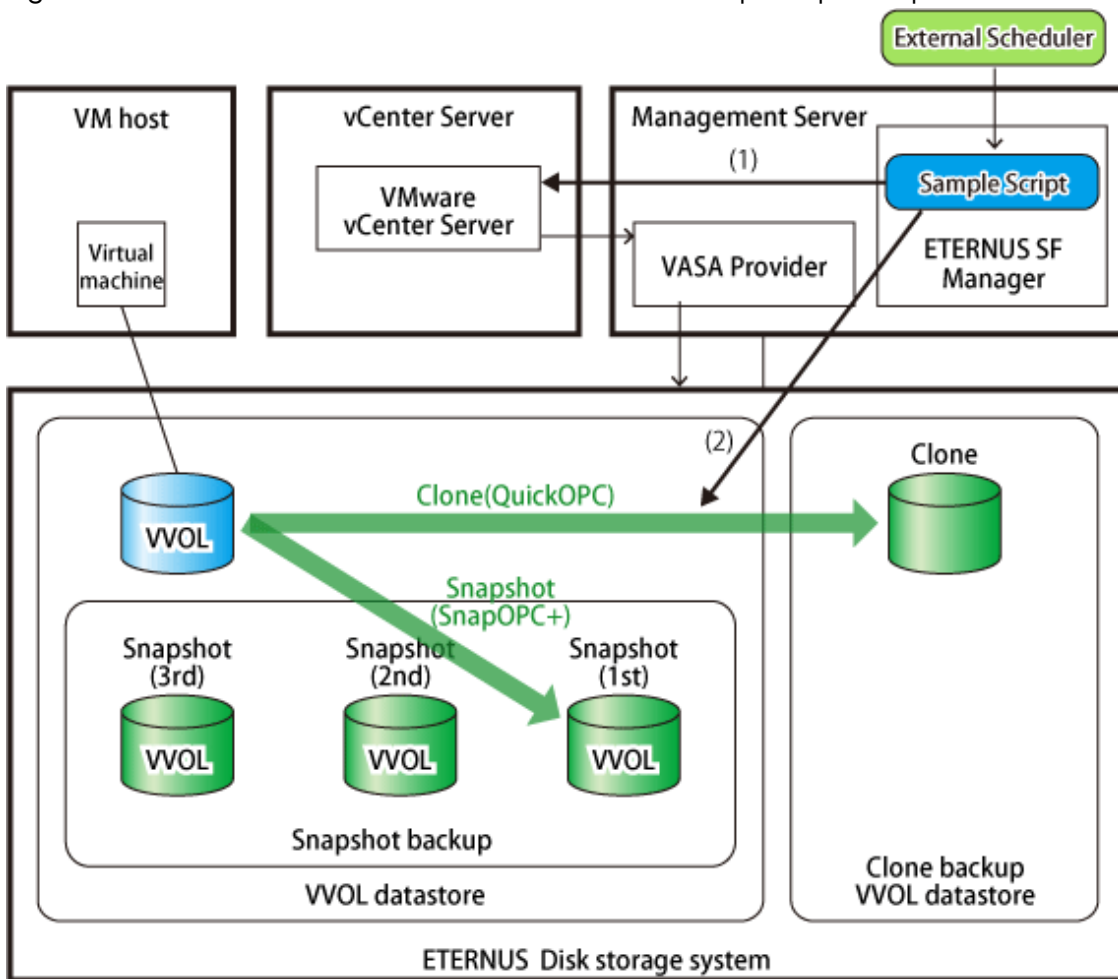

(1) The virtual machine is backed up by executing the "esfadm wvolvm backup" command. If another operation is being performed for the backup target virtual machine, the backup is performed after waiting for the other process to finish.

(2) Waits for the physical copy of Clone backup to finish by executing the physical copy wait script (wait\_qopc\_completion.ps1).

 **Information**

- In step (2), the sample script waits for the physical copy to finish only when "Enable" is set to **Clone Backup** in the backup policy.
- If processing step (2) is not required, comment out the call of wait\_qopc\_completion.ps1 in the script.
- The script must be executed by users with OS administrator privileges.

**Sample Script Stored Directory**

The sample script is stored in the following directory.

- \$INS\_DIR\Common\sample\vvolvms (\$INS\_DIR means "Program Directory" specified at the ETERNUS SF Manager installation.)

Copy the sample script from the above directory to a different directory and use the copied script. In addition, after customizing the copied file according to the actual backup operation, use that file.

**Interface for Sample Script**

SCRIPT NAME

vvolvms\_backup.bat

SYNOPSIS

vvolvms\_backup.bat *vmid*

OPERANDS

*vmid*

Virtual machine VMID of the backup target

 **Information**

Virtual machine VMID can be confirmed with the "[esfadm vvolvms info](#)" command.

EXIT STATUS

=0: Completed successfully

>0: Terminated abnormally

Exit Status	Description
1	Parameter error
2	Virtual machine backup error
3	Error in waiting for physical copy to finish

EXAMPLES

- When this script is executed and terminated normally

```
> vvolvms_backup.bat xxxxxxxx-xxxx-xxxx-xxxx-xxxxxxxxxxxxx
vvolvms_backup start.
vvolvms_backup end. rc=0
>
```

- When this script is executed and an error occurs in virtual machine backup

```
> vvolvm_backup.bat xxxxxxxx-xxxx-xxxx-xxxx-xxxxxxxxxxxxx
vvolvm_backup start.
vvolvm_backup is failed.
vmlinkxxxxx (error message).
vvolvm_backup end. rc=2
>
```

## 2.4.2 Restoration

The method of restoring are as follows.

Restore Types	Type of Backup	Explanation
Virtual machine restoration	Snapshot backup	Snapshot restore (recovery from point of capturing Snapshot) is performed on the virtual machine for which Snapshot backup was created.
Single item restore		This is a self-service type file unit restore that uses temporary volumes to restore only the files that require restoration, in file units from the Snapshot. A temporary volume is automatically created, to which to copy Snapshot backup. The temporary volume is automatically connected to the virtual machine for which the Snapshot backup is created. You can then refer to the newly-connected volume and restore the files manually.
Restoring to the new virtual machine	Clone backup	This creates a new virtual machine according to the virtual machine configuration at backup and performs the restore to the virtual machine.

### Restoration from Snapshot Backup

Restore from the created Snapshot backup.

This function is used for recovery from logical data defects. This cannot be used when the Snapshot backup source Virtual Volume is damaged or deleted.

Restore from Snapshot backup can be executed only when the **Number of Snapshot Generations** is set to "1" or more in the virtual machine backup policy.

Select the history of the Snapshot backup to recover, and execute the restore. An example of restoring from a Snapshot (2nd generation) is shown in the following diagram.

Figure 2.6 Restoration from Snapshot Backup

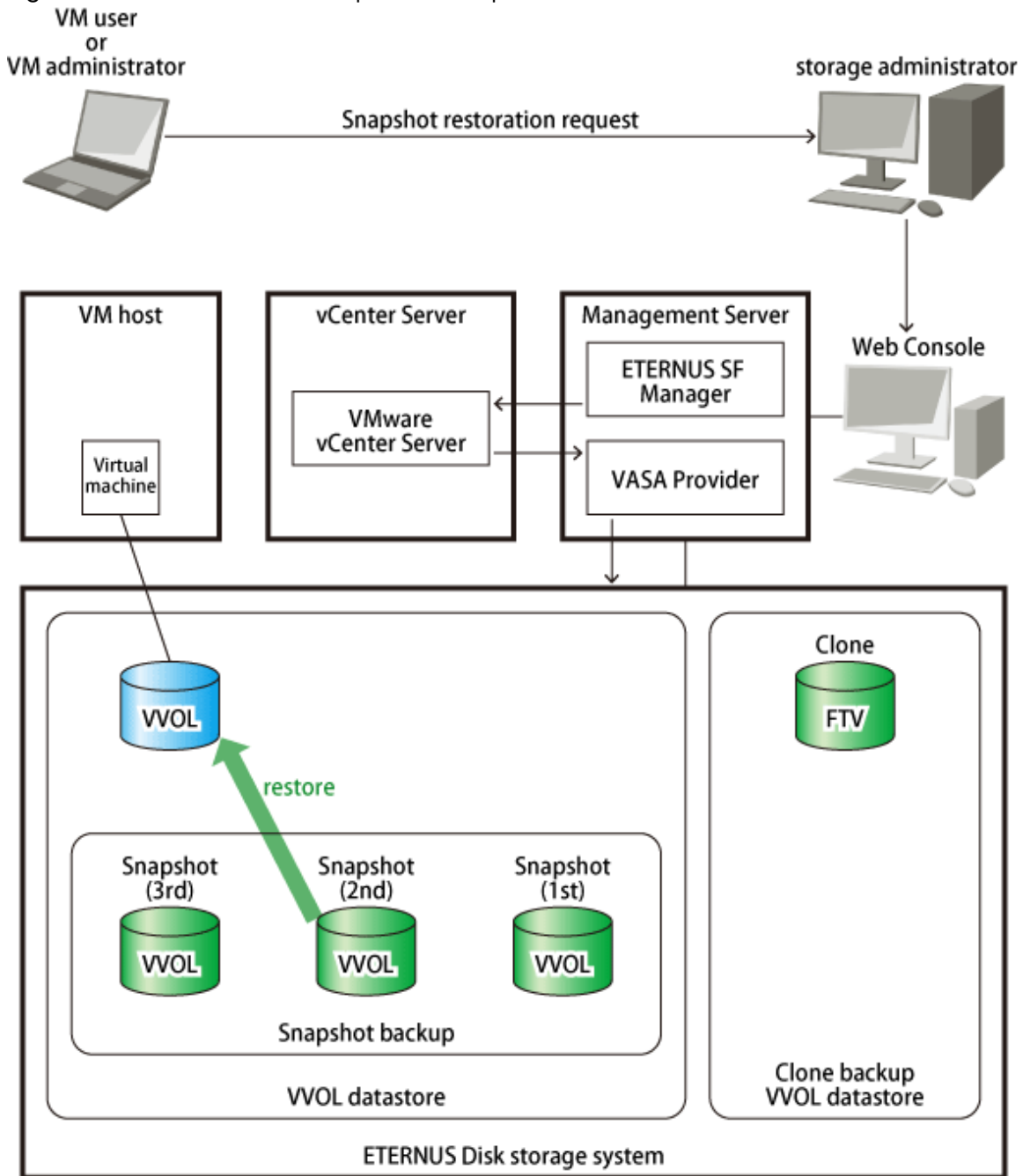

 See

Refer to "Restore from Snapshot Backup" in the *Web Console Guide* for the operation method of restoration from Snapshot backup with Web Console.

### Restoration from Clone Backup

If restore from a Snapshot cannot be performed due to physical defects, etc., restore using Clone backup. Restore from Clone backup can be executed only when **Clone Backup** in the virtual machine backup policy is set to "Enable".

Figure 2.7 Restoration from Clone Backup

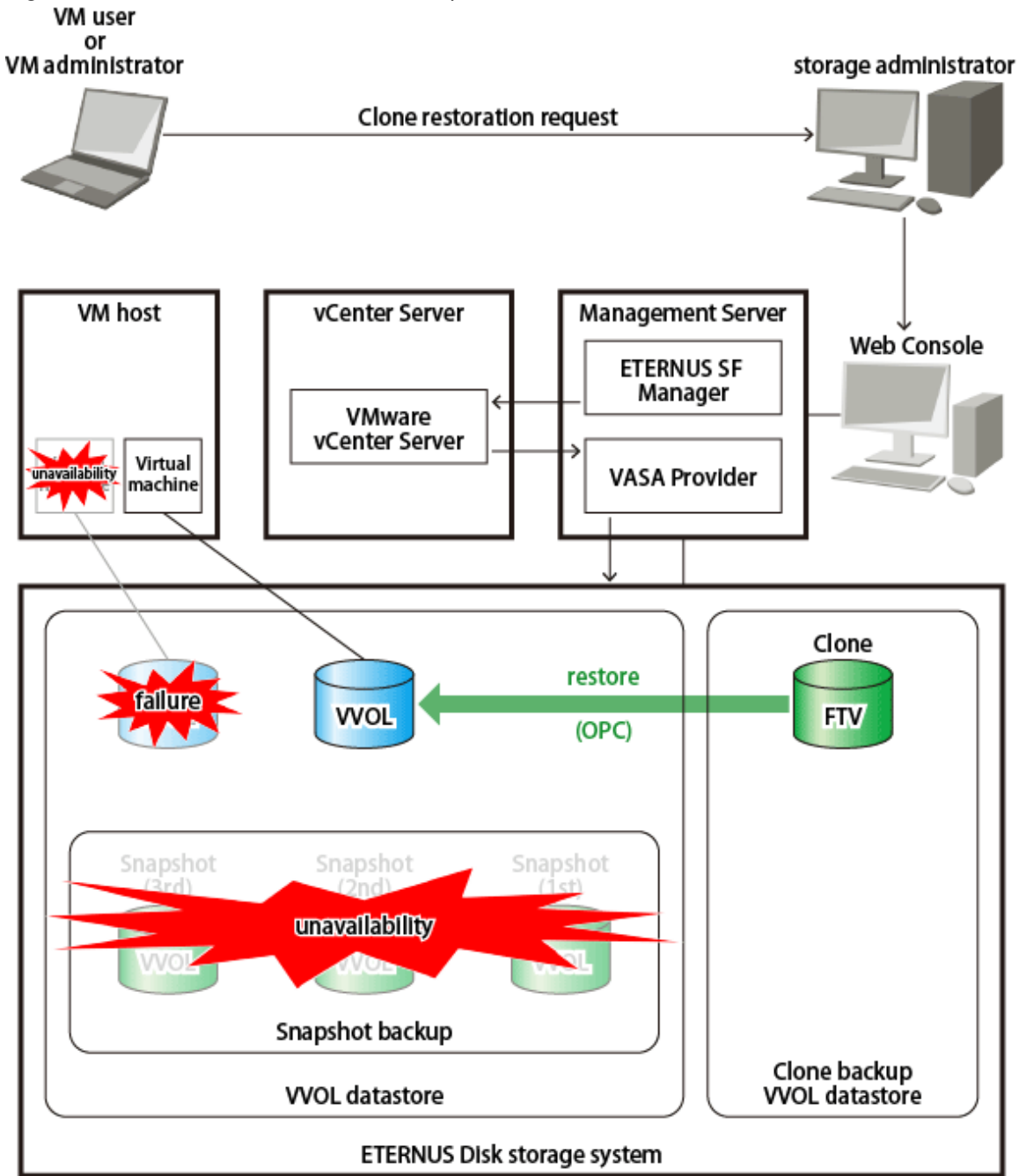

When restoring from Clone backup, a new virtual machine is created based on the virtual machine definition at the time of Clone backup, and this data is used for recovery. The new virtual machine is created on VM hosts (VMware ESXi) belonging to the backup source at the time of Clone backup.

**P Point**

When restoring from Clone backup, as a virtual machine is newly created and restored, it is possible to restore in a state where a backup source virtual machine does not exist.

The restore destination is the same VVOL datastore as the backup source. For this reason, if there is no space on the restore destination VVOL datastore, restore cannot be performed. Check the volume again, and add disks and Tier pools as necessary.

## Note

- When a virtual machine with the same name as the new virtual machine exists on the VMware vCenter Server, it is necessary to change the virtual machine name of the new virtual machine.
- A virtual machine will be newly created, thus when a virtual machine cannot be newly created on the restored virtual machine host (VMware ESXi) or VMware vCenter Server (when the number of virtual machines have reached the upper limit, etc.), restore cannot be carried out.
- The following information is not restored:
  - Virtual machine Snapshot
  - VM Storage Policies (Default policy of the restore destination VVOL datastore is used.)
  - Virtual machine BIOS settings (Default settings are used.)
  - Virtual machine MAC address (A new MAC address is allocated.)
  - Virtual disks not targeted for backup/restoration  
Refer to "[Virtual Machine \(Connecting Disk Configuration\)](#)" in "[2.1.2.1 Virtual Machine Backup](#)" for details.  
If any virtual disk that is not targeted for backup/restore exists, the virtual disk information is output in the **Detail** field of **Operation Detail** in **Operation History** in the following format. If it is output, reconnect the virtual disk from VMware vCenter Server as required.

```
Unsupported Restore Volume=[Disk File : vmdkFileName, XXXXX]
```

The following is an output example.

```
Unsupported Restore Volume=[Disk File : [datastore1] VM001_K0170/VM001_K0170.vmdk, Virtual  
flash read cache : (0MB,0KB), Virtual Device Node : SCSI(0:1), Disk Mode : persistent]
```

## Point

- The virtual machine newly created through the restore is automatically registered on the ETERNUS SF system by turning on the power to the virtual machine.
- The policy of the virtual machine or Virtual Volume newly created through the restore is the default (restore destination VVOL datastore default policy).  
Additionally, the status of the virtual machine is one in which the history (Snapshot backup, Clone backup) does not exist. After the policy has been set according to the operation, perform the virtual machine backup. Refer to the following when setting or changing policies:
  - All VM Storage Policies: "[2.1.2 Policy Design](#)" and "[3.3.2 Change of Policy](#)"
  - Backup policies: "[2.4.4 Change of Backup Policy](#)"

Restore from Clone backup uses the ETERNUS Disk storage system OPC function.

## Note

The virtual machine can be accessed immediately after OPC logical copy is complete, but while the physical copy operating in the background is incomplete, the following operations cannot be executed:

- Operation using vSphere Web Client  
Creating Snapshots, creating Clones, and Storage vMotion
- Operation using Web Console  
Backup and restoration

## Point

---

The execution status of physical copy of the OPC on the ETERNUS Disk storage system can be checked on Web Console.

Clicking the copy group name field in the **Clone Backup History** tab on the VVOL Backup History screen displays a list of copy group names used for the Clone backup in a dialog box. Clicking the link of the target copy group name in the dialog box moves to the Copy Group Detail screen, and the execution status of physical copy can be checked.

---

## See

---

Refer to "Restore from Clone Backup" in the *Web Console Guide* for the operation method of restoration from Clone backup with Web Console.

---

## Single Item Restore

Restore in file units from the Snapshot backup.

Single item restore can be executed only when the **Number of Snapshot Generations** is set to "1" or more in the virtual machine backup policy.

When the VMDK file is selected from Snapshot backup history and Single item restore is executed, the Virtual Volume within the Snapshot backup is copied to the temporary volume, and the temporary volume is automatically connected to the virtual machine. After this is complete, mount the volume manually and restore the desired files using Explorer.

An example of Single item restore from a Snapshot (2nd generation) is shown in the following diagram.

Figure 2.8 Single Item Restore

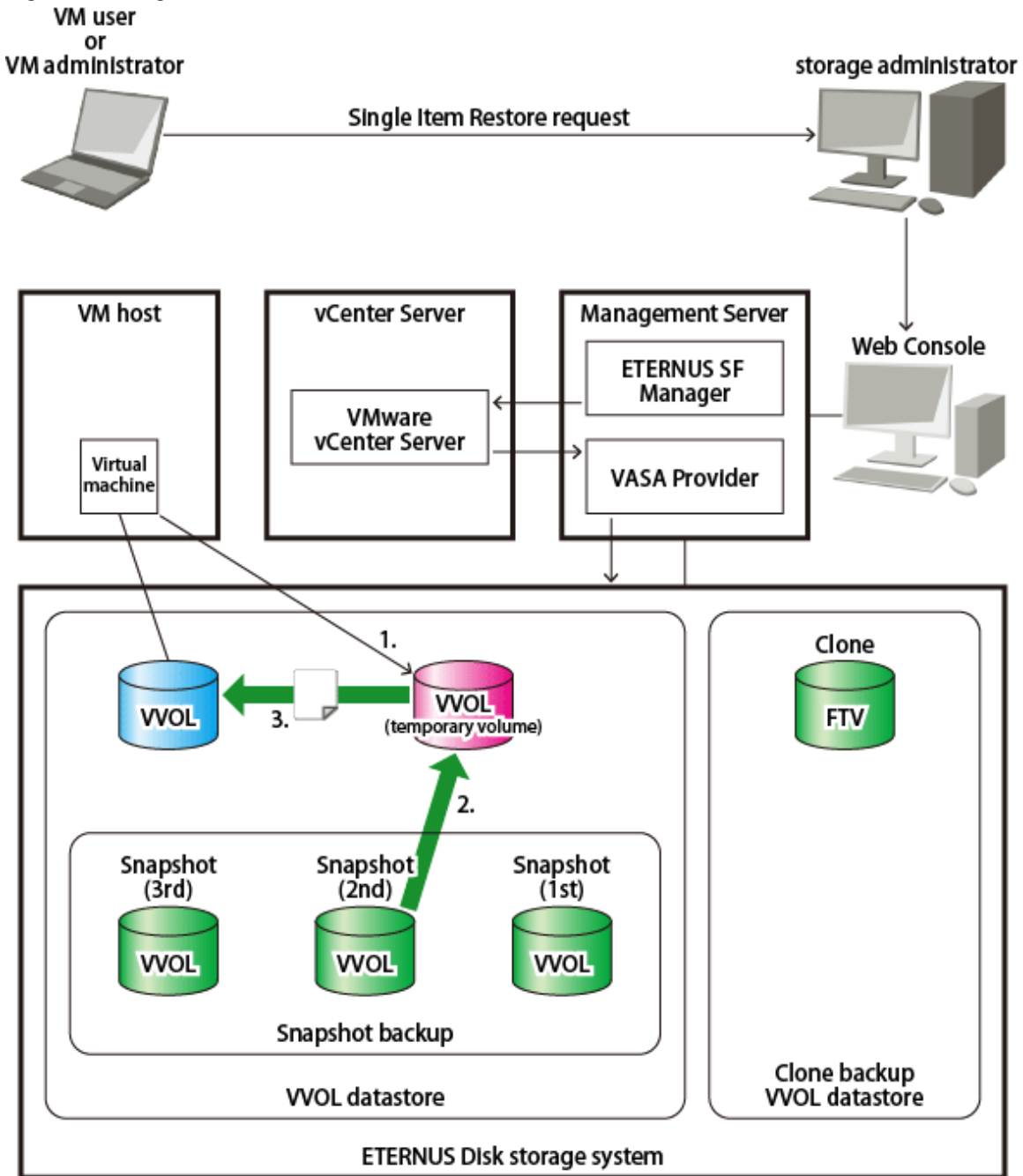

1. Create the temporary volume and connect to the virtual machine (executed by ETERNUS SF system)
2. Copy the Virtual Volume within the Snapshot backup to the temporary volume (SnapOPC+) (executed by ETERNUS SF system)
3. Restore the file (executed by user)

Regarding Temporary Volume for Single Item Restore Connected to Virtual Machine

After executing Single item restore processing, the following scheduler task is registered in the scheduler of this product, and after the specified time has passed, the temporary volume is automatically deleted.



Table 2.13 Scheduler Task

Item	Configuration Value
Task Name	VM File Restore Finish_YYYYMMDDhhmmssSSS (*1)
Type	VM File Restore Finish

\*1: "YYYYMMDDhhmmssSSS" is the date and time at which the Single item restore was started. YYYY : year, MM : month, DD : date, hh : hours, mm : minutes, ss : seconds, SSS : milliseconds.

The time until the volume is automatically deleted can be set as required (1 - 99 hours). Alternately, it can be instantly deleted at the point that restore is complete. When deleting immediately, execute the above scheduler task immediately.

 **Point**

The following operations are possible for the registered scheduler task:

- Immediate execution
- Stop (disable)
- Start (enable)
- Deletion

 **See**

Refer to "Operations Started From Scheduler Tab" in the *Web Console Guide* for the operation method of schedule tasks with Web Console.

A temporary volume connected to a virtual machine is created as the following attributes in the same VVOL datastore as Snapshot targeted for restore.

Attribute (*1)	Content
Disk Provisioning	Thin Provisioning
Virtual Device Node	SCSI
Disk Mode	Independent-type
VMDK File Name	ESF_TEMP_sourceVmdkFileName
Connection Destination	Located in order from controller 0(SCSI 0:x)

\*1: The term of each item may vary with the version level of vCenter Server.

 **Note**

- If there is no space in the SCSI controller in which to add the temporary volume on the connected virtual machine, the temporary volume creation/connection processing fails (SCSI controller is not automatically added).  
Add a SCSI controller or prepare a free controller from within the existing controllers and re-execute.
- Do not migrate a virtual machine (Storage vMotion) with the temporary volume connected to the virtual machine. The temporary volume may not automatically be removed. In that case, remove the temporary volume manually.
- Do not execute Snapshot backup while a temporary volume exists. The temporary volume could not be removed. When automatic backup is in progress, suspend the automatic backup and then execute Single item

restore. To suspend automatic backup, refer to "Automatic Execution Setting of Virtual Machine Backup" in the *Web Console Guide* to disable automatic execution of virtual machine backup.

- Multiple Single item restores cannot be executed simultaneously (consecutively) for one virtual machine. When executing consecutively, perform restoration after removing the previously-created temporary volume.
- Single item restore from a Snapshot of backed up Windows dynamic disks is unsupported.



See

Refer to "Single Item Restore from Snapshot Backup" in the *Web Console Guide* for the operation method for Single item restore with Web Console.

## 2.4.3 Reference/Deletion of Backup History

---

### Snapshot Backup History

Refer to Snapshot Backup History

Refer to the captured Snapshot backup history. The Snapshot that is captured on vSphere Web Client is not displayed.



See

Refer to "Display Virtual Machine Backup History" in the *Web Console Guide* for the operation method with Web Console.

Deletion of Snapshot Backup

Delete the captured Snapshot backup history and the Snapshot backup.

In order to delete the Snapshot backup, the deleted Snapshot cannot be operated even in vSphere Web Client.



See

Refer to "Delete Snapshot backup" in the *Web Console Guide* for the operation method with Web Console.

### Clone Backup History Information

Clone Backup History Reference

Refer to the history of the captured Clone backup.

Even if the virtual machine is deleted from the ETERNUS SF system, the Clone backup history is not deleted. For this reason, you can refer to the Clone backup history for the deleted virtual machine.



See

Refer to "Display Virtual Machine Backup History" in the *Web Console Guide* for the operation method with Web Console.

## Note

When there is history without the backup date and time, the Clone backup has not been captured correctly due to an error, so restore cannot be performed. Re-execute backup to capture a Clone backup, or where Clone backup is not necessary, delete the history.

### Deletion of Clone Backup

Delete the captured Clone backup history and Clone backup.

## See

Refer to "Delete Clone Backup" in the *Web Console Guide* for the operation method with Web Console.

## 2.4.4 Change of Backup Policy

---

Change policies from vSphere Web Client.

## See

Refer to "3.3.2 Change of Policy" for details about changing policies.

## 2.4.5 Configuration Change of Backup Environment

---

### Configuration Changes of Clone Backup VVOL Datastore

Change (add/delete Tier pools) and delete the configuration of the Clone backup VVOL datastore.

Refer to "[Configuration Change of VVOL Datastore](#)" and "[Deletion of VVOL Datastore](#)" for how to change (add/delete Tier pools) or delete the configuration for the Clone backup VVOL datastore.

## 2.4.6 Secondary Backup of Clone backup and Data Use on Other Storage Devices

---

Data in the system area and data area can be secondarily backed up separately from Clone backup.

Perform secondary backup not on a per virtual machine basis but on a per volume basis that comprises a virtual machine. Restore data also not on a per virtual machine basis but on a per volume basis.

## Note

- The restore function from Clone backup cannot restore the virtual machine using secondary backup. When using secondary backup data, connect the secondary backup volume to either of the following virtual machines to use:
  - Virtual machine created manually
  - Existing virtual machine
- If the virtual machine environment is changed, the Clone backup volume is deleted and a new Clone backup volume is assigned when a Clone backup is performed for the first time after the change. Therefore, disable the secondary backup setting before changing the virtual machine environment. Enable the secondary backup setting again to the newly created Clone backup volume. Changes in the virtual machine environment are as follows:
  - Deleting volumes connected to the virtual machine
  - Changing the size of the volumes connected to the virtual machine

- Performing Storage vMotion on the virtual machine

Use AdvancedCopy Manager Copy Control Module for secondary backup for Clone backup. As the Clone backup volume is a FTV, the usable range is the same as that of the existing FTV.

Clone backup volume information can be checked on Web Console.

Clicking the copy group name field in the **Clone Backup History** tab on the VVOL Backup History screen displays a list of copy group names used for the Clone backup in a dialog box. Clicking the link of the target copy group name in the dialog box moves to the Copy Group Detail screen, and the Clone backup volume information can be checked.



Refer to the *AdvancedCopy Manager Operation Guide for Copy Control Module* for details about AdvancedCopy Manager Copy Control Module.



Do not connect the Clone backup volume to the server. As the Agent-based Advanced Copy operation requires connecting the Clone backup Volume to a server in which the AdvancedCopy Manager's agent is installed, this cannot be used.



There are QuickOPC sessions between the Clone backup volume and the backup source Virtual Volume. For this reason, the copy from the Clone backup is a cascade copy.

## 2.4.7 Notes on Operation

---

### General Notes

- Install VMware Tools in the virtual machine.
- In the following cases, the virtual machine backup cannot be used.
  - When the ETERNUS SF Manager service is not started
  - When the ETERNUS VASA Provider service is not started
  - When the VMware vCenter Server is not started
  - When the VMware ESXi belonging to the virtual machine to be operated is not set to maintenance mode
  - When due to irregularities in the network environment, communication is not possible with the VMware vCenter Server and the ETERNUS Disk storage system (port blocked, firewall, timeout due to delay on communicating party, server IP address change, physical communication route errors, etc.)
- When backing up, restoring or referencing/deleting backup information, do not change the virtual machine configuration or operate Snapshot on the VMware vCenter Server.

## 2.5 Configuration Change/Maintenance of Storage System

---

### 2.5.1 Management Server Environment Configuration Change

---

Refer to the following for the method of changing the Management Server environment configuration:

- "Changing Operating Environment" in the *AdvancedCopy Manager Operation Guide*

- "Changing Operating Environment" in "Maintenance of Manager" in the *Storage Cruiser Operation Guide*

## 2.5.2 VVOL Datastore Configuration Change

---

Refer to ["2.3.3 VVOL Datastore Management"](#).

## 2.5.3 VMware Environment Configuration Change

---

### Virtual Machine Configuration Change

Refer to "VMware Server Node" in "Environment Configuration" in the *Storage Cruiser Operation Guide*.

### Deletion of Virtual Machine

The procedure to delete a virtual machine is as follows:

1. If virtual machine backup is being automatically executed, pause automatic execution of the virtual machine backup from Web Console.  
Refer to "Automatic Execution Setting of Virtual Machine Backup" in the *Web Console Guide* for the method of pausing automatic execution.
2. Delete the virtual machine from VMware vCenter Server.
3. Delete the virtual machine from this product from Web Console.  
Refer to "Delete Server" in the *Web Console Guide* for the deletion operation method.

#### Point

---

When using the Clone backup capture of the virtual machine backup function, even if the virtual machine is deleted, the Clone backup history is not deleted. For this reason, even after deleting the virtual machine, the virtual machine can be restored from the Clone backup.

Refer to ["Clone Backup History Information"](#) for deletion of Clone backup history.

---

#### Note

---

When using the virtual machine backup function, note the following points:

- When the Snapshot is deleted from this product without being deleted from the VMware vCenter Server  
The Snapshot backup history managed by this product is deleted, but the Snapshot on the VMware vCenter Server is not deleted. When the Snapshot is unnecessary, delete it from VMware vCenter Server.  
Further, when the deleted virtual machine power is turned on, or an update is made of the VM host from this product, the registration of this product and policy are reset. The virtual machine backup operation is then started based on the set policy. When the backup operation is unnecessary, update the policy and disable the backup operation.
  - When the Snapshot is just deleted from the VMware vCenter Server without being deleted from this product  
If the virtual machine backup is being automatically executed on the virtual machine, the automatic execution is stopped. However, as the Server registration information is not deleted from this Server, perform deletion processing as necessary.
- 

### VM Host Configuration Change

Adding VM Host

Add and register the VM host on this product.

Refer to ["VM Host"](#) in ["2.2.3 Configuration and Registration of Managed Devices"](#) for registering the VM host.

## Changing/Deleting VM Host Configuration

Refer to "VMware Server Node" in "Environment Configuration" in the *Storage Cruiser Operation Guide*.

## VMware vCenter Server Configuration Change

### Adding VMware vCenter Server

Add VMware vCenter Server to this product and register.

Refer to "VMware vCenter Server" in "2.2.3 Configuration and Registration of Managed Devices" for registering VMware vCenter Server.

### Change VMware vCenter Server Registration Information

Change the VMware vCenter Server registration information registered in this product.

The following items comprise the VMware vCenter Server registration information.

- IP address
- Port number
- User
- Password

When changing the IP address, delete the VMware vCenter Server and re-register after changing the registration information. Change the other items from the Register/Reload screen after selecting the VMware vCenter Server to be changed from Web Console.



See

Refer to "Register/Reload VMware vCenter Server and Change User Information of VMware vCenter Server" and "Delete VMware vCenter Server" in "Operations for VMware vCenter Server" in the *Web Console Guide* for the operation method with Web Console.

### Deletion of VMware vCenter Server

Delete the VMware vCenter Server information registered in this product.

Do not delete the VMware vCenter Server that manages the VM carrying out the backup.

Refer to "Delete VMware vCenter Server" in "Operations for VMware vCenter Server" in the *Web Console Guide* for the operation method with Web Console.

## 2.5.4 Maintenance of Management Server

---

This section explains the maintenance of the Operation Management Server.

In case an accidents, back up the operation management environment for this product.

When installing this product and changing the settings of the Management Server, be sure to make a backup. Additionally, as some functions undergo automatic operation and information update, we recommend performing a regular backup.



Information

The ETERNUS VASA Provider operating procedures and the terms described in this sub section may vary with the version level of ETERNUS VASA Provider.

### 2.5.4.1 Backup/Restoration of Management Server Environment

Back up and restore the information required for behaviors of ETERNUS SF Manager and ETERNUS VASA Provider.

## Backup

Back up the necessary information on the ETERNUS SF Manager and ETERNUS VASA Provider.

- Backup of ETERNUS SF Manager

Refer to "Backup of Manager" in "Maintenance of Administrative Environment" in the *Storage Cruiser Operation Guide*.

- Backup of ETERNUS VASA Provider

The necessary task differs depending on the version level of ETERNUS VASA Provider. Refer to the ETERNUS VASA Provider manual of the version level being used and back up the files that are needed to operate ETERNUS VASA Provider as required.

## Restoration

Restore the necessary information on the ETERNUS SF Manager and ETERNUS VASA Provider.

- Restoration of ETERNUS SF Manager

Refer to "Restoring Manager" in "Maintenance of Administrative Environment" in the *Storage Cruiser Operation Guide*.

- Restoration of ETERNUS VASA Provider

The necessary task differs depending on the version level of ETERNUS VASA Provider. Refer to the ETERNUS VASA Provider manual of the version level being used and restore the files that are needed to operate ETERNUS VASA Provider as required.

If the Management Server is created on a virtual machine, take the following steps to perform backup/restore operations.

## Backup

Make a virtual machine clone, on which the Management Server is created.

## Restoration

Take the following steps to perform restore operation.

1. Start the virtual machine clone made at backup.  
If the clone was made with the power on at backup, restart the virtual machine after started.
2. Restore the system configuration information.  
Perform the **Reload Conf.** operation on Web Console for all the ETERNUS Disk storage systems registered on this product.
3. Restore the configuration information about the VMware vSphere Virtual Volumes environment.  
Use the "esfadm esfdata restore" command to restore the configuration information about the VMware vSphere Virtual Volumes environment from the system.

As a result of this operation, if the VVOL datastores and the virtual machines created by the VMware vSphere Virtual Volumes function are correctly displayed on the vSphere Web Client, restore has been properly performed.

## 2.5.4.2 Collecting Troubleshooting Information

When a problem occurs in the Management Server, collect troubleshooting information for both ETERNUS SF Manager and ETERNUS VASA Provider.

- Collecting Troubleshooting Information for ETERNUS SF Manager

Refer to "Collecting Troubleshooting Information" in "Troubleshooting" in the *Storage Cruiser Operation Guide*.

- Collecting Troubleshooting Information for ETERNUS VASA Provider

Refer to the ETERNUS VASA Provider manual and collect troubleshooting information for ETERNUS VASA Provider.

### 2.5.4.3 Starting and Stopping the Services

To start or stop the services of the Management Server, the following services must be started or stopped. Note that there is a correct order for starting and stopping the services. Refer to "Starting and Stopping the ETERNUS SF Manager Services" in the *Storage Cruiser Operation Guide* for the procedure to start and stop the services.

- ETERNUS SF Manager
- ETERNUS VASA Provider

#### Note

If the above services are stopped, the following operations become unavailable in VMware vSphere Virtual Volumes environments.

- Operations using this product (such as backing up virtual machines)
- System configuration changes (such as starting and stopping virtual machines, or adding, deleting, and moving Virtual Volumes)

Make sure the business is not affected before stopping the services.

## 2.5.5 Changing Configuration of Supported Devices

### For Applying Model Upgrade Options for ETERNUS Disk Storage System

The device configuration is changed when applying Model upgrade options for ETERNUS Disk storage system. Perform the following operation after applying Model upgrade options for ETERNUS Disk storage system.

Before Applying Model Upgrade Options	After Applying Model Upgrade Options	Operation
ETERNUS DX200 S5	ETERNUS DX500 S5	Perform the procedure of "Operation on Model Upgrade from DX200 S5 to DX500 S5, from DX200 S4 to DX500 S4, from DX200 S3 to DX500 S3, from AF250 S3 to AF650 S3" in the <i>Web Console Guide</i> .
ETERNUS DX200 S4	ETERNUS DX500 S4	
ETERNUS DX200 S3	ETERNUS DX500 S3	
ETERNUS AF250 S3	ETERNUS AF650 S3	



# Chapter 3 Virtual Machine Operation by Virtual Machine Administrator/User

This chapter describes the operating procedure of the VM administrator and the VM user in a VMware vSphere Virtual Volumes environment.

## Note

- When ETERNUS VASA Provider is stopped, the status of VVOL datastore on vSphere Web Client is offline.
- After ETERNUS VASA Provider is restarted, the status of Storage Provider on vSphere Web Client may be Rescan Error. This is because VMware vCenter Server cannot recognize ETERNUS VASA Provider. Wait a few moments to execute Rescan and update the information.

In a case other than those above, if the status of Storage Provider becomes Rescan Error, multiple VMware vCenter Servers may manage a single ETERNUS VASA Provider. Check the ETERNUS VASA Provider registered status. To manage a single ETERNUS VASA Provider with multiple VMware vCenter Servers, ETERNUS VASA Provider that supports Multi vCenter Server is required. Check the version of the ETERNUS VASA Provider. Refer to the ETERNUS VASA Provider manual for details about Multi vCenter Server.

## Information

The vSphere Web Client operating procedures and the terms described in this chapter may vary with the version level of vSphere.

## 3.1 Virtual Machine Operation in VMware vSphere Virtual Volumes Environment

### 3.1.1 Summary of Operation

In a VMware vSphere Virtual Volumes environment, virtual machines can be operated with the policy related to the storage.

The VVOL datastore has various functions and the Virtual Volumes that are created there also has various functions. In relation to these functions, it is possible to specify the VVOL datastore selection criteria for locating the virtual machine and Virtual Volume settings.

#### VVOL Datastore Selection Criteria

Set the functions of the VVOL datastore in the policy. If the policy is set, the VVOL datastores that satisfy the policy become candidates for the virtual machine location.

#### VM and Virtual Volume settings

Set the functions of the Virtual Volume in the policy. If the policy is set, the settings for the policy are carried out automatically for the Virtual Volume that was created in the various operations related to the virtual machine and the creation of the virtual machine.

## Information

In the VMware vSphere Virtual Volumes, policies related to the storage are called "VM Storage Policies".

The functions that can be set as a policy for VMware vSphere Virtual Volumes are as follows:

- Virtual Machine Backup

- Automated Storage Tiering (Advanced)
- Automated QoS (Advanced)
- Cache (Advanced)
- Security (Advanced)

### Point

- When using functions described as "Advanced", understanding the storage and function mechanism is necessary. If a VVOL database is set with a name according to the operation purpose by the storage administrator, do not use the functions described as "Advanced" and select the VVOL datastore based on the name.
- When a policy is not specified, the default value for each function is set. Automated Storage Tiering, Cache, and Security all work according to the storage device and VVOL datastore configuration. Virtual machine backups and the Automated QoS function do not work.

### Note

- If the following events have occurred, contact the storage administrator because there is a possibility that an abnormality may occur in the Management Server.
  - Virtual machines or VVOL datastores are not properly recognized.
  - The storage service provider has become offline.
  - The following error events occur in various operations (create, delete, power on/off, create Snapshots, etc.) of a virtual machine:

```
Cannot complete file creation operation
Unable to load configuration file filePath
A general system error occurred
Failed to delete the virtual machine
File filePath was not found
```

- If VVOL datastore runs out of space, contact the storage administrator.

## 3.1.2 Operating Procedure

### Preparatory Work

To use a virtual machine in a VMware vSphere Virtual Volumes environment, the following preparations are required:

1. [Registration of VVOL Datastores](#)  
Register the VVOL datastore created by the storage administrator on the VM host.
2. [Creation of Policy](#)  
Create policies corresponding to the operational purpose.

### Creating Virtual Machine

By specifying the created policy, VVOL datastores that satisfy this policy can be listed. If you select the VVOL datastore that you want to use from among these, a Virtual Volume is created on this datastore and is set according to the policy.

### Point

In addition to creating a virtual machine, specify a policy for the various operations that need to select the VVOL datastores such as virtual machine clones and Storage vMotion.

## 3.2 Operation of VVOL Datastores

---

### 3.2.1 Registration of VVOL Datastores

---

The storage administrator registers the VVOL datastore in the VM host.

The vSphere Web Client operating procedure is as follows:

1. Rescan Storage Provider if a VVOL datastore is created in the storage system in "[2.3.3 VVOL Datastore Management](#)".
2. Select the VM host.
3. Click **Storage > New Datastore...** by right-clicking the mouse, or from Actions.
4. Operate according to the directions on the screen.

Specify "VVOL" for the datastore type. The VVOL datastore created by the storage administrator is displayed in the list for "Backing Storage Container". Select the VVOL datastore to register from this list.



.....  
You can set the datastore name when registering the VVOL datastore. The default is the name when created by the storage administrator. Unless the registered datastore name is a duplicate, continue to use that name without changing it.  
.....

## 3.3 Operation of Policies

---

### 3.3.1 Creation of Policy

---

When creating a virtual machine or performing various types of operations, create the policies in advance.

The vSphere Web Client operating procedure is as follows:

1. Click **VM Storage Policies** from **Home**.
2. Click the **Create a new VM storage policy** icon.
3. Operate according to the directions on the screen.

Under **Rule-Set**, if "com.fujitsu.eternus" is selected as **Rules based on data services**, the **Add rule** pull-down menu is displayed. From the pull-down menu, add the desired function and specify a value for each function.

From **Storage compatibility**, the VVOL datastore that satisfies the created policy is displayed in **Compatible storage**. If the VVOL datastore is not displayed in **Compatible storage**, redo the **Rule-Set** operation.



- .....
- You can add the following functions under **Add rule**.
    - Virtual Machine Backup
    - Automated Storage Tiering (Advanced)
    - Automated QoS (Advanced)
    - Cache (Advanced)
    - Security (Advanced)
  - Functions that are not added are set according the default value for that function.

- If the VVOL datastore that is selected by the specified policy is configured in multiple Tier pools, the Virtual Volume is created in the Tier pool that has less Virtual Volumes than the others.

### Note

- Do not use **Rules based on common capabilities** or **Rules based on tags**.
- Do not perform **Add another rule set**.

### Policy Application and Applicable Scope

The policy applicable scope varies with the function.

Table 3.1 Policy Applicable Scope

Function	Policy Applicable Target
Virtual Machine Backup	Virtual machine
Automated Storage Tiering (Advanced)	Tier pool or Virtual Volume
Automated QoS (Advanced)	Virtual Volume
Cache (Advanced)	Virtual Volume
Security (Advanced)	Tier pool

When selecting storage to create a virtual machine (selecting a datastore in which to store a virtual machine file), in order to apply the policy, select the VM Storage Policies for which the policy satisfying the operational requirements is specified.

The policies excluding "Virtual Machine Backup" are applied when creating a virtual machine. Refer to "[3.4.1 Creation of Virtual Machine](#)" for creation of virtual machine.

The "Virtual Machine Backup" policy is applied when a virtual machine is powered on.

The following functions are automatically restarted by property settings when the policy has been completely applied.

Table 3.2 Target for Policy Automatic Start

Function	Property	Value
Virtual Machine Backup	Operation Mode	Auto
Automated Storage Tiering (Advanced)	-	-
Automated QoS (Advanced)	Automated QoS Enable/Disable	Enable
Cache (Advanced)	Extreme Cache	Any(*1), Enable
Security (Advanced)	Data encryption	Any(*2), Enable

Hyphen(-): Started regardless of property settings.

\*1: When using the storage on which Extreme Cache or Extreme Cache Pool is installed.

\*2: When using an encrypted Tier pool.

The backup operation of a virtual disk (Virtual Volume) connected to a virtual machine is performed according to the policy set up for the virtual machine.

### Note

- If applying the policy failed, automatic operation of "Virtual Machine Backup", "Automated Storage Tiering (Advanced)", or "Automated QoS (Advanced)" is not started. For this reason, after creating a virtual machine, check that the policy is properly applied.  
Refer to "[3.3.3 Confirmation of Policy Application](#)" to check whether the policy is properly applied.

- If the applied policy includes "Automated QoS (Advanced)", Automated QoS is started for only Virtual Volumes to be monitored. When enabling Automated QoS for a Virtual Volume, change the settings of performance management so that the Virtual Volume is monitored by this product. Refer to "Instruction for Performance Management" in the *Storage Cruiser Operation Guide* for the method for changing settings.

### Policy Operating Condition

Policy settings (property value) and operating conditions are shown as follows.

Table 3.3 Settings (Property Value) and Operating Conditions in Policy

Function	Property	Value	Operating Condition
Virtual Machine Backup	Operation Mode	Auto or Manual	The license to use virtual machine backup functions is set up in the ETERNUS SF system.
	Clone Backup	Enable	Clone backup VVOL datastore is created on the ETERNUS SF system.
Automated Storage Tiering (Advanced)	Number of Layers	2 or 3	The license to use Automated Storage Tiering is set up in the ETERNUS SF system.
Automated QoS (Advanced)	Automated QoS Enable/Disable	Enable	The license to use Automated QoS is set up in the ETERNUS SF system, and Automated QoS is enabled in the ETERNUS SF system.
	Tune by Quota Share	On	The license to use Automated Storage Tiering is set up in the ETERNUS SF system.
Cache (Advanced)	Extreme Cache	Enable	Extreme Cache or Extreme Cache Pool is installed on the storage device comprised of VVOL datastores.
Security (Advanced)	Data encryption	Enable	The storage device comprised of VVOL datastores supports the encryption function.

The following policies are explained.

- [Virtual Machine Backup](#)
- [Automated Storage Tiering \(Advanced\)](#)
- [Automated QoS \(Advanced\)](#)
- [Cache \(Advanced\)](#)
- [Security \(Advanced\)](#)

### 3.3.1.1 Virtual Machine Backup

This section describes the virtual machine backup policies.

#### Function to Select

To set the virtual machine backup policies, adding "Virtual Machine Backup" as a function when creating VM Storage Policies is required.

#### Property items

Properties that can be set as virtual machine backup policies are as follows.

Set the virtual machine backup policy for each virtual machine instead of each Virtual Volume.

Table 3.4 Property List

Property	Explanation	Default Values	Modifiable
Operation Mode	<p>Selects the operating mode for specifying the operating method of the virtual machine backup function.</p> <ul style="list-style-type: none"> <li>- Auto Uses the virtual machine backup function. Automatically executes a backup.</li> <li>- Manual Uses the virtual machine backup function. Backups can only be executed manually.</li> <li>- Disable Does not use the virtual machine backup function.</li> </ul> <p>Even if you select "Auto" or "Manual" for this item, if the following settings are done (settings that do not create backup), "Disable" is automatically set.</p> <ul style="list-style-type: none"> <li>- "0" is specified for <b>Number of Snapshot Generations</b>, and</li> <li>- "Disable" is specified for <b>Clone Backup</b>.</li> </ul>	Disable	Possible
Execution Period	<p>Selects the interval when automatically executing a backup. This item is only set when <b>Operation Mode</b> is set to "Auto".</p> <ul style="list-style-type: none"> <li>- Hourly Executed according to the specified execution interval. When this interval is selected, setting <b>Execution Interval(Hour)</b> is required.</li> <li>- Daily Executed every day at the time specified in <b>Execution Start Time</b>.</li> <li>- Weekly Executed on the specified day every week. When this interval is selected, setting <b>Execution Week</b> is required.</li> <li>- Monthly Executed on the specified day every month. When this interval is selected, setting <b>Execution Day</b> is required.</li> </ul>	Monthly	Possible
Execution Interval(Hour)	<p>When "Hourly" is set for <b>Execution Period</b>, the execution interval is selected on an hourly basis. The selectable intervals are 1, 2, 3, 4, 6, 8, or 12.</p>	12	Possible
Execution Week	<p>When "Weekly" is set for <b>Execution Period</b>, select the execution day. Multiple days of the week can be selected.</p>	Sun	Possible
Execution Day	<p>When "Monthly" is set for <b>Execution Period</b>, select the execution day. The dates that can be selected are from 1 - 31 or "Last". Only one can be selected. When selecting between 1 - 31, the backup occurs on the specified date. The backup will occur for the in months where the selected date does not exist.</p>	1	Possible

Property	Explanation	Default Values	Modifiable
	When selecting "Last", the backup will be performed on the last day of the month.		
Execution Start Time(Hour)	Selects the time (hour) for starting the automatic execution of the backup. Values between 0 - 23 can be selected. This item can only be enabled when <b>Operation Mode</b> is set to "Auto".	0	Possible
Execution Start Time(Minute)	Selects the time (minute) for starting the automatic execution of the backup. Values that can be selected are 0 - 55 (5 min increments). This item can only be enabled when <b>Operation Mode</b> is set to "Auto".	0	Possible
Number of Snapshot Generations	Selects the number of Snapshot backup generations. The number of generations that can be selected is between 0 - 28. When "0" is selected, Snapshot backup is not created. When using Single item restore, Snapshot backup is required. For this reason, select "1" or more for this item. When executing Clone backup alone, specify "Enable" for <b>Clone Backup</b> , and select "0" for this item. This item is only enabled when <b>Operation Mode</b> is set to "Auto" or "Manual".  When performing Snapshot backups that exceed the number of generations, the oldest generation is automatically deleted after performing the backup.	1	Possible
Quiesce guest file system	Selects whether or not to make the contents of the file system consistent at the time of the backup. This item is only enabled when <b>Operation Mode</b> is set to "Auto" or "Manual".  - Enable Makes the contents of the file system consistent at the time of the backup.  - Disable File system consistency is not ensured at backup.	Enable	Possible
Snapshot the virtual machine's memory	Selects whether or not too include the contents of the memory when acquiring a Snapshot backup. This item is only enabled when <b>Operation Mode</b> is set to "Auto" or "Manual".  - Enable Includes the contents of the memory when acquiring a Snapshot backup.  - Disable Does not include the contents of the memory when acquiring a Snapshot backup.	Disable	Possible
Clone Backup	Selects whether or not to create a Clone backup. This item is only enabled when <b>Operation Mode</b> is set to "Auto" or "Manual".  - Enable Acquires a Clone backup.	Disable	Possible

Property	Explanation	Default Values	Modifiable
	- Disable Does not acquire a Clone backup.		

### Point

When performing an automatic backup with an external scheduler, set **Operation Mode** to "Manual".

### About Backup Targets

Backups are performed in each virtual machine. The backup targets are the virtual disks comprising the virtual machine.

To perform backups, the following conditions must be satisfied.

- The datastore where the virtual machine configuration information is stored must be a VVOL datastore.  
Select a VVOL datastore from "Selection storage" when creating a virtual machine.
- All virtual machine disks comprising the virtual machine must be Virtual Volumes.

Virtual disks other than Virtual Volumes are not backup/restore targets depending on the type and settings. Also, regardless of the virtual disk type, when a virtual disk is in Independent (Persistent/Nonpersistent) mode, it is not a target for backup/restore.

Refer to the below for details.

Table 3.5 Availability of Backup/Restore for Virtual Disk

Virtual Disk Type	Snapshot Backup, Restoration from Snapshot Backups	Clone Backup, Restoration From Clone Backups	Single Item Restore
Virtual Volume	Y	Y	Y
VMFS	Y	N	N

Y: Process target

N: Not the process target

### Note

In restorations from a Clone backup, connection configuration for virtual disks that are excluded from a backup/restoration are not restored. Reconnect from VMware vCenter Server as necessary.

## 3.3.1.2 Automated Storage Tiering (Advanced)

The section describes the Automated Storage Tiering policies.

### Function to Select

In order to set the Automated Storage Tiering policies, when creating VM Storage Policies, adding "Automated Storage Tiering (Advanced)" as a function is required.

### Property Items

Properties that can be set as Automated Storage Tiering policies are as follows.

Table 3.6 Property List

Property	Explanation	Default Values	Modifiable
Number of Layers	Sets the number of layers in the Tier pool included in the VVOL datastore. VVOL datastores that have a Tier pool of	Any	Not Possible



Property	Explanation	Default Values	Modifiable
	<p>the specified number of layers are candidates for locating a Virtual Volume.</p> <ul style="list-style-type: none"> <li>- Any All the VVOL datastores are candidates for locating a Virtual Volume. Each Quota Share setting for Low/Middle/High is not used. The newly created Virtual Volume is relocated based on the Tiering policy. When changing the created Virtual Volume policy, the Quota Share settings are not changed.</li> <li>- 1 Each Quota Share setting for Low/Middle/High is not used.</li> <li>- 2 <b>Low Quota Share(%)</b> and <b>High Quota Share(%)</b> must be set. Specify these two Quota Shares so that the total becomes 100. When setting both to 0, the Virtual Volume is relocated based on the Tiering policy. The <b>Middle Quota Share(%)</b> setting is not used.</li> <li>- 3 <b>Low Quota Share(%)</b>, <b>Middle Quota Share(%)</b>, and <b>High Quota Share(%)</b> must be set. Specify these Quota Shares so that the total becomes 100. When all are specified as 0, the Virtual Volume is relocated based on the Tiering policy.</li> </ul>		
Execution Mode	<p>Specifies the execution mode for Tier pools included in the VVOL datastore.</p> <ul style="list-style-type: none"> <li>- Any</li> <li>- Auto</li> <li>- Semi-Auto</li> <li>- Manual</li> </ul> <p>If "Any" is specified for <b>Execution Mode</b> or if "1" is specified for <b>Number of Layers</b>, a VVOL datastore that has a Tier pool with all of the above execution modes is set is selected.</p>	Any	Not Possible
Priority FTSP	<p>Specifies which sub-pool is located as a priority when new data is assigned to the Virtual Volume.</p> <ul style="list-style-type: none"> <li>- Auto</li> <li>- High</li> <li>- Middle</li> <li>- Low</li> </ul> <p>There are the following relations between <b>Priority FTSP</b> and <b>Number of Layers</b>.</p> <ul style="list-style-type: none"> <li>- If "1" or "Any" is specified for <b>Number of Layers</b> This property setting is not used.</li> </ul>	Auto	Possible

Property	Explanation	Default Values	Modifiable
	- If "2" is specified for <b>Number of Layers</b> "Middle" cannot be set for this property. If "Middle" is specified, applying the policy fails and the Compliance Status becomes "Noncompliant".		
Low Quota Share (%)	This is the volume capacity ratio for the Low sub-pool when relocating. Values between 0 -100 can be specified. If "1" or "Any" is set for <b>Number of Layers</b> , this property setting is not used.	0	Possible
Middle Quota Share (%)	This is the volume capacity ratio for the Middle sub-pool when relocating. Values between 0 - 100 can be specified. If "1", "2" or "Any" is set for <b>Number of Layers</b> , this property setting is not used.	0	Possible
High Quota Share (%)	This is the volume capacity ratio for the High sub-pool when relocating. Values between 0 - 100 can be specified. If "1" or "Any" is set for <b>Number of Layers</b> , this property setting is not used.	0	Possible



See

Refer to the *Storage Cruiser Operation Guide for Optimization Function* for details about each properties and Automated Storage Tiering.

### 3.3.1.3 Automated QoS (Advanced)

The section describes the Automated QoS policies.

Function to Select

In order to set the Automated QoS policies, when creating VM Storage Policies, adding "Automated QoS (Advanced)" as a function is required.

Property items

Properties that can be set as Automated QoS policies are as follows.

Table 3.7 Property List

Property	Explanation	Default Values	Modifiable
Automated QoS Enable/Disable	Specifies whether to use or not use the Automated QoS function.  - Any All the VVOL datastores are candidates for locating a Virtual Volume. According to the settings by the storage administrator the Automated QoS function is used.  - Enable VVOL datastores that include Tier pools where Automated QoS is possible are candidates for locating a Virtual Volume.  - Disable All the VVOL datastores are candidates for locating a	Any	Possible

Property	Explanation	Default Values	Modifiable
	<p>Virtual Volume. Regardless of the Tier pool configuration, the Automated QoS function is not used.</p> <p>When "Any" or "Disable" is selected, other property settings are not used.</p>		
Automated QoS:Priority	<p>Specifies the Automated QoS priority of the Virtual Volume.</p> <ul style="list-style-type: none"> <li>- Unlimited</li> <li>- High</li> <li>- Middle</li> <li>- Low</li> <li>- Set Response Time</li> <li>- Not Set</li> </ul> <p>The <b>Target Response Time(msec)</b> setting is are only enabled when "Set Response Time" is specified.</p>	No Set	Possible
Target Response Time (msec)	<p>Specifies the target response time for Automated QoS. Values between 0 - 10,000 can be specified.</p> <p>This property is enabled only when "Set Response Time" is specified for the <b>Automated QoS:Priority</b> property.</p>	0	Possible
Tune by Quota Share	<p>Specifies whether to link to Automated Storage Tiering.</p> <ul style="list-style-type: none"> <li>- On VVOL datastores that include the following Tier pools are candidates for relocating a virtual machine, and Automated Storage Tiering is linked for the generated Virtual Volume. <ul style="list-style-type: none"> <li>- The Tiering policy of Automated Storage Tiering is applied.</li> <li>- The <b>Execution Mode</b> of Automated Storage Tiering is "Auto".</li> <li>- There are two or more layers.</li> </ul> </li> <li>- Off Regardless of the Tier pool configuration, this is not linked to Automated Storage Tiering.</li> </ul>	Off	Possible

### Note

When "On" is specified for **Tune by Quota Share**, specify "Any" for **Number of Layers** of "Automated Storage Tiering (Advanced)".

### See

Refer to the *Storage Cruiser Operating Guide Optimization Function* for details about each property and the Automated QoS.

### 3.3.1.4 Cache (Advanced)

This section describes the Cache policies.

Function to Select

In order to set the Cache policies, when creating VM Storage Policies, adding "Cache (Advanced)" as a function is required.

Property items

Properties that can be set as Cache policies are as follows.

Table 3.8 Property List

Property	Explanation	Default Values	Modifiable
Extreme Cache	<p>Specify whether to use the Extreme Cache function.</p> <ul style="list-style-type: none"> <li>- Any <ul style="list-style-type: none"> <li>- If creating a virtual machine Where an Extreme Cache or Extreme Cache Pool is installed in the storage device comprising the VVOL datastore selected by the storage user, the Extreme Cache or Extreme Cache Pool is enabled.</li> <li>- After creating a virtual machine Follows the current settings.</li> </ul> </li> <li>- Enable VVOL datastores of the storage device that is installed with Extreme Cache or Extreme Cache Pool are candidates for locating a Virtual Volume. Extreme Cache or Extreme Cache Pool is enabled for the created Virtual Volume.</li> <li>- Disable Regardless of whether Extreme Cache or Extreme Cache Pool is installed in the storage device, the Extreme Cache or Extreme Cache Pool is disabled for the created Virtual Volume.</li> </ul>	Any	Possible

### 3.3.1.5 Security (Advanced)

This section describes the Security policies.

Function to Select

In order to set the Security policies, when creating VM Storage Policies, adding "Security (Advanced)" as a function is required.

Property items

Properties that can be set as Security policies are as follows.

Table 3.9 Property List

Property	Explanation	Default Values	Modifiable
Data encryption	<p>Specifies whether to create an encrypted Virtual Volume.</p> <ul style="list-style-type: none"> <li>- Any Regardless of encryption, All the VVOL datastores are candidates for locating a Virtual Volume.</li> </ul>	Any	Not Possible

Property	Explanation	Default Values	Modifiable
	<ul style="list-style-type: none"> <li>- Enable VVOL datastores that include encrypted Tier pools are candidates for locating a Virtual Volume.</li> <li>- Disable VVOL datastores that include non-encrypted Tier pools are candidates for locating a Virtual Volume.</li> </ul>		

### 3.3.2 Change of Policy

There are two methods for changing virtual machine policies. These are operated from the vSphere Web Client.

#### When Changing the Policy for Only One Virtual Machine

When the same policy is applied to multiple virtual machines, create a new policy and apply it to a virtual machine whose policy is to be changed. When applying another policy to a virtual machine, perform the procedure in "[Applying Another Policy to Virtual Machine](#)".

#### When Changing the Policy All at One Time

When a policy is changed, the policy settings of all the virtual machines to which the policy is applied can be changed all at one time. To edit a policy, perform the procedure in "[Editing Policy](#)".

The vSphere Web Client operating procedure is as follows:

#### Applying Another Policy to Virtual Machine

1. Select the virtual machine.
2. Click **Policies** on the **Manage** tab.
3. Click **Edit VM Storage Policies...**
4. Select and apply the policy.
5. Perform the procedure in "[3.3.3 Confirmation of Policy Application](#)".

#### Editing Policy

1. Click **VM Storage Policies** from **Home**.
2. Select the policy to edit.
3. Click **Edit VM Storage Policies...**
4. Edit the policy.  
The method of editing is the same as that of "[3.3.1 Creation of Policy](#)".
5. Specify when to apply the edited policy.  
When applying right away, policies on all virtual machines where the policy is applied are changed simultaneously.  
When applying later, apply the procedure in "[Applying Another Policy to Virtual Machine](#)".
6. Perform the procedure in "[3.3.3 Confirmation of Policy Application](#)".

Policy change is performed in the background as with policy application.



#### Note

- Do not change items described as "Not Possible" in "Modifiable" in the table of each function in "[3.3.1 Creation of Policy](#)". When changed, the Compliance Status becomes "Noncompliant".

- When changing the policy, do not change the following properties. If they are changed, their Compliance Status becomes "Noncompliant". Also, the escs11301 message is displayed on the Event screen of VMware vCenter Server and on the Event Log screen of Web Console. Take action according to the message.

Table 3.10 Target Whose Policy Cannot Be Changed

Function	Property
Automated Storage Tiering (Advanced)	Number of Layers, Execution Mode
Security (Advanced)	Data encryption

- If the escs11002 message is output when applying the policy, perform the procedure in "Editing Policy" to change the policy.
- When specifying storage migration using Storage vMotion, if the "Virtual Machine Backup" property in the policy is also specified to be changed, it remains as before changed. Therefore, upon completion of Storage vMotion, reapply the policy with the following procedure:
  1. Select the virtual machine that performed Storage vMotion.
  2. Click **Policies** on the **Manage** tab.
  3. Click **Edit VM Storage Policies...**
  4. Click **OK**.

### 3.3.2.1 Virtual Machine Backup

All property settings can be changed.

#### Operation Mode

When changing to "Auto" or "Manual", the backup operation starts according to the set value.

#### Point

When performing an automatic backup with an external scheduler, select "Manual".

#### Note

Even if you select "Auto" or "Manual", if the following settings are done (settings that do not create backup), "Disable" is automatically set.

- "0" is specified for **Number of Snapshot Generations**, and
- "Disable" is specified for **Clone Backup**.

When changing to "Disable", a backup cannot be performed. If the following resources have been acquired before changing to "Disable", these resources continue to remain, and a restore is possible.

- Snapshot backup (Snapshot backup history)
- Clone backup (Clone backup history)

#### Point

Backup histories are not automatically deleted. To delete backup histories, ask the storage administrator.

The following changes are only effective when **Operation Mode** is set to "Auto" or "Manual".

### Execution Period / Execution Start Time

This is only enabled when the **Operation Mode** is set to "Auto".

The changed settings are reflected immediately and automatic operation is started according to the settings after the change.

### Number of Snapshot Generations

The settings after the change are reflected when the next Snapshot is executed. When saved generations are reduced, the Snapshot backups that are generation-overflows are deleted when the next backup is executed.

When this item is changed to "0" and **Clone Backup** is set to "Disable", **Operation Mode** is automatically set to "Disable". For this reason, the Snapshot backups already created are not deleted. When Snapshot backups are not required, ask the storage administrator to delete Snapshot backups.

### Clone Backup

The settings after the change are reflected when the next backup is executed.

When changing from "Disable" to "Enable", the Clone backup is taken when the next backup is executed.

When changing from "Enable" to "Disable", a Clone backup is not taken when the next backup is executed. However, as the created Clone backup is not deleted, restoring from the created Clone backup is possible. When Clone backup is not required, ask the storage administrator to delete Clone backup.

### Quiesce guest file system / Snapshot the virtual machine's memory

The settings after the change are reflected when the next Snapshot is executed. From the next backup on, the Snapshot backup is executed with the specified option.

### Point

When changing the virtual machine backup function policy, update the policy for all virtual machines or objects ("VM home") representing the virtual machine from the update screen.

## 3.3.2.2 Automated Storage Tiering (Advanced)

The property settings other than **Number of Layers** or **Execution Mode** can be changed.

The settings after change are reflected to the next relocation.

### Priority FTSP

Only when the number 2 or 3 is specified for **Number of Layers**, the settings can be changed.

### Low Quota Share (%)

Only when the number 2 or 3 is specified for **Number of Layers**, the settings can be changed.

### Middle Quota Share (%)

Only when the number 3 is specified for **Number of Layers**, the settings can be changed.

### High Quota Share (%)

Only when the number 2 or 3 is specified for **Number of Layers**, the settings can be changed.

### Point

When managing virtual machines with this product according to a policy designed by storage administrators, specify "Any" for **Execution Mode** and change the policy.

## 3.3.2.3 Automated QoS (Advanced)

All the property settings can be changed.

### Automated QoS Enable/Disable

When this property value is changed to "Enable", Automated QoS is started according to the set value.  
When this property value is changed to "Disable", Automated QoS is stopped.

Only when **Automated QoS Enable/Disable** is set to "Enable", the following changes are effective.  
The set value after change is reflected to the next automatic tuning.

### Automated QoS:Priority

Only when this property value is changed to "Set Response Time", the property of **Target Response Time (msec)** can be set.

### Target Response Time (msec)

The property value can be changed only when "Set Response Time" is specified for **Automated QoS:Priority**.

### Tune by Quota Share

When the property value is changed from Off to On, this operation is collaborated with Automated Storage Tiering from the next execution of automatic tuning.

When the property value is changed from On to Off, this operation is not collaborated with Automated Storage Tiering from the next execution of automatic tuning.

### Point

- When enabling Automated QoS for a Virtual Volume, change the settings of performance management so that the Virtual Volume is monitored by this product. Refer to "Instruction for Performance Management" in the *Storage Cruiser Operation Guide* for the method for changing settings.
- When managing virtual machines with this product according to a policy designed by storage administrators, specify "Any" for **Automated QoS Enable/Disable** and change the policy.

## 3.3.2.4 Cache (Advanced)

Settings can be changed. The changed settings are immediately reflected.

### Point

When managing virtual machines with this product according to a policy designed by storage administrators, specify "Any" for **Extreme Cache** and change the policy.

## 3.3.2.5 Security (Advanced)

Settings cannot be changed.

## 3.3.3 Confirmation of Policy Application

---

Confirm from vSphere Web Client whether virtual machines are running according to the policy.

The vSphere Web Client operating procedure is as follows:

1. Check whether the policy application has been finished.

To display an event overview, click **Events**.

When the following message is output in the event overview, the policy application has been finished.

```
escs11004 The compliance result was changed. policy=policy, target=target
```

When the following message is output, review the policy content and [change policy](#). If the cause is unknown, contact to the storage administrator.



```
escs11002 Applying the policy failed. policy=policy, target=target, detail=detail
```

### Point

- Those messages are displayed for each Virtual Volume. Since a virtual machine is comprised of multiple Virtual Volumes, multiple messages are displayed for one virtual machine.
- The message output when the policy application has been finished can be confirmed on the Event Log screen, as well.
- The Compliance Status is displayed as "Compliant" until the policy application has been finished.

#### 2. Confirm the Compliance Status.

To display the latest Compliance Status, it is required to collect the information from the ETERNUS SF system. Take the following steps to perform that:

- a. Select a target virtual machine.
- b. Click the **Monitor** Tab.
- c. Select **Policies** and click **Refresh the storage policy compliance**.

If the virtual machine is operating in accordance with the policy, "Compliant" is displayed in Compliance Status. Otherwise, "Noncompliant" is displayed.

The following are the cases where "Noncompliant" is displayed:

- The policy settings are not correct.
- The settings of the ETERNUS SF system do not meet the operating conditions of the policy (the system cannot be operated according to the policy).

### Note

- If "Virtual Machine Backup" is included in the applied policy and the created virtual machine is not powered on, power it on. Confirmation of policy application is not executed for "Virtual Machine Backup" before the power of the virtual machine turns on.
- After having created a virtual machine, the following property cannot be changed. If a storage administrator changes the policy design after having created a virtual machine, the Compliance Status is displayed as "Noncompliant".

Function	Property
Automated Storage Tiering (Advanced)	Number of Layers, Execution Mode

- When the applied policy satisfies the following conditions, the Compliance Status may be displayed as "Noncompliant".
  - **Low Quota Share(%)**, **Middle Quota Share(%)**, or **High Quota Share(%)** of "Automated Storage Tiering (Advanced)" is set, and
  - "On" is specified for **Tune by Quota Share** of "Automated QoS (Advanced)".

When the Compliance Status is displayed as "Noncompliant", take the following steps to apply the changed policy:

1. Click **VM Storage Policies** from **Home**.
2. Select the policy to edit.
3. Click **Edit VM Storage Policies...**
4. Edit the policy.  
After selecting **Rule Set 1**, select "Any" for **Number of Layers** of "Automated Storage Tiering (Advanced)" to click **OK**.

5. Specify when to apply the edited policy.  
When applying right away, policies on all virtual machines where the policy is applied are changed simultaneously.  
When applying later, apply the procedure in "[Applying Another Policy to Virtual Machine](#)".
6. Perform the procedure in "[3.3.3 Confirmation of Policy Application](#)".



See

Refer to the *Messages* for details about message.

### 3.3.4 Deletion of Policy

---

The policies not in use can be deleted.

The vSphere Web Client operation procedure is as follows:

1. Click **VM Storage Policies** from **Home**.
2. Select the policy to be deleted and right-click.
3. Click **Delete**.

## 3.4 Operation of Virtual Machine

---

### 3.4.1 Creation of Virtual Machine

---

Create a virtual machine using the Virtual Volume from VMware vCenter Server.

The vSphere Web Client operating procedure is as follows:

1. Select the VM host.
2. Click **New Virtual Machine** > **New Virtual Machine...** by right-clicking the mouse, or from Action.
3. Operate according to the directions on the screen.  
By specifying the VM Storage Policies from **Selection storage**, the VVOL datastore that satisfies this policy is displayed in the list as "Compatible". Select the VVOL datastore to use from among these.
4. Perform the procedure in "[3.3.3 Confirmation of Policy Application](#)".



Point

- Selecting a VVOL datastore without specifying the VM Storage Policies is possible. In this case, the Virtual Volume is created with the default settings for the selected VVOL datastore.
- Virtual machine is automatically registered on the ETERNUS SF system by being powered on. At the same time, other virtual machines than VMware vSphere Virtual Volumes, which are on the VM host where the virtual machine exists, are also automatically registered.
- For Virtual Volumes whose VVOL type is "Data", the settings of Disk Provisioning specified for virtual machine are applied.



Note

- Do not create a virtual machine in manners other than listed above.

- Selecting an "Incompatible" datastore is possible. In this case, the Virtual Volume is not created in line with the policy and the Compliance Status is "Noncompliant". If a "Compatible" Datastore is not displayed, select another VM Storage Policies or create a new VM Storage Policies.
- A datastore comprised of Tier pools that satisfy VM Storage Policies and Tier pools that do not satisfy them is displayed as "Compatible". In the **Compatibility:** field is displayed a warning message that the datastore does not satisfy VM Storage Policies. However, no action is required.

### 3.4.2 Deletion of Virtual Machine

---

Delete a virtual machine.

The vSphere Web Client operating procedure is as follows:

1. Select the virtual machine.
2. Click **Delete from Disk** by right-clicking the mouse, or from Action.

#### Operation When Virtual Machine Backup Policy Is Set

In the state where the virtual machine backup is operated automatically for the virtual machine, if that virtual machine is deleted, automatic operation of the virtual machine backup for that virtual machine is stopped.

However, the definition of the virtual machine is not deleted from the ETERNUS SF system. When a Clone backup has been acquired, the Clone backup is not deleted as well.

If you want to delete the definition of the virtual machine from the ETERNUS SF system, contact the storage administrator.

#### Point

- Because the automatic operation of the virtual machine backup is stopped, there is no problem with the system operation. However, the definition of the virtual machine that does not exist continues to exist in the ETERNUS SF system so deleting the virtual machine definition is recommended.
- A Clone backup is required to recovery the virtual machine. Delete the Clone backup only when recovery of the virtual machine in question is not required.

### 3.4.3 Migration of Virtual Machine

---

Migrate a virtual machine.

The vSphere Web Client operation procedure is as follows:

1. Select the target virtual machine.
2. Right-click or click **Migrate...** from the Action pane.

#### Point

- The policy applied to the migration operation can be specified. Therefore, the pre-migration policy can be inherited or other policies can be applied.
- When specifying storage migration using Storage vMotion, if the "Virtual Machine Backup" property in the policy is also specified to be changed, it remains as before changed. Therefore, upon completion of Storage vMotion, reapply the policy with the following procedure:
  1. Select the virtual machine that performed Storage vMotion.
  2. Click **Policies** on the **Manage** tab.
  3. Click **Edit VM Storage Policy**.
  4. Click **OK**.

- When migrating a virtual machine between VM hosts using Storage vMotion or vSphere HA, virtual machine is automatically registered on the ETERNUS SF system by being powered on. At the same time, other virtual machines than VMware vSphere Virtual Volumes, which are on the VM host where the virtual machine exists, are also automatically registered.
- .....

## 3.5 Snapshot

---

### 3.5.1 Creation of Snapshot

---

Create a Snapshot in each virtual machine.

The vSphere Web Client operating procedure is as follows:

1. Select the virtual machine.
2. Click **Snapshots > Take Snapshot...** by right-clicking the mouse, or from Action.

### 3.5.2 Reference to Snapshot List

---

Refer to the created Snapshot list. The following Snapshots are displayed in the Snapshot list.

- Snapshots created with vSphere Web Client
- Snapshots created on the ETERNUS SF system with Auto Execution or Manual Execution

The vSphere Web Client operating procedure is as follows:

1. Select the virtual machine.
2. Click **Snapshots > Manage Snapshots...** by right-clicking the mouse, or from Action.

#### Name and Explanation of Snapshot Created with ETERNUS SF System

The following names are assigned to the Snapshot created with the ETERNUS SF system:

- Snapshot name

ESF\_YYYYMMDD\_hhmm

"YYYYMMDD\_hhmm" is the Snapshot start date and time. YYYY : year, MM : month, DD : date, hh : hours, mm : minutes.

For example, if the Snapshot is started on January 18th, 2015 at 4:30, the Snapshot name is as follows:

ESF\_20150118\_0430

- Explanation

Created\_by\_ESF

### 3.5.3 Reversion to Snapshot

---

A reversion is performed to the created Snapshot.

The vSphere Web Client operating procedure is as follows:

1. Select the virtual machine.
2. Click **Snapshots > Manage Snapshots...** by right-clicking the mouse, or from Action.
3. Select the Snapshot to recover.
4. Click **Revert to**.

## Point

A reversion to a Snapshot that was created with ETERNUS SF System is also possible. Refer to "[3.5.2 Reference to Snapshot List](#)" for the name and explanation of the Snapshot created on the ETERNUS SF system.

### 3.5.4 Single Item Restore From Snapshot

Single item restore from a Snapshot uses a temporary volume and restores each file from the Snapshot so that only the necessary files are recovered.

Single item restore can be executed only when the **Number of Snapshot Generations** is set to "1" or more in the virtual machine backup policy.

The procedure for executing Single item restore from a Snapshot is as follows:

#### Information

Operating system operations and expression on screen may vary with the version level of the operating system.

1. Determine the "Snapshot to Restore", "Disk where the Files to Restore Exist", and "Temporary Volume Hold Time".

- Snapshot to Restore

Determine the Snapshot to restore. Only Snapshots created with ETERNUS SF system can be restored.

Only one Snapshot can be selected. If a restoration from multiple Snapshots is necessary, repeat the procedure described in this section for each Snapshot.

#### Note

In a single instance of Single item restore, restoration from multiple Snapshots cannot be executed simultaneously. When files are restored from multiple Snapshots, the temporary volume must be repeatedly created and deleted for each Snapshot.

If you want to delete the temporary volume before the temporary volume hold time is exceeded, contact the storage administrator.

- Disk where the Files to Restore Exist

Determine the disk (VMDK filenames) within the Snapshots where the files to restore exist.

Multiple disks can be selected.

#### Note

The same number of temporary volumes are used as the number of disks selected here. For this reason, check whether there is sufficient space in the SCSI controllers of the virtual machine where the temporary volumes are connected.

If there is no space in the SCSI controllers of the virtual machine, temporary volumes cannot be connected to the virtual machine. Add a SCSI controller or prepare a free controller from within the existing controllers. Refer to the VMware manuals for the method of adding SCSI controllers.

If a free SCSI controller still cannot be prepared, reduce the number of selected disks.

- Temporary Volume Hold Time

Determine the time to keep the temporary volume connected to the virtual machine. The time can be specified with a range of 1 - 99 hours.

Because the temporary disk is automatically deleted when the specified time expires, estimate and determine the time required for the file recovery work.

2. Notify the storage administrator of the information determined in step 1 to request Single item restore (connection of temporary volume to virtual machine).
3. A work completion notification is received from the storage administrator.

Temporary volumes where the disk content is copied within the Snapshot are connected to the virtual machine. A temporary volume is created as the following attributes in the same VVOL datastore as Snapshot targeted for restore.

Attribute (*1)	Content
Disk Provisioning	Thin Provisioning
Virtual Device Node	SCSI
Disk Mode	Independent-type
VMDK File Name	ESF_TEMP_sourceVmdkFileName
Connection Destination	Located in order from controller 0(SCSI 0:x)

\*1: The term of each item may vary with the version level of vCenter Server.

4. Rescan the disk and partition.

- For Windows

On the virtual machine, rescan the disk from **Disk Management**.

#### Note

On the **Disk Management** screen, it may be prompted to initialize disk for the temporary volume. When prompted to initialize disk, cancel the rescan. Initializing disk causes all the contents of the temporary volume to be cleared.

- For Linux

On the virtual machine, rescan the disk and partition.

#### Example

On the virtual machine, execute the following command:

```
sfdisk -R deviceName
```

*deviceName*: Temporary volume device name (/dev/sd\*)

5. Mount a temporary volume on the virtual machine.

- For Windows

On the virtual machine, place a temporary volume online from **Disk Management** to assign a drive letter.

- For Linux

On the virtual machine, mount a temporary volume by executing the "mount" command.

6. Copy the files necessary to recovery from the temporary volume to the business volume.

7. Unmount the temporary volume from the virtual machine.

- For Windows

On the virtual machine, place the temporary volume offline from **Disk Management**.

- For Linux

On the virtual machine, unmount the temporary volume by executing the "umount" command.

## Note

---

- In Single item restore, disks are automatically added to the virtual machine. Therefore, if a compatible device is in use, and when performing a system restart with an existing temporary volume, device name misalignments may occur. Using device names that do not cause device name misalignments is recommended. For information regarding device name misalignments, refer to the OS manuals.
  - Do not create Snapshots while a temporary volume exists. The temporary volume could not be removed. Create Snapshots after removing the temporary volume.
  - Single item restore from a Snapshot of backed up Windows dynamic disks is unsupported.
- 

## 3.5.5 Deletion of Snapshot

---

Delete the created Snapshot.

The vSphere Web Client operating procedure is as follows:

1. Select the virtual machine.
2. Click **Snapshots > Manage Snapshots...** by right-clicking the mouse, or from Action.
3. Select the Snapshot to delete.
4. Click **Delete**.

## Note

---

Do not delete the Snapshot that was created with ETERNUS SF system from vSphere Web Client. Even if the Snapshot that was created with ETERNUS SF system is deleted from the vSphere Web Client, that Snapshot information is not deleted from the ETERNUS SF system history. In order to delete the Snapshot information from the ETERNUS SF system history, contacting the storage administrator to delete the Snapshot on the ETERNUS SF system is necessary.

---

## 3.6 Restoration

---

### 3.6.1 Restore at Time of Physical Failure

---

If restoration from a Snapshot is not possible due to a physical failure, restore using Clone backup. Restoration from the Clone backup can be executed only when the **Clone Backup** is set to "Enable" in the virtual machine backup policy.

Restoration from the Clone backup involves creating a new virtual machine based on the virtual machine definition information at the time of Clone backup, data is recovered there. The new virtual machine is created on the VM host (VMware ESXi) where the backup source virtual machine at the time of the Clone backup belongs.

## Note

---

- Because creating a new virtual machine is necessary, if a new virtual machine cannot be created in the restore destination VM host (VMware ESXi) or VMware vCenter Server (such as if the number of virtual machines has reached the maximum limit), a restore is not possible.
- The following information cannot be restored:
  - Virtual machine Snapshots
  - VM Storage Policies (Default policy of the restore destination VVOL datastore is used.)
  - Virtual machine BIOS settings (Default settings are used.)

- Virtual machine MAC address (A new MAC address is allocated.)
- Virtual disks not targeted for backup/restoration  
Refer to "[About Backup Targets](#)" in "[3.3.1.1 Virtual Machine Backup](#)" for details.

.....

The procedure for a restoration from Clone backup is as follows:

1. Determine the name of the newly created virtual machine.  
Any name can be specified.

 **Point**

.....

If the virtual machine where the Clone backup was acquired exists in the VMware vCenter Server, the same name at the time of the Clone backup cannot be specified. Changing the name of the newly created virtual machine or deleting the virtual machine with the same name is necessary.

.....

2. Notify the storage administrator of the information determined in step 1 to request a restore from Clone backup.
3. A work completion notification is received from the storage administrator.

The virtual machine that was restored using the Clone backup restoration exists in a state without a Snapshot or Clone backup. Execute the virtual machine backup after setting the appropriate policy based on the operating purpose of the virtual machine. Refer to "[3.3 Operation of Policies](#)" for configuration method of policies.



## Chapter 4 Command References

### 4.1 esfadm esfdata (Configuration Information Operation Command)

Use the following commands in the VMware vSphere Virtual Volumes operation management environment.

Command Name	Usage
esfadm esfdata	Operate configuration information



See

Refer to "Command References" in the *Storage Cruiser Operation Guide* for information on the command.

### 4.2 esfadm vvolvm info (Virtual Machine Information Display Command)

#### NAME

esfadm vvolvm info - Display of virtual machine information list

#### SYNOPSIS

```
esfadm vvolvm info -all
```

#### COMMAND PATH

```
$INS_DIR\Common\bin\esfadm vvolvm info
```

(\$INS\_DIR means "Program Directory" specified at the ETERNUS SF Manager installation.)

#### DESCRIPTION

This command displays a list of virtual machine information. Displayed information is as follows.

Field Title	Explanation
GuestName	Displays a VM guest name.
IPAddress	Displays the IP address of a VM guest.
HostName	Displays the VM host name in which the VM guest belongs to.
VMID	Displays the VMID of a VM guest.
OperationMode	Displays the operation mode of the backup policy.

#### OPTIONS

-all

Displays a list of virtual machine information managed by this product.

#### EXIT STATUS

=0: Completed successfully

>0: Terminated abnormally

## EXAMPLES

```
> esfadm vvolvm info -all
GuestName      IPAddress      HostName  VMID                                          OperationMode
-----
Guest01        192.0.2.10     esf-Host1 xxxxxxxx-xxxx-xxxx-xxxx-xxxxxxxxxxxxx Auto
Guest02        192.0.2.11     esf-Host1 xxxxxxxx-xxxx-xxxx-xxxx-xxxxxxxxxxxxx Manual
Guest03        192.0.2.12     esf-Host1 xxxxxxxx-xxxx-xxxx-xxxx-xxxxxxxxxxxxx Manual
Clone-Guest01 192.0.2.13     esf-Host1 xxxxxxxx-xxxx-xxxx-xxxx-xxxxxxxxxxxxx Disable
```

## 4.3 esfadm vvolvm backup (Virtual Machine Backup Command)

### NAME

esfadm vvolvm backup - Execution of a virtual machine backup

### SYNOPSIS

```
esfadm vvolvm backup -vmid vmid
```

### COMMAND PATH

```
$INS_DIR\Common\bin\esfadm vvolvm backup
```

(\$INS\_DIR means "Program Directory" specified at the ETERNUS SF Manager installation.)

### DESCRIPTION

This command executes a virtual machine backup in cooperation with the backup policy.

When "Enable" is set in **Clone Backup** of the backup policy, the copy group name of the Clone backup that was created at backup time is output as a result of the command. When "Disable" is set, a hyphen (-) is output as a result of the command.

### OPTIONS

-vmid *vmid*

Specifies the virtual machine VMID. VMID can be confirmed with the "[esfadm vvolvm info](#)" command.

### EXIT STATUS

=0: Completed successfully

>0: Terminated abnormally

### EXAMPLES

A virtual machine backup is executed, and the copy group name of the Clone backup created at the backup time is displayed.

```
> esfadm vvolvm backup -vmid xxxxxxxx-xxxx-xxxx-xxxx-xxxxxxxxxxxxx
VM_XXXXXXXX-XXXX-XXXX-XXXX-XXXXXXXXXXXXXXXXXXXXXXXXXXXXXXXXXXXX
```

### NOTES

- This command executes a backup in accordance with the virtual machine backup policy. If there are any processes running for the target virtual machine, the backup is executed after waiting for the process to finish.
- This command returns upon completion of a backup (logical copy).
- When this command is forcibly stopped, the backup continues executing, but the processed result cannot be collected. Check the status of backup on the Job Status pane or the VVOL Backup Management screen of Web Console.

- If a virtual disk other than a Virtual Volume is connected to a virtual machine, it cannot be a backup target according to the virtual disk type and setting. Refer to "[About Backup Targets](#)" in "[3.3.1.1 Virtual Machine Backup](#)" for details.