

PRIMECLUSTER™

Concepts Guide 4.2 (Oracle Solaris / Linux)

Copyright and Trademarks

Linux is a trademark or registered trademark of Mr. Linus Torvalds in the United States and other countries.

Oracle and Java are registered trademarks of Oracle and/or its affiliates. Other names may be trademarks of their respective owners.

EMC is a registered trademark of EMC Corporation in the United States or other countries.

PRIMECLUSTER is a trademark of Fujitsu Limited.

All other hardware and software names used are trademarks of their respective companies.

Requests

- No part of this documentation may be reproduced or copied without permission of FUJITSU LIMITED.
- The contents of this documentation may be revised without prior notice.

All Rights Reserved, Copyright (C) FUJITSU LIMITED 2003-2012.

Preface

Clustering technology overview

PRIMECLUSTER architecture

Cluster interconnect details

Reliant Monitor Services (RMS)

RMS configuration tools

SIS

Glossary

Abbreviations

Figures

Continued ►

Index

Contents

1	Preface	1
1.1	About this manual	1
1.2	Related documentation	2
1.3	Conventions	4
1.3.1	Notation	4
1.3.1.1	Prompts	4
1.3.1.2	Manual page section numbers	4
1.3.1.3	The keyboard	4
1.3.1.4	Typefaces	5
1.3.1.5	Example 1	5
1.3.1.6	Example 2	5
1.3.2	Command syntax	6
1.4	Important notes and cautions	6
1.5	Abbreviations	7
1.6	Editing record	7
2	Clustering technology overview	9
2.1	Introduction	9
2.2	High availability	10
2.2.1	Cluster interconnects	11
2.2.2	HA manager (RMS)	11
2.2.2.1	Protecting data integrity	11
2.2.2.2	RMS configuration tools	18
2.3	Scalability	18
3	PRIMECLUSTER architecture	21
3.1	Architectural overview	21
3.2	PRIMECLUSTER key design features	24
3.2.1	Modularity	24
3.2.2	Platform independence	24
3.2.3	Scalability	25
3.2.4	Availability	25
3.2.5	Guaranteed data integrity	25
3.3	PRIMECLUSTER components	26
3.3.1	CF	27
3.3.1.1	OSD	27
3.3.1.2	ICF	28
3.3.1.3	JOIN	28
3.3.1.4	ENS	29
3.3.1.5	Cluster Admin	29
3.3.1.6	Web-Based Admin View	29

Contents

3.3.1.7	SNMP	30
3.3.1.8	PRIMECLUSTER SF	30
3.3.1.9	SCON	40
3.3.2	RMS	43
3.3.2.1	RMS configuration tools	44
3.3.3	SIS	45
3.3.4	PAS	46
3.3.5	GDS	46
3.3.6	GFS	49
3.3.6.1	GFS Local file system (Solaris only)	49
3.3.6.2	GFS shared file system	50
3.3.6.3	Benefits	52
3.3.7	GLS	53
4	Cluster interconnect details	55
4.1	Overview	55
4.1.1	A cluster interconnect is different from a network	55
4.1.2	Network availability	56
4.1.3	Interconnect protocol	57
4.2	Cluster interconnect requirements	57
4.2.1	Redundancy	58
4.2.2	Routes	59
4.2.2.1	Heartbeats	59
4.2.3	Properties	60
4.2.3.1	Bandwidth	61
4.2.3.2	Latency	63
4.2.3.3	Reliability	64
4.2.3.4	Device interface	64
4.2.3.5	Security	65
5	Reliant Monitor Services (RMS)	67
5.1	RMS overview	67
5.1.1	Redundancy	68
5.1.2	Application switchover	69
5.1.2.1	Automatic switchover	70
5.1.2.2	Manual switchover	70
5.1.2.3	IP aliasing	70
5.1.2.4	Data integrity	70
5.2	RMS monitoring and switchover	71
5.2.1	Base monitor	71
5.2.2	Configuration file	72
5.2.2.1	Interdependencies	72
5.2.2.2	Object types	73
5.2.2.3	Object definitions	73

5.2.3	Scripts74
5.2.4	Detectors75
5.2.5	RMS environment variables76
5.3	RMS administration77
5.4	Customization options77
5.4.1	Generic types and detectors77
6	RMS configuration tools79
6.1	RMS configuration overview79
6.2	Configuration tool foundations81
6.3	RMS Wizard Kit and PCS Application Wizards82
7	SIS83
7.1	SIS overview83
7.1.1	Features84
7.1.2	Service nodes85
7.1.3	Gateway nodes85
7.1.4	Primary database node85
7.1.5	Backup database nodes85
7.1.6	Satellite nodes86
7.2	SIS design87
7.3	VIP load-balancing algorithms88
7.4	Proxy addresses88
7.5	Private addresses89
7.6	Failover89
	Glossary91
	Abbreviations	109
	Figures	113
	Index	115

Contents

1 Preface

This manual is a conceptual overview of the PRIMECLUSTER suite of products. PRIMECLUSTER is a fourth-generation clustering solution that provides high availability and scalability, independent of the operating system and hardware platform. Its modular software architecture consists of a basic set of modules deployed on all computers (nodes) in a cluster, plus optional modules that support specific types of applications. The modular architecture allows flexible clustering solutions for a wide range of customers—solutions that can be adapted to virtually any current or future platform.

 This guide describes all the components of PRIMECLUSTER. All of these components might not be available for all releases. The installation guides for products should be checked to verify which features are available for a specific platform.

This manual is intended for end users, system administrators, and support personnel. The purpose of this manual is to provide conceptual information only. It is not designed as a guide for administration, configuration, or installation (for more information, refer to the section “Related documentation” on page 2).

1.1 About this manual

This manual is organized as follows:

- The chapter “Clustering technology overview” on page 9 describes the concepts and benefits of clustering, including the main components of PRIMECLUSTER.
- The chapter “PRIMECLUSTER architecture” on page 21 explains the PRIMECLUSTER architecture and discusses the key features that PRIMECLUSTER provides.
- The chapter “Cluster interconnect details” on page 55 discusses the concepts, requirements, and design considerations of the cluster interconnect.
- The chapter “Reliant Monitor Services (RMS)” on page 67 introduces the basic concepts, components, and benefits of RMS.

- The chapter “RMS configuration tools” on page 79 explains the concepts of the RMS Wizard Tools, the RMS Wizard Kit, the PRIMECLUSTER Configuration Services (PCS) Wizards, and the PCS Application Wizards.
- The chapter “SIS” on page 83 introduces the basic concepts and components of the Scalable Internet Services (SIS).

1.2 Related documentation

The documents listed below provide details about related PRIMECLUSTER products. Please contact your sales representative for ordering information.

- *PRIMECLUSTER Installation and Administration Guide (Solaris)*—Provides instructions for installing and upgrading PRIMECLUSTER products.
- *PRIMECLUSTER Installation and Administration Guide (Linux)*—Provides instructions for installing and upgrading PRIMECLUSTER products.
- *Web-Based Admin View (Solaris) Operation Guide*—Provides information on using the Web-Based Admin View management GUI.
- *Web-Based Admin View (Linux) Operation Guide*—Provides information on using the Web-Based Admin View management GUI.
- *Cluster Foundation (CF) (Solaris) Configuration and Administration Guide*—Provides instructions for configuring and administering the PRIMECLUSTER Cluster Foundation.
- *Cluster Foundation (CF) Configuration and Administration Guide (Linux)*—Provides instructions for configuring and administering the PRIMECLUSTER Cluster Foundation.
- *Reliant Monitor Services (RMS) with PCS (Solaris, Linux) Configuration and Administration Guide*—Provides instructions for configuring and administering PRIMECLUSTER Reliant Monitor Services using the PCS (PRIMECLUSTER Configuration Services) interface.
- *Reliant Monitor Services (RMS) with Wizard Tools (Solaris, Linux) Configuration and Administration Guide*—Provides instructions for configuring and administering PRIMECLUSTER Reliant Monitor Services using the Wizard Tools interface.

- *Reliant Monitor Services (RMS) (Solaris, Linux) Troubleshooting Guide*—Describes diagnostic procedures to solve RMS configuration problems, including how to view and interpret RMS log files. Provides a list of all RMS error messages with a probable cause and suggested action for each condition.
- *Scalable Internet Services (SIS) (Solaris, Linux) Configuration and Administration Guide*—Provides information on configuring and administering Scalable Internet Services (SIS).
- *Global Disk Services (Solaris) Configuration and Administration Guide*—Provides information on configuring and administering Global Disk Services (GDS).
- *Global File Services (Solaris) Configuration and Administration Guide*—Provides information on configuring and administering Global File Services (GFS).
- *Global Link Services (Solaris) Configuration and Administration Guide: Redundant Line Control Function*—Provides information on configuring and administering the redundant line control function for Global Link Services (GLS).
- *Global Link Services (Solaris) Configuration and Administration Guide: Multipath Function*—Provides information on configuring and administering the multipath function for Global Link Services (GLS).
- *Data Management Tools (Solaris) Configuration and Administration Guide*—Provides reference information on the Volume Manager (RCVM) and File Share (RCFS) products. (Not available in all markets)
- *SNMP Reference Manual (Solaris, Linux)*—Provides reference information on the Simple Network Management Protocol (SNMP) product.
- Installation guides for all products—These documentation files are included as HTML files on the PRIMECLUSTER Framework CD. Release notices provide late-breaking information about installation, configuration, and operations for PRIMECLUSTER. Read this information first.
- *RMS Wizards documentation package*—Available on the PRIMECLUSTER CD. These documents provide information on topics including the configuration of file systems and IP addresses, or the different kinds of wizards.

1.3 Conventions

To standardize the presentation of material, this manual uses a number of notational, typographical, and syntactical conventions.

1.3.1 Notation

This manual uses the following notational conventions.

1.3.1.1 Prompts

Command line examples that require system administrator (or root) rights to execute are preceded by the system administrator prompt, the hash sign (#). Entries that do not require system administrator rights are preceded by a dollar sign (\$).

In some examples, the notation *node#* indicates a root prompt on the specified node. For example, a command preceded by *fuji2#* would mean that the command was run as user *root* on the node named *fuji2*.

1.3.1.2 Manual page section numbers

References to operating system commands are followed by their manual page section numbers in parentheses—for example, *cp(1)*.

1.3.1.3 The keyboard

Keystrokes that represent nonprintable characters are displayed as key icons such as **Enter** or **F1**. For example, **Enter** means press the key labeled *Enter*; **Ctrl-B** means hold down the key labeled *Ctrl* or *Control* and then press the **B** key.

1.3.1.4 Typefaces

The following typefaces highlight specific elements in this manual.

Typeface	Usage
Constant Width	Computer output and program listings; commands, file names, manual page names and other literal programming elements in the main body of text.
<i>Italic</i>	Variables in a command line that you must replace with an actual value. May be enclosed in angle brackets to emphasize the difference from adjacent text, e.g., <code><nodename>RMS</code> ; unless directed otherwise, you should not enter the angle brackets. The name of an item in a character-based or graphical user interface. This may refer to a menu item, a radio button, a checkbox, a text input box, a panel, or a window title.
Bold	Items in a command line that you must type exactly as shown.

Typeface conventions are shown in the following examples.

1.3.1.5 Example 1

Several entries from an `/etc/passwd` file are shown below:

```
root:x:0:1:0000-Admin(0000):/:/sbin/ksh
sysadm:x:0:0:System Admin.:/usr/admin:/usr/sbin/sysadm
setup:x:0:0:System Setup:/usr/admin:/usr/sbin/setup
daemon:x:1:1:0000-Admin(0000):/:
```

1.3.1.6 Example 2

To use the `cat(1)` command to display the contents of a file, enter the following command line:

```
$ cat file
```

1.3.2 Command syntax

The command syntax observes the following conventions.

Symbol	Name	Meaning
[]	Brackets	Enclose an optional item.
{ }	Braces	Enclose two or more items of which only one is used. The items are separated from each other by a vertical bar ().
	Vertical bar	When enclosed in braces, it separates items of which only one is used. When not enclosed in braces, it is a literal element indicating that the output of one program is piped to the input of another.
()	Parentheses	Enclose items that must be grouped together when repeated.
...	Ellipsis	Signifies an item that may be repeated. If a group of items can be repeated, the group is enclosed in parentheses.

1.4 Important notes and cautions

Material of particular interest is preceded by the following symbols in this manual:



Contains important information about the subject at hand.



Caution

Indicates a situation that can cause harm to data.

1.5 Abbreviations

Oracle Solaris might be described as Solaris, Solaris Operating System, or Solaris OS.

If "Solaris X" is indicated in the reference manual name of the Oracle Solaris manual, replace "Solaris X" with "Oracle Solaris 9 (Solaris 9)" or "Oracle Solaris 10 (Solaris 10)".

1.6 Editing record

Additions and changes	Section	Manual code
Added the description of the monitoring method for heartbeats.	4.2.2.1	J2S1-6481-02ENZ0(01)

2 Clustering technology overview

This chapter introduces the basic concepts and benefits of clustering, including the main components of PRIMECLUSTER.

This chapter discusses the following:

- The section “Introduction” on page 9 introduces the concepts of clustering technology.
- The section “High availability” on page 10 describes the concept of high availability (HA) and specifies how PRIMECLUSTER makes applications highly available.
- The section “Scalability” on page 18 describes the scalable benefits of PRIMECLUSTER.

2.1 Introduction

Clustering is imprecisely defined in distributed computing. In general, a cluster is a combination of computers or partitions of a computer (nodes) that act cooperatively to provide one or more of the following:

- High availability (HA)—Increasing service availability by using redundant components
- Scalability—Supplied by replicating application resources

This document focuses on cluster servers that provide HA and scalability as provided by the PRIMECLUSTER software suite. It does not discuss other kinds of clustering such as administrative clusters or scientific computing clusters.

Figure 1 illustrates a typical two-node cluster.

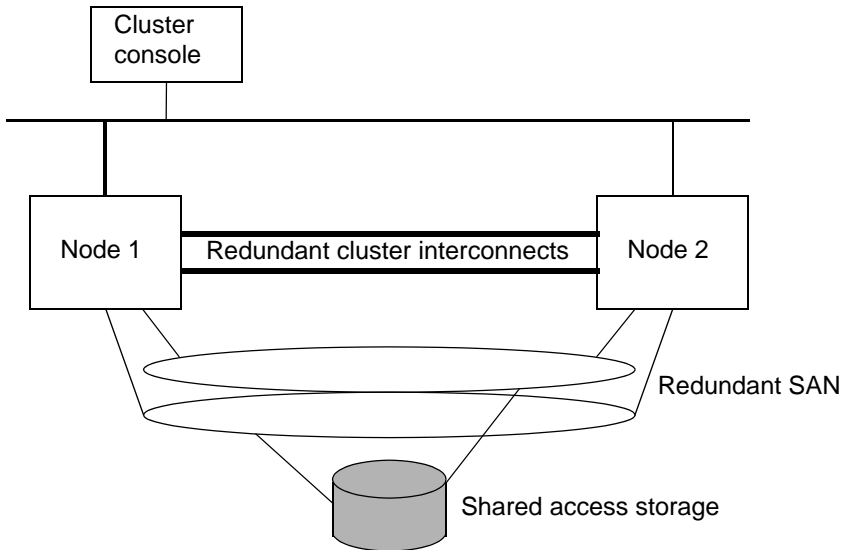

Figure 1: Typical two-node cluster

2.2 High availability

HA clusters use redundant components to compensate for a failure. Most HA clusters have a shared-storage environment; therefore, PRIMECLUSTER assumes, but does not require, that the cluster nodes connect to storage through a shared-access Storage Area Network (SAN). To provide redundancy, access to the SAN should include multiple host adapters in each node. Additionally, each node in the cluster must know if the other nodes in the cluster are operational. They do this by sending heartbeats over the interconnects.

2.2.1 Cluster interconnects

The cluster interconnect is the basic building block of a cluster. The following rules apply to the cluster interconnects:

- A node must be connected to a cluster interconnect to participate in a cluster.
- Multiple cluster interconnects provide redundancy, so that a failure in a component of one interconnect does not cause complete loss of contact within the cluster.

In addition to heartbeat requests, the cluster interconnects carry messages between nodes such as notification of events, communications between processes, and cluster file access. Additional details are discussed in the Chapter “Cluster interconnect details” later in this document.

2.2.2 HA manager (RMS)

Heartbeats between nodes help determine if a node is functional and if the node is able to communicate with other nodes in the cluster; however, heartbeats cannot determine if applications are running or if host adapters for the SAN are functional. PRIMECLUSTER provides Monitoring Agents (MAs), called detectors, that monitor the state of components for applications and the resources used by those applications. If a resource or application fails, the event is noted by the detector and reported to the HA manager, Reliant Monitor Services (RMS).

2.2.2.1 Protecting data integrity

RMS protects data integrity by performing the following tasks:

- Monitoring applications and their resources
- Ensuring that one application is only allowed to run on one node at a time (except parallel applications like Oracle RAC)
- Starting applications automatically only when all cluster nodes are in a known state (except when otherwise controlled due to settings of the `HV_AUTOSTARTUP_IGNORE` or `PARTIAL_CLUSTER` environment variables)

Monitoring applications

RMS is configured with rules specific to the applications and the configuration of the cluster. When a detector reports a failure, RMS takes the appropriate actions to recover the resources that are needed to provide continued availability of the application. The recovery actions are defined for every application and resource.

RMS recovery actions are as follows:

- Local recovery—The application's resources are recovered, and the application is restarted on the same cluster node.
- Remote recovery—The application's resources are recovered, and the application is restarted on another cluster node.

Cluster partition

A cluster partition is the result of multiple failures in the cluster interconnects such that some or all of the nodes continue to operate, but subsets of nodes cannot communicate with each other (this is sometimes called *split-brain syndrome*). Redundant cluster interconnects prevent partitions from occurring when only a single component has failed.

Figure 2 shows an example of two breaks in the cluster interconnects in which Node 1 and Node 2 can no longer communicate with each other. However, both nodes still have access to the SAN. Therefore, if recovery actions were taken independently on each node, two instances of an application could be running unaware on the two nodes of the cluster. If these instances were to make uncoordinated updates to their data, then data corruption would occur. Clearly, this condition cannot be allowed.

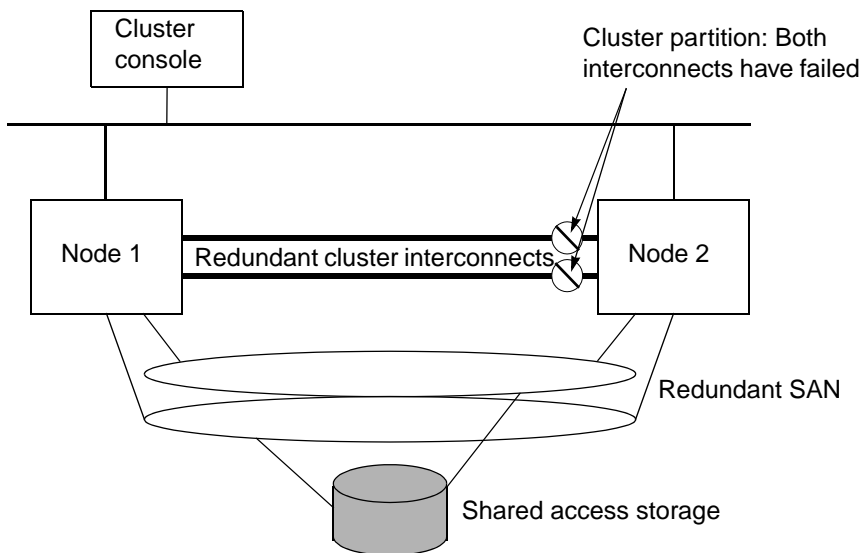

Figure 2: Cluster partition in two-node cluster

When a heartbeat failure occurs, each node sets the nodes from which they do not receive a heartbeat into a state called `LEFTCLUSTER`. The `LEFTCLUSTER` state is a middle state between `UP` and `DOWN` and indicates that the node is no longer part of the cluster, but its actual status is unknown. Before the nodes can take any recovery action, they must ensure that the cluster has a consistent state. The consistent state is sometimes called a quorum.

The terms consistent state and quorum are used interchangeably in `PRIMECLUSTER` documents. The cluster is in a consistent state when every node of the cluster is in a known state (`UP` or `DOWN`) and each node that is `UP` can communicate with every other node that is `UP`. The applications in the cluster should ensure that the cluster is in a consistent state before starting any operations that will alter shared data. For example, RMS ensures that the cluster is in a consistent state before it will start any applications in the cluster.

`PRIMECLUSTER` performs an elimination through a variety of methods, depending on the architecture of the nodes. When `PRIMECLUSTER` determines that a node is entering the `LEFTCLUSTER` state, it eliminates that node; thereby, recovering the application and guaranteeing data integrity.



The term *quorum* has been used in various ways in the literature to describe the handling of cluster partitions. Usually, this implies that when $(n + 1)/2$ nodes can see each other, they have a quorum and the other nodes will not perform any I/O operations. Because PRIMECLUSTER methods differ from the conventional meaning of quorum, the term *cluster integrity* was adopted. Some PRIMECLUSTER commands use the *quorum* term heritage, but in these cases *cluster integrity* is implied.

Cluster Integrity Monitor

The purpose of the Cluster Integrity Monitor (CIM) is to allow applications to determine when it is safe to perform operations on shared resources. It is safe to perform operations on shared resources when a node is a member of a cluster that is in a consistent state.

A consistent state is when all the nodes of a cluster that are members of the CIM set are in a known and safe state. The nodes that are members of the CIM set are specified in the CIM configuration. Only these nodes are considered when the CIM determines the state of the cluster.

When a node first joins or forms a cluster, the CIM indicates that the cluster is consistent only if it can determine the following:

- The status of the other nodes that make up the CIM set
- Whether the nodes of the CIM set are in a safe state

The method used to determine the state of the members of the cluster is sometimes called the CIM method. The CIM can use several different CIM methods; however, the following are available by default and are discussed here:

- NSM—The Node State Monitor (NSM) monitors the node states at fixed cycles, and it tracks the state of the nodes that are currently, or have been, members of the cluster. This is also known as the NULL or default CIM method. NSM is an integrated part of the PRIMECLUSTER CF.
- RCI—The RCI (Remote Cabinet Interface) is a special PRIMEPOWER environmental control and state network that can asynchronously both report on the state of the systems and control the systems on Solaris systems. (For more information, refer to the PRIMECLUSTER *Cluster Foundation (CF) Configuration and Administration Guide (Solaris)*.)

- **MMB**—The MMB (Management Board) is a special PRIMEQUEST environmental control and state network that can asynchronously both report the status of the systems and control the systems on Linux systems. (For more information, refer to the *PRIMECLUSTER Cluster Foundation (CF) Configuration and Administration Guide (Linux)*.)

PRIMEPOWER and PRIMEQUEST allow you to register and use multiple CIM methods. When multiple CIM methods are registered, CIM uses the lower priority method to check the state of a node only if the higher priority method cannot determine the node state. For example, if RCI and NSM are registered as CIM methods and RCI has the higher priority, then CIM uses the CIM method that uses RCI to check the node status.

If the target is a PRIMEPOWER node or a PRIMEPOWER partition, the RCI CIM method returns UP or DOWN, and then processing ends. However, if the node being checked by the RCI method is not connected to the RCI or if the RCI is not operating properly, then the RCI method will fail. CIM then uses the NSM-based CIM method to check the node state.

Similarly if MMB and NSM are registered as CIM methods and MMB has the higher priority, then CIM uses the CIM method that uses MMB to check the node status. In this case, if the target is a PRIMEQUEST node, the MMB CIM method returns UP or DOWN, and then processing ends. However, if the node being checked by the MMB method is not connected to the MMB or if the MMB is not operating properly, then the MMB method will fail. CIM then uses the NSM-based CIM method to check the node state.

The CIM reports on whether a node state in a cluster is consistent (true), or a node state is not consistent (false) for the cluster. True and false are defined as follows:

- **TRUE**—A known state for all CIM nodes
- **FALSE**—An unknown state for any cluster CIM node

Shutdown Facility

The CIM allows applications to determine when a cluster is in a consistent state, but it does not take action to resolve inconsistent clusters. Many different methods to ensure consistent clusters have been used in the high-availability field, but there is only one method that has proven completely effective and does not require cooperation between the nodes. PRIMECLUSTER uses this method known as the Shutdown Facility (SF) to return to a consistent cluster state when something occurs to disrupt that state. In the cluster partition example shown in Figure 2, both nodes will report the other node as having the state `LEFTCLUSTER`. The CIM will return a `FALSE` status. To get the cluster into a consistent state, SF forces one of the nodes into a safe state by either forcing a panic or shutting off the power.

The SF can be configured to eliminate nodes through a variety of methods. When the SF receives a request to eliminate a node, it tries to shut down the node by using the methods in the order that were specified. Once a method has successfully eliminated the node, the node's state is changed to `DOWN` by the SF.

The transition from `LEFTCLUSTER` to `DOWN` is the signal used by the various cluster services to start recovery actions. In the two-node cluster configuration in Figure 2, the first elimination method could be to panic the node through the cluster console. If this were to fail, the next method might be to use a method to turn off the power to the node. Note that different systems will support different shutdown methods. For example, the cluster console is available for Solaris, but is not available for Linux.

If all of the configured SF methods fail to return a positive acknowledgement that the requested node has been eliminated, then no further action is taken. This leaves the cluster in an inconsistent state and requires operator intervention to proceed.

This fail-safe approach ensures that damage to user data could not occur by inadvertently allowing an application to run in two parts of a partitioned cluster. This also protects from the situation where a node fails to respond to heartbeats (for example, an extreme system load) and then comes back to life later. In this case, the application on the node that returns to life may continue to run even though the other node has taken action to start that application.



PRIMECLUSTER allows you to use various hardware-specific methods to set definition that reset nodes on which Solaris or Linux operate. For example, PRIMECLUSTER allows you to forcibly stop a node by using the RCI, sending a `BREAK` signal to the console unit, using the RSB, or using the MMB.

Monitoring Agents (MA)

Many hardware platforms provide an environmental monitoring and control network that can report on the state of a system. For example, the PRIMEPOWER hardware provides the Remote Cabinet Interface (RCI) and the PRIMEQUEST hardware provides the Management Board (MMB), which were discussed previously in the Shutdown Facility as means to shutdown a system. The RCI and the MMB can also be used to monitor the state of the system and quickly detect when a node has panicked or been shutdown. Other hardware platforms use different interfaces but the functionality is similar.

PRIMECLUSTER provides a mechanism where these hardware monitors can be used to quickly detect a system state change and inform the cluster membership functions. Without this monitoring capability, only the cluster heartbeat timeout will detect that a node has panicked; this will take up to 10 seconds with the default heartbeat interval. When a Monitoring Agent (MA) is used, it can detect a node panic very quickly. For example, with PRIMEPOWER hardware and the RCI, the MA takes less than 1 second to detect a system panic. MAs are implemented as plug-ins that interfaces with the Shutdown Facility.

The MA technology allows PRIMECLUSTER to recover from monitored node failures very quickly. For non-cluster aware applications the time from when a node panic occurs to the time that the application recovery begins can be as short as 2.5 seconds under optimal conditions. The time the application takes to start up and become ready to operate varies from one application to another. For cluster-aware applications, such as Oracle RAC, the time from a system panic to the time Oracle has started recovery and is processing queries on the surviving nodes can be as short as 6.5 seconds. At this point, Oracle may still be performing some recovery actions that might impact performance, but it is able to respond to user queries.

If a node fails, PRIMECLUSTER does the following:

- Detects a node failure
- Notifies of the failure
- Confirms the node state
- Eliminates the node

The MA notifies SF of a node failure on detecting it. SF seeks a redundant confirmation regarding the node state to assess the reliability of the failure notification. This verification procedure is required to prevent the node that is normally running from being shut down.

SF confirms the node state as follows:

- Collects the node state information from all registered MAs again.
- Checks if the response to the CF heartbeat request is returned.

SF prompts the MA to eliminate the failed node when all the MAs notify SF of the node failure, and CF notifies SF of the failure in responding to the heartbeat request. When the node elimination is done, this brings the other node `DOWN`.

2.2.2.2 RMS configuration tools

To properly recover an application, RMS must know about the resources an application requires for proper operation. The configuration of the resources and the relationship between the resources can be very complex. RMS configuration tools assist in obtaining this information for RMS, and simplify the configuration process.

The configuration tool foundations (RMS Wizard Tools and PCS Wizards) capture generic information about the cluster and common application services. The RMS Wizard Kit and PCS Application Wizards are expert systems for configuring specific, complex applications such as SAP R/3 or Oracle Parallel Server (OPS) when they are to be monitored by RMS.



For information on the availability of RMS Wizard Kit and PCS Application Wizards, contact your local customer support service.

2.3 Scalability

Scalability is another benefit of PRIMECLUSTER. Scalability is provided by the cluster's ability to grow in computing capacity when demand increases. There are two basic types of applications relative to scalability. These types of applications can be divided as follows:

- Applications that interact closely with the cluster software and are designed for a distributed environment
- Applications that are not aware of the cluster

Applications that interact with cluster software

An example of a scalable application that interacts with cluster software is Oracle 9iRAC. Oracle 9iRAC starts an instance of the database server on some or all the nodes of the cluster. In addition, Oracle 9iRAC interacts with the cluster software to send messages between the instances on different nodes and must know about the state of the nodes in the cluster.

Applications that are not aware of the cluster

Applications that do not have special provisions for distributing their work in the cluster can be replicated on different nodes. If the application is designed so that different users can run separate copies of the application on a single computer, then this effect can be extended by using Scalable Internet Services (SIS) (refer to the Chapter “SIS”) to distribute the workload to the nodes of the cluster and Global File Services (GFS) to allow an application to run anywhere in the cluster (refer to the section “PRIMECLUSTER components” on page 26 and the manuals for PRIMECLUSTER GFS for more details).

3 PRIMECLUSTER architecture

This chapter explains the PRIMECLUSTER architecture and discusses the key features that PRIMECLUSTER provides.

This chapter discusses the following:

- The section “Architectural overview” on page 21 introduces the basic PRIMECLUSTER components and how the components function within the clustering environment.
- The section “PRIMECLUSTER key design features” on page 24 details the key design features of PRIMECLUSTER, including operating system and platform independence, scalability, availability, and guaranteed data integrity.
- The section “PRIMECLUSTER components” on page 26 describes the Cluster Foundation (CF), Reliant Monitor Services (RMS), Web-Based Admin View graphical user interface (GUI), and optional PRIMECLUSTER services.

3.1 Architectural overview

The PRIMECLUSTER design is based on a long history of clustering and high availability (HA) software and hardware experience. Figure 3 is a conceptual model of a typical cluster design that illustrates PRIMECLUSTER's position as a middleware solution. Features of the PRIMECLUSTER solution include:

- PRIMECLUSTER is easily ported to new hardware platforms, operating systems, and cluster interconnects.
- PRIMECLUSTER provides services only for the management or use of the cluster.
- PRIMECLUSTER supplies interfaces so that other applications, such as enterprise management software, can interact with or call on services provided by PRIMECLUSTER.

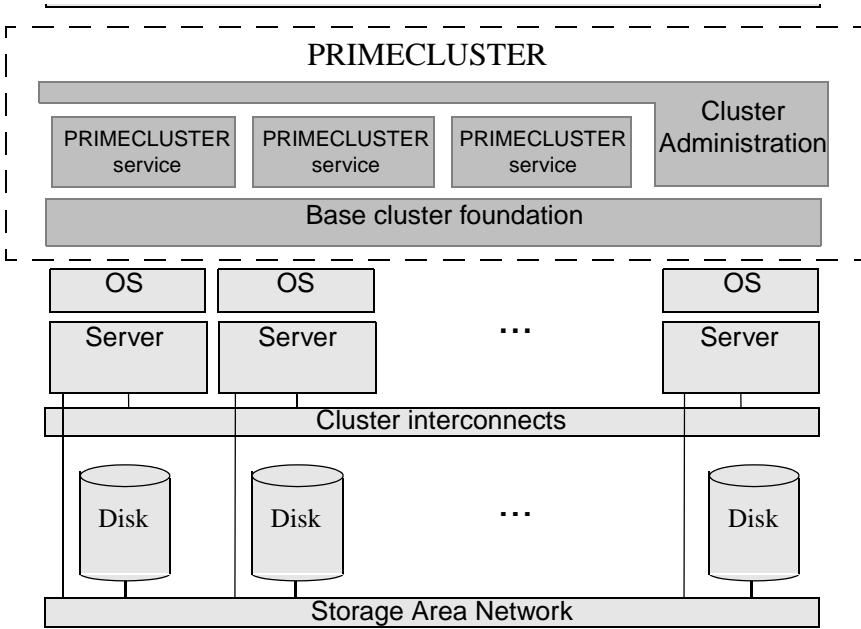

Figure 3: Diagram of a typical PRIMECLUSTER setup

Figure 4 shows a conceptual overview of the PRIMECLUSTER software architecture and how it interfaces with a server's native operating system. All of the PRIMECLUSTER software modules use operating-system-independent interfaces with an operating-system-dependant (OSD) layer to communicate between themselves and to access the base operating system services. Some examples of the operations that the OSD provides are as follows:

- Memory allocations
- Synchronizations
- Device and network access

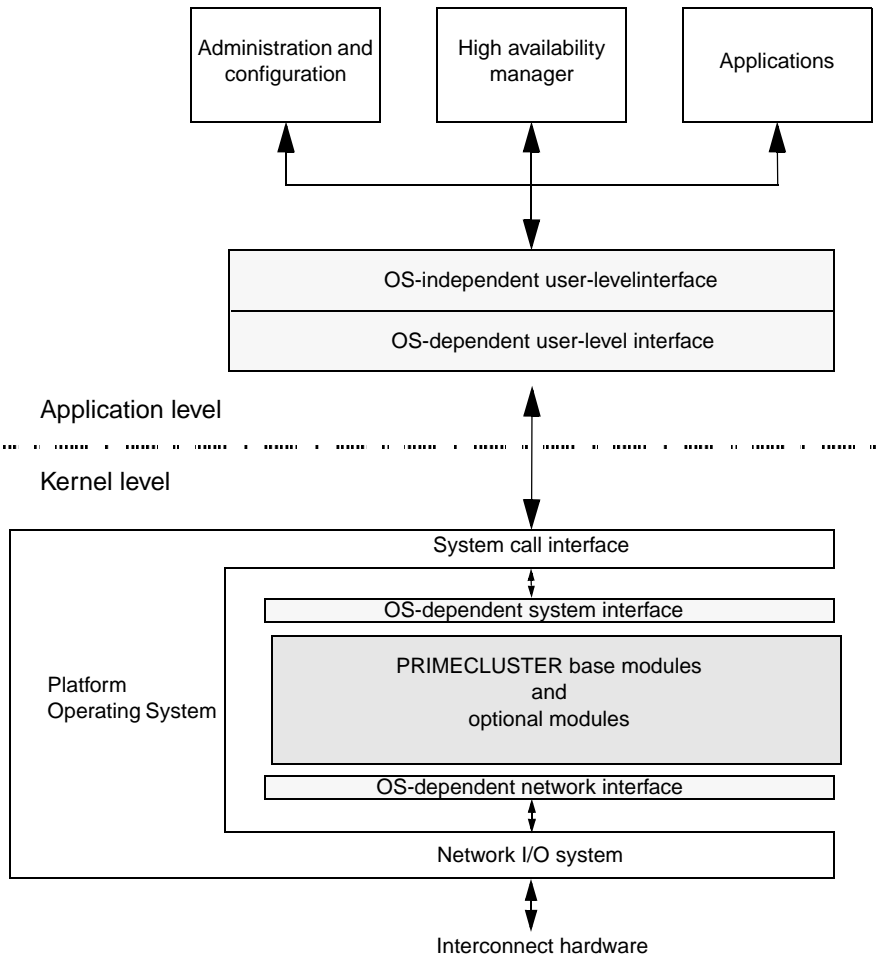

Figure 4: PRIMECLUSTER framework overview

3.2 PRIMECLUSTER key design features

The PRIMECLUSTER clustering software has been designed to satisfy the following goals:

- Modularity
- Platform independence
- Scalability
- Availability
- Guaranteed data integrity

3.2.1 Modularity

PRIMECLUSTER is composed of a core set of modules called the Cluster Foundation (CF) that provide the basic clustering functions. In addition, PRIMECLUSTER has optional modules such as the Parallel Application Services (PAS) module, the Scalable Internet Services (SIS) module, and the Reliant Monitor Services (RMS) module.

3.2.2 Platform independence

PRIMECLUSTER is independent of the operating system or hardware platform. Its modules are designed and coded based on an abstraction of an operating system's kernel functions. This is done with an OSD adaptation layer specific to different operating systems and network interconnects. This approach allows PRIMECLUSTER to plug seamlessly into the supported operating system without any modification to that operating system.

3.2.3 Scalability

PRIMECLUSTER provides not only high availability, but scalability as well. PRIMECLUSTER allows multiple nodes to act together to provide a common service. For example, with SIS, you can distribute web hits across all nodes in a cluster. With PAS, you can run a parallel database across multiple nodes. GFS provides you with a clusterwide file system so cooperating processes on many nodes can access the same data.

PRIMECLUSTER's scalability is important for customers who find that an application's demand for resources (especially CPU resources) has exceeded the capacity of a single machine. By clustering the nodes, more capacity is available for these types of applications.

3.2.4 Availability

PRIMECLUSTER implements a symmetric software architecture: All cluster information is fully replicated across nodes, thus avoiding single software points of failure. PRIMECLUSTER also supports multiple redundant interconnects, avoiding single hardware points of failure. RMS, the PRIMECLUSTER high availability manager, ensures the availability of applications by restarting or recovering applications on other nodes if there is a node failure. PRIMECLUSTER also includes an optional network load-balancing module (SIS, GLS) that can improve network availability.

3.2.5 Guaranteed data integrity

PRIMECLUSTER's algorithms guarantee that network partitions (or split-brain scenarios)— even during multiple hardware interconnect failures—do not result in data inconsistency problems. The quorum algorithms ensure that only one partial cluster can operate during a network partition.

3.3 PRIMECLUSTER components

The PRIMECLUSTER core component, Cluster Foundation (CF), provides the basic cluster services on which all other components are built. CF includes:

- Cluster Admin—Supplies the interface for cluster administration, configuration, monitoring, and diagnostics services.
- Web-Based Admin View—Provides a framework under which all the PRIMECLUSTER GUIs, including Cluster Admin, run.
- PRIMECLUSTER Simple Network Management Protocol (SNMP)—Collects and reports information and statistics on the status and configuration of PRIMECLUSTER modules.

The optional components and products are as follows:

- Reliant Monitor Services (RMS)—Manages high-availability switchover (failover) of application processes and their resources.
- RMS Wizard Tools and PRIMECLUSTER Configuration Services (PCS) Wizards—RMS configuration tool foundations.

RMS Wizard Tools and PRIMECLUSTER Configuration Services (PCS) Wizards are mutually exclusive with respect to installation and operation.

- RMS Wizard Kit and PCS Application Wizards—Each RMS Wizard Kit or PCS Application Wizard configures RMS for a specific enterprise application.

RMS Wizard Kit and PCS Application Wizards are mutually exclusive with respect to installation and operation. The RMS Wizard Kit works with the RMS Wizard Tools, and the PCS Application Wizards work with the PCS Wizards (see Figure 20).

- Parallel Application Services (PAS)—Provides a high-performance, low-latency communication facility that can be used by applications.
- Scalable Internet Services (SIS)—Performs network load balancing and provides a highly available interface to the cluster.
- Global Disk Services (GDS)—Provides the volume management component that improves the availability and manageability of disk-stored data.

- Global File Services (GFS)—Provides a file system that can be accessed from two or more nodes to which a shared disk unit is connected.
- Global Link Services (GLS)—Enables high reliability communications through the use of multiple network interface cards to create multiple redundant paths to a local system.

3.3.1 CF

The Cluster Foundation is the base on which all the other modules are built. It provides the fundamental services, such as the OSD, that all other PRIMECLUSTER components use as well as the base cluster services.

CF has the following features:

- Contains a loadable pseudo device driver that automatically loads when the system starts
- Supplies the CF driver that contains the CF kernel-level OSD and generic modules

Some of the functions that CF provides are detailed in the sections that follow.

3.3.1.1 OSD

The CF operating-system-dependant (OSD) module provides an interface between the native OS and the abstract, OS-independent interface upon which all PRIMECLUSTER modules depend. This allows PRIMECLUSTER to use the same source files for all supported operating systems and architectures. The two main advantages of this design are as follows:

- Only need to maintain one version of the source
- Simplifies the porting of CF to a new operating system or architecture

3.3.1.2 ICF

The Internode Communication Facility (ICF) module is the network transport layer for all PRIMECLUSTER inter-node communications. It provides the following functions:

- Ordered, guaranteed, node-to-node datagram communication services
- Guarantees to deliver messages to the destination node in the queued for transmission order, unless the destination node fails
- Interfaces via OS-dependent code to the Network I/O sub-system

To avoid a single point of hardware failure, ICF supports multiple interconnects. When multiple interconnects are available, ICF spreads messages across all available interconnects to improve performance. ICF automatically switches between interconnects when a failure occurs. ICF has a route recovery mechanism for transient interconnect failures such as a network switch being powered off and on again.

ICF is only usable by the CF internal components and is not available to user-level resources. To provide applications with an access to the cluster interconnect, Cluster Interconnect Protocol (CIP) is used. CIP provides a standard TCP/IP protocol suite over ICF.

3.3.1.3 JOIN

The cluster join services module (JOIN) dynamically joins a node to a cluster. If the cluster does not exist, then CF creates it. It is possible for several nodes to simultaneously try to form a cluster. The mastering algorithm solves this problem by using a distributed-election algorithm to determine which node should become master and form the cluster. Each node has equal rank, and each node can form the initial one-node cluster.

After the initial cluster is formed, all other nodes can join it. JOIN has built-in support for rolling upgrades by providing versioning information during the initial mastering phase. A new node joining the cluster automatically selects the protocol version in use by the current cluster.

3.3.1.4 ENS

The Event Notification Services (ENS) module provides an atomic-broadcast facility for events. Messages queued to ENS are guaranteed to either be delivered to all of the nodes or to none of the nodes. PRIMECLUSTER modules and application programs can both use ENS. Applications can register with ENS to receive notification of cluster events such as nodes joining or leaving the cluster. Applications can also define and broadcast application-specific events to other applications that register for it.

3.3.1.5 Cluster Admin

The Cluster Admin manager is an administrative interface for the following cluster features:

- Configuration
- Administration
- Operations and diagnostics services

Administration can be done from any node in the cluster, remotely from the Internet, or from both. A Java-enabled Web browser serves as the administrative interface; a conventional command-line interface is also available on a node. Diverse, clear-reporting metrics and event logs provide concise and timely information on the state of the cluster.

3.3.1.6 Web-Based Admin View

Web-Based Admin View is a GUI framework used by the PRIMECLUSTER products. The features of Web-Based Admin View are as follows:

- Common framework for multiple GUIs
In addition to the Cluster Admin GUI, which controls CF, SIS, RMS, and SF, PRIMECLUSTER contains GUIs for other services such as GDS and GFS. In the Web-Based Admin View, all of these GUIs operate as a common framework.
- A single login for multiple GUIs.
- Password encryption. Passwords sent from the client browser to the management server are encrypted.
- Logging of all GUI commands dealing with configuration or administration.

- The ability to off load the management overhead onto the management servers outside the cluster.



For additional information about Web-Based Admin View features, see your *Web-Based Admin View Operation Guide*.

3.3.1.7 SNMP

The PRIMECLUSTER SNMP collects and reports information and statistics on the status and configuration of PRIMECLUSTER modules. The information can be queried by any SNMP management station. The PRIMECLUSTER modules that currently display information by means of SNMP are as follows:

- Cluster Foundation (CF)
- Reliant Monitor Services (RMS)

The PRIMECLUSTER SNMP consists primarily of MIBs (Management Information Bases) and subagents. MIBs are files that define what information will be provided via SNMP. The subagents are the programs that query PRIMECLUSTER components and display the information.

3.3.1.8 PRIMECLUSTER SF

The PRIMECLUSTER Shutdown Facility (SF) provides an interface to guarantee machine shutdown during error processing within the cluster. PRIMECLUSTER SF is made up of the following major components:

- Shutdown Daemon (SD)—The SD monitors the state of cluster machines and provides an interface for gathering status and requesting manual machine shutdown.
- One or more Shutdown Agents (SA)—The SA's role is to guarantee the shutdown of a remote cluster node.
- MA (asynchronous monitoring)—In addition to the SA, the MA monitors the state of remote cluster nodes and immediately detects failures in those nodes.

The advantages of PRIMECLUSTER Shutdown Facility are as follows:

- Ability to shut down a cluster node with or without running RMS
- Ability to shut down a cluster node from any PRIMECLUSTER service-layer product
- Redundant shutdown methods are available

Monitoring Agent

The Monitoring Agent (MA) has the capability to monitor the state of a system and promptly detect a failure such as system panic and shutdown. This function is provided by taking advantage of the hardware features that detect the state transition and inform the upper-level modules.

Without the MA, the cluster heartbeat time-out detects only a communication failure during periodic intervals. The MA allows the PRIMECLUSTER system to quickly detect a node failure.

The MA provides the following functions:

- Monitors the remote node state—The MA monitors the state of the remote node that uses the hardware features. It also notifies the Shutdown Facility (SF) of a failure in the event of an unexpected system panic and shutoff. Even when a request of responding to heartbeat is temporarily disconnected between cluster nodes because of an overloaded system, the MA recognizes the correct node state.
- Eliminates the remote node—The MA provides a function to forcibly shut down the node as Shutdown Agent (SA).

The hardware products supported by the MA are as follows:

- RCI—The MA monitors the node state and detects a node failure by using the SCF/RCI mounted on a PRIMEPOWER platform. The System Control Facility (SCF), which is implemented on a hardware platform, monitors the hardware state and notifies the upper-level modules. The MA assures node elimination and prevents access to the shared disk.



Node state monitoring of the RCI asynchronous monitoring function operates from when message (a) shown below is output until message (b) is output. The messages for the console asynchronous monitoring function are messages (c) and (d). When node state monitoring is disabled, the function that forcibly stops nodes may not operate normally. The messages for the MMB asynchronous monitoring function are messages (e) and (f).

- (a) `FJSVcluster:INFO:DEV:3042: The RCI monitoring agent has been started.`
 - (b) `FJSVcluster:INFO:DEV:3043: The RCI monitoring agent has been stopped.`
 - (c) `FJSVcluster:INFO:DEV:3040: The console monitoring agent has been started (node:monitored node name).`
 - (d) `FJSVcluster:INFO:DEV:3041: The console monitoring agent has been stopped (node:monitored node name).`
 - (e) `FJSVcluster:INFO:DEV:3080: The MMB monitoring agent has been started.`
 - (f) `FJSVcluster:INFO:DEV:3081: The MMB monitoring agent has been stopped.`
- **RCCU**—(Not available on all PRIMECLUSTER systems.) The console monitoring agent monitors message output to the console of each node. If an error message of a node failure is output to one node, the other node detects the message and notifies SF of a node failure. Normally, the console monitoring agent creates a loop, monitoring another node, for example, A controls B, B controls C, and C controls A. If one node goes down because of a failure, another node takes over the monitoring role instead of this failed node.

The console monitoring agent also ensures node elimination by sending a break signal to the failed node.

Figure 5 shows how the monitoring feature is taken over in a cluster system with three nodes if one node goes down. The dotted line indicates that a node monitors another node.

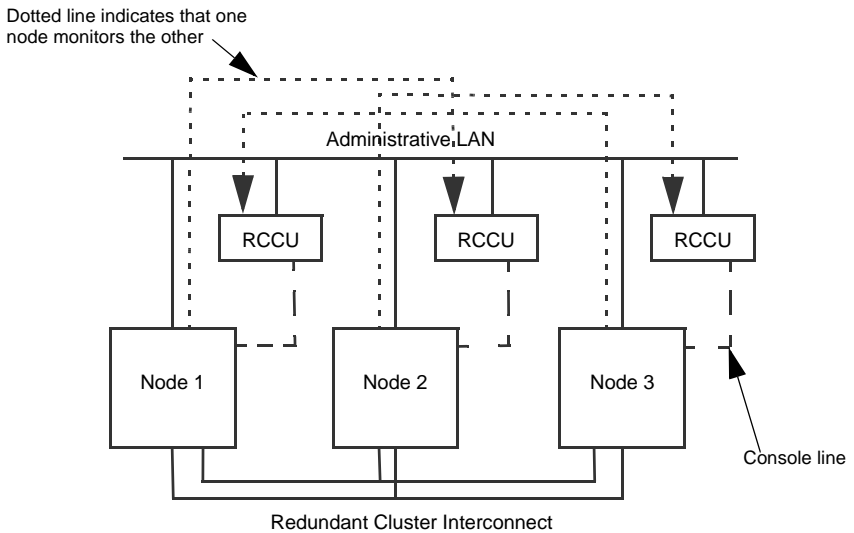

Figure 5: MA normal operation

When a failure occurs, and Node 2 is DOWN, the following actions occur:

- Node 1 begins to monitor Node 3.
- The following message is output to the `/var/adm/messages` file of Node 1:

```
FJSVcluster:Information:DEV:3044: The console monitoring agent took over monitoring (node: targetnode)
```

Figure 6 shows how Node 1 added Node 3 as the monitored node when Node 2 went down.

Node 1 added Node 3 as the monitored node.

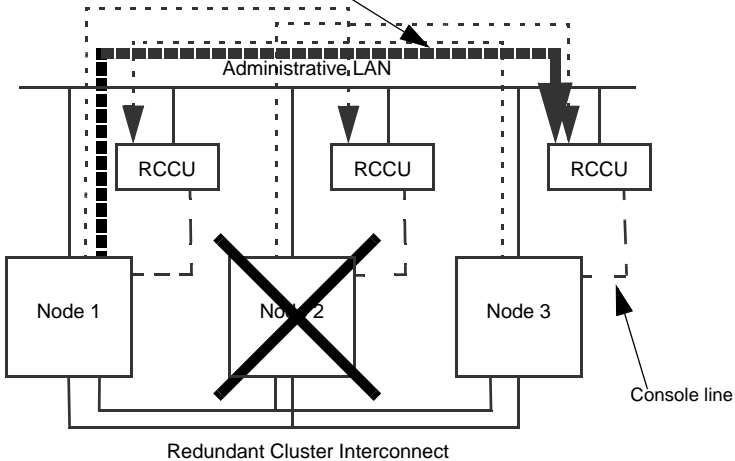

Figure 6: MA operation in the event of node failure

When Node 2 recovers from the failure and starts, the following actions occur:

- The original monitoring mode is restored.
- The following message is output to the `/var/adm/messages` file of Node 1:

```
FJSVcluster:Information:DEV:3045: The console monitoring agent cancelled to monitor (node: targetnode)
```

Figure 7 shows how Node 2 returns to monitoring Node 3 once it has been restored to the cluster.

Node 2 has been restored to monitoring Node 3

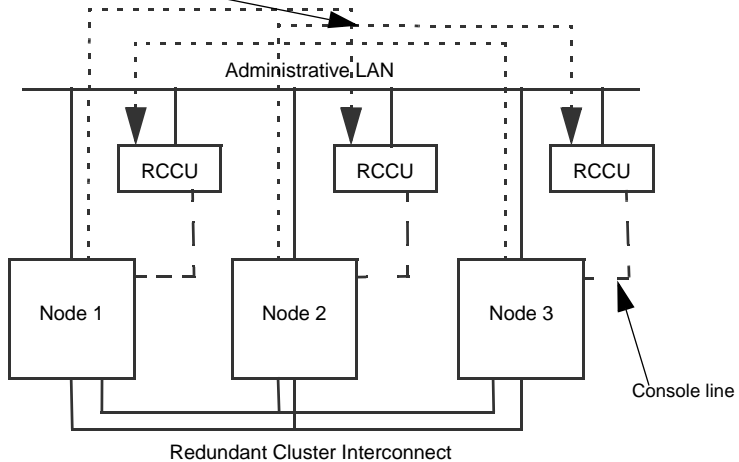

Figure 7: Node recovery

The following are possible messages that might be found in the `/var/adm/messages` file:

- `FJSVcluster:Information:DEV:3042: The RCI monitoring agent has been started`
Indicates that the RCI monitoring agent is enabled.
- `FJSVcluster:Information:DEV:3043: The RCI monitoring agent has been stopped`
Indicates that the monitoring feature is disabled.
- `FJSVcluster:Information:DEV:3040: The console monitoring agent has been started (node:monitored node name)`
Indicates that the monitoring feature of the console monitoring agent is enabled.
- `FJSVcluster:Information:DEV:3041: The console monitoring agent has been stopped (node:monitored node name)`

Indicates that the monitoring feature of the console monitoring agent is disabled. When the monitoring feature is not enabled, the other feature that forcibly brings the node DOWN might not work.



The console monitoring agent monitors the console message of the remote node. So it cannot recognize the node state in the event of an unexpected shutdown. In such a case, the node goes into the LEFTCLUSTER state, and you need to mark the remote node DOWN.

- MMB asynchronous monitoring (MMB) (PRIMEQUEST)

This function uses the MMB, which is one of the hardware units installed in PRIMEQUEST, to monitor nodes. The function can ascertain node failures by having the MMB, which is one of the standard units installed in the hardware, report the node state to the software.

This function can intentionally trigger a panic or a reset in other nodes to forcibly stop those nodes with certainty and prevent contention over user resources.



- If a node error occurs while an MMB error has occurred, it may take longer than usual for the node failure to be ascertained (up to 6 seconds).
- If a node error occurs while an error has occurred in one of the MMB management LAN systems in all nodes, it may take longer than usual for the node failure to be ascertained (up to 6 seconds).
- It may take up to 10 minutes for an MMB error to be detected.
- If the MMB is recovered from an error, it takes up to 10 minutes for that recovery to be detected. However, if a node error occurs before the recovery is detected, the recovery is recognized at that point, and the MMB asynchronous function actually operates without any problems. To have an MMB recovery detected immediately after the MMB is recovered from an error, restart the Shutdown Facility (SF).
- If an error (`snmptrapd` is stopped) occurs in the local node, the following message is displayed:

```
FJSVcluster:INFO:DEV:3084:Monitoring another node has been stopped.
```

In this case, node state monitoring is disabled. Therefore if a node error occurs under this condition, it may take longer than usual for the node failure to be ascertained.

Also after a node is started or after the Shutdown Facility is restarted, node state monitoring is disabled even if the following message is not displayed. Therefore if a node error occurs under this condition, it may take longer than usual for the node failure to be ascertained.

```
FJSVcluster:INFO:DEV:3083:Monitoring another node has been started.
```

- The following message may be displayed while a node is being started:

```
FJSVcluster: INFO: DEV: 3084: Monitoring another node has been stopped.
```

This condition occurs because `snmptrapd` is being started, and there is not problem as long as the following message is output within about 10 minutes after `snmptrapd` is started:

```
FJSVcluster: INFO: DEV: 3083: Monitoring another node has been started.
```

- If you execute `sdtool -s` immediately after the node is started, Test Failed may be displayed as the test state of the local node. To check the test state of the local node immediately after the node is started, execute `sdtool -r` and then execute `sdtool -s`.



The MMB asynchronous monitoring function displays the following messages if the MMB management LAN is disconnected:

```
FJSVcluster:WARN:DEV:5021:An error has been detected in part of the transmissionroute to MMB. (node:nodename mmb_ipaddress1:mmb_ipaddress1 mmb_ipaddress2:mmb_ipaddress2 node_ipaddress1:node_ipaddress1 node_ipaddress2:node_ipaddress2)
```

```
FJSVcluster:ERROR:DEV:7213:An error has been detected in the transmission route to MMB. (node:nodename mmb_ipaddress1:mmb_ipaddress1 mmb_ipaddress2:mmb_ipaddress2 node_ipaddress1:node_ipaddress1 node_ipaddress2:node_ipaddress2)
```

Respond according to the action for each message. If error message 7213 is displayed, node state monitoring is disabled. Therefore the function that forcibly stops other nodes may not operate normally. In addition, if an error (for example, `snmptrapd` terminates abnormally) occurs in the local node, the following message is displayed:

```
FJSVcluster:ERROR:DEV:7210:An error was detected in MMB.  
(node:nodename mmb_ipaddress1:mmb_ipaddress1  
mmb_ipaddress2:mmb_ipaddress2  
node_ipaddress1:node_ipaddress1  
node_ipaddress2:node_ipaddress2 status:status detail:detail)
```

In this case as well, node state monitoring is disabled. Therefore the function that forcibly stops other nodes may not operate normally. For details about this message, see "Monitoring Agent messages" in the PRIMECLUSTER *Cluster Foundation Configuration and Administration Guide*.

Shutdown Agents (SA)

The PRIMECLUSTER Shutdown Facility provides the following Shutdown Agents:

- RCI (SA_pprcip, SA_pprcir): Remote Cabinet Interface
This SA uses the RCI, which is one of the hardware units installed in PRIME-POWER, to stop other nodes with certainty by intentionally triggering a panic or reset in those nodes.
- RCCU (SA_rccu): Remote Control Connection Unit
This SA uses the Remote Control Connection Unit, which is connected to other nodes, and stops other nodes with certainty by sending the break signal to those nodes.
- XSCF (SA_xscfp, SA_xscfr, SA_rccu): eXtended System Control Facility
The SA uses the XSCF, which is one of the hardware units installed in PRIMEPOWER, to forcibly stop other nodes with certainty by intentionally triggering a panic or reset in those nodes.
If the XSCF is being used in the console, the Shutdown Facility stops other nodes with certainty by sending the break signal to those nodes.
- NPS (SA_wtinps): Network Power Switch (not supported)
The SA uses the Western Telematic Inc.'s Network Power Switch (WTINPS) to stop other nodes with certainty by shutting them down.
- RPS (SA_rps): Remote Power Switch (not supported)
This SA uses the Remote Power Switch (RPS) unit to stop other nodes with certainty by shutting them down.

- **RSB (SA_rsb): RemoteView Service Board**

This SA uses the RemoteView Service Board (RSB) to stop other nodes with certainty by shutting them down.
- **BLADE (SA_blade)**

This SA, which can be used in the PRIMERGY blade server, uses the SNMP command to stop other nodes with certainty by shutting them down.
- **IPMI (SA_ipmi). Intelligent Platform Management Interface**

This SA uses the IPMI, which is one of the hardware units installed in PRIMERGY, to stop other nodes with certainty by shutting them down.
- **MMB (SA_mmbp, SA_mmbnr): Management Board**

This SA uses the MMB, which is one of the hardware units installed in PRIMEQUEST, to forcibly stop other nodes with certainty by intentionally triggering a panic or reset in those nodes.
- **netdump (SA_1kcd)**

If the other node panics, this SA executes high-speed cluster switchover when netdump is used to collect a crash dump.
- **diskdump (SA_1kcd)**

If the other node panics, this SA executes high-speed cluster switchover when diskdump is used to collect a crash dump.

3.3.1.9 SCON



This section applies only to Solaris platforms.

In PRIMECLUSTER, a cluster console can be used to replace the consoles for standalone systems. This cluster console provides a single point of control for all cluster nodes. In addition to providing administrative access, a cluster console runs the SMAWRscon software which performs node elimination tasks when required.

In most installations of PRIMECLUSTER, a single cluster console can be used, but in some instances, you must configure multiple cluster consoles to provide adequate administrative access to cluster nodes.

The instances where multiple cluster consoles are needed are as follows:

- When using two or more PRIMEPOWER 800, 900, 1000, 1500, 2000, or 2500 systems that do not share a common system management console.
- Where the nodes are so far apart that it would be unreasonable for them to share a common cluster console. This may be the case when the cluster nodes are used to provide disaster recovery capabilities.

When two or more cluster consoles are used in a cluster, it is called a distributed cluster console configuration.

The cluster console attaches to the console serial ports for systems such as the PRIMEPOWER models 100 through 850 that do not support hardware partitioning by means of a serial-line-to-network converter unit (CU). The CU can be one of several types supported in PRIMEPOWER clusters such as the Remote Console Access (RCA), Remote Console Connection Unit (RCCU), or Multipoint Console Connection Unit (MCCU). For systems that support hardware partitioning, such as the PRIMEPOWER models 800, 1000 – 2500, the cluster console interfaces to the System Management Console to selectively control each partition.

Single cluster console

A single cluster console configuration is one in which the console lines for all cluster nodes are accessible from one central cluster console (see Figure 8). Note that each CU in Figure 8 represents a generic conversion unit which is responsible for converting serial-line to network access and represents either the RCA, RCCU, or MCCU units.

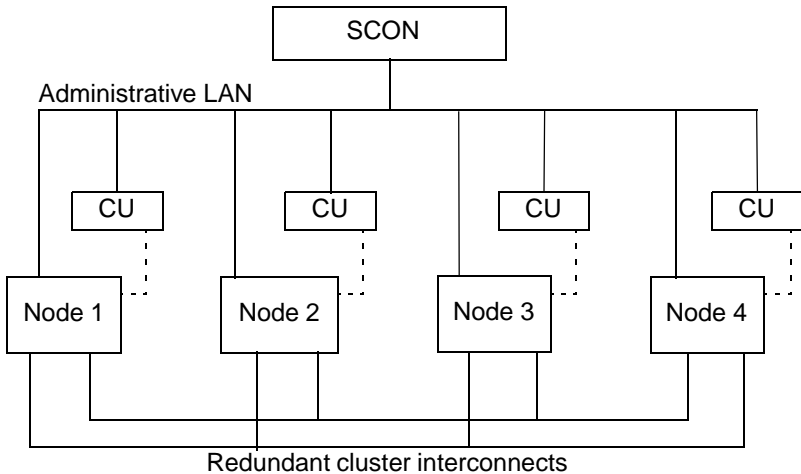

----- Console lines

Figure 8: Single cluster console configuration

The single cluster console runs the SMAWRscon software and is responsible for node elimination for all nodes in the cluster. In this configuration, all cluster nodes are known to the single cluster console, and at runtime, all cluster nodes forward shutdown requests to this console.

Distributed cluster console

A distributed cluster console configuration is a cluster with more than one cluster console. Each of these cluster consoles has access to a selected subset of the console lines for the cluster nodes (see Figure 9). The console line for each cluster node can only be accessed by one cluster console. Note that the CU in Figure 9 represents a generic conversion unit, which is responsible for converting serial-line to network access and represents either the RCA, RCCU, or MCCU units.

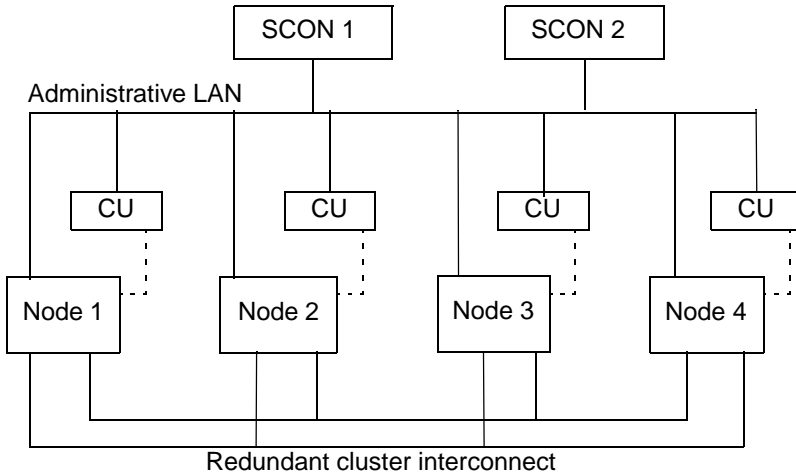

----- Console lines

Figure 9: Distributed cluster console configuration

In Figure 9, SCON 1 controls access to Node 1 and Node 2, and SCON 2 controls access to Node 3 and Node 4. When configuring the SMAWRscon product on SCON 1, only Node 1 and Node 2 will be known by it. Similarly on SCON 2, the SMAWRscon product will only know of Node 3 and Node 4.

At runtime, all shutdown requests are sent to all cluster consoles and the cluster console responsible for the node being shutdown responds to the request.

Network considerations

You must consider the following while configuring the network for both single cluster console and distributed cluster console configurations:

- Do not connect cluster consoles on the cluster interconnect
- Connect all CUs, cluster consoles, and cluster nodes to the administrative LAN
- Keep the administrative LAN physically separate from all public networks

3.3.2 RMS

RMS is an application availability manager that ensures the availability of both hardware and software resources in a cluster. This is accomplished through redundancy and through the ability to fail over monitored resources to surviving nodes.

Monitored resources can be almost any system component, such as the following:

- File system
- Volume (disk)
- Application
- Network interface
- Entire node

For redundancy, RMS uses multiple nodes in the cluster. Each node is configured to assume the resource load from any other node. In addition, RAID hardware and/or RAID software replicate data stored on secondary storage devices.

For application availability, RMS monitors resources with detector programs. When a resource fails, RMS triggers a user-defined response. Normally, the response is to make the resource available on other nodes.

Resources that are mutually dependent can be combined into logical groups such that the failure of any single resource in the group triggers a response for the entire group. During switchover, RMS ensures that all of a group's resources on the original node (before the failure) are brought offline prior to any resources being brought online on the new node. This prevents any possibility of data corruption by two or more nodes attempting to access a resource simultaneously.

Figure 10 shows how RMS uses detectors to monitor resources. A detector reports any changes in the state of a resource to the RMS base monitor, which then determines if any action is required.

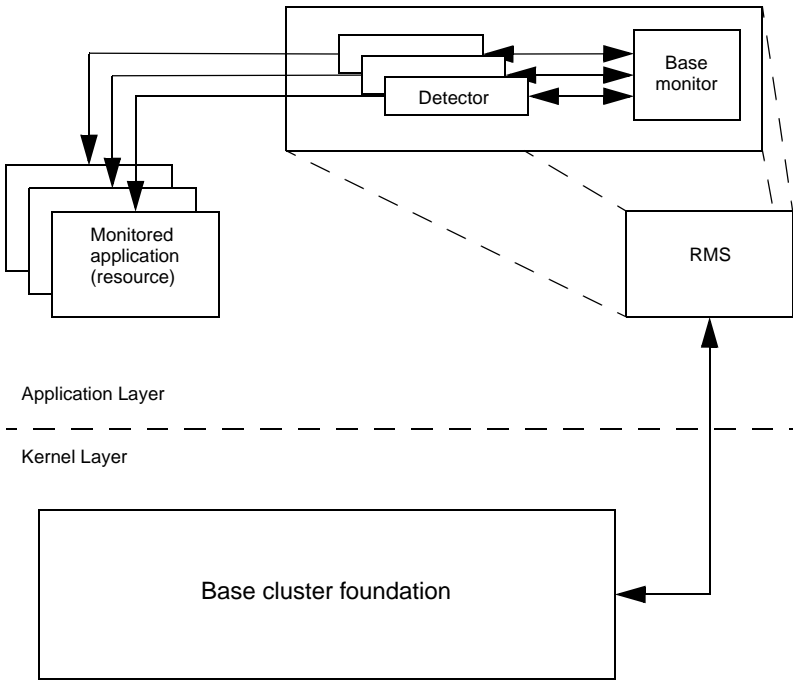

Figure 10: RMS resource monitoring

3.3.2.1 RMS configuration tools

RMS configuration tools facilitate the creation of RMS configurations and are divided into the following product areas:

- **RMS Wizard Tools and PRIMECLUSTER Configuration Services (PCS) Wizards**—These contain configuration tool foundations and interface with the RMS base. They simplify the configuration setup and work with RMS in the HA (high availability) cluster environment.
- **RMS Wizard Kit and PCS Application Wizards**—RMS Wizard Kit and PCS Application Wizards are separately distributed software options for creating optimized HA environments for individual enterprise user applications. They layer on corresponding configuration tool foundations. (Using an RMS Wizard Kit requires the RMS Wizard Tools foundation. Using a PCS Application Wizards requires the PCS Wizards foundation.)

3.3.3 SIS

SIS enables PRIMECLUSTER to act as a scalable, reliable, and easily managed network system by providing the following:

- Access through one or more Virtual Interface Provider (VIP) addresses, which appear to clients as a single network server
- Makes the cluster appear to clients as a single network server
- Provides transparent communication with the cluster by disguising the fact that the network request is serviced by one of the nodes in the cluster

Example:

Figure 11 is an example of a four-node SIS cluster. In this case, the SIS cluster is serving Web pages. The SIS cluster has one virtual address, `www.mycluster.com`, and when a client connects to this address, the Web pages are served by any of the available nodes.

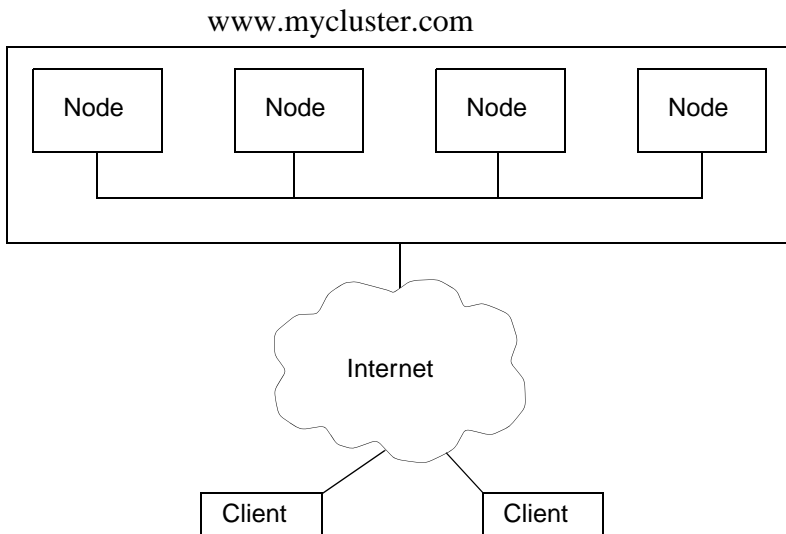

Figure 11: Example of a SIS cluster

3.3.4 PAS

Parallel database applications were one of the first commercial applications to use cluster technology. By partitioning the workload and data across multiple nodes in a cluster, parallel database applications can achieve performance beyond the limits of a single, large multiprocessor server.

The OPS (Oracle Parallel Server) has been the leader in parallel database applications since it was first deployed on commercial UNIX platforms in the early 90s. The Oracle 9iRAC and Oracle 10g *Cache Fusion* technology, which take advantage of the high-speed, interprocess communication API that PRIMECLUSTER provides, now overcomes the performance bottleneck of previous OPS implementations (that is, where database instances communicated through a secondary storage system).

3.3.5 GDS

Global Disk Services (GDS) is a volume management software that improves the availability and manageability of disk-stored data. GDS protects data from hardware failures and operational mistakes, and supports the management of disk units.

GDS has following functions, which are closely related:

- To improve availability of disk data
- To improve manageability of disk data

GDS's mirroring function protects data from hardware failures by maintaining replicas of disk data on multiple disks. This allows users to continue to access the disk data without stopping the application in the event of an unexpected trouble.

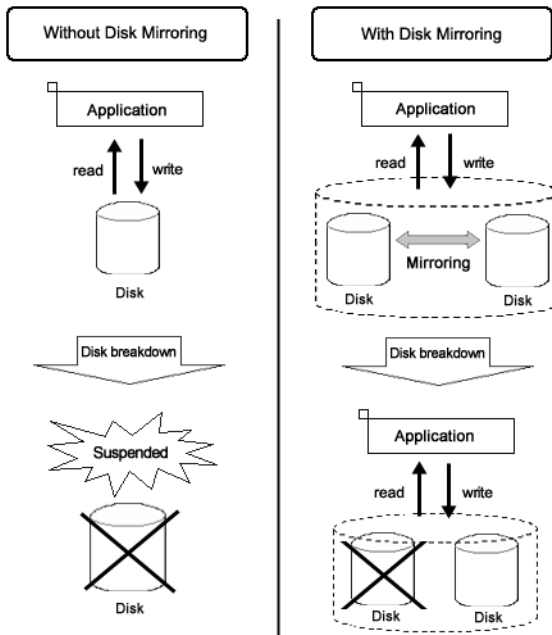

Figure 12: Disk Mirroring

The GDS management functions reduce the system administrator's workloads of disk management. The user-friendly functions simplify management, and at the same time, prevent data corruption by operational mistakes.

In a SAN (Storage Area Network) environment, multiple servers can be connected to multiple disk units (see Figure 13). Disk-stored data can be accessed from those servers. This allows simultaneous access to a file system or database and improves the efficiency of data duplication between the servers and backup procedures. On the other hand, it also carries the risk of data damage, as multiple servers will compete to access the shared disk. Therefore, volume management functions suitable for the SAN environment are essential.

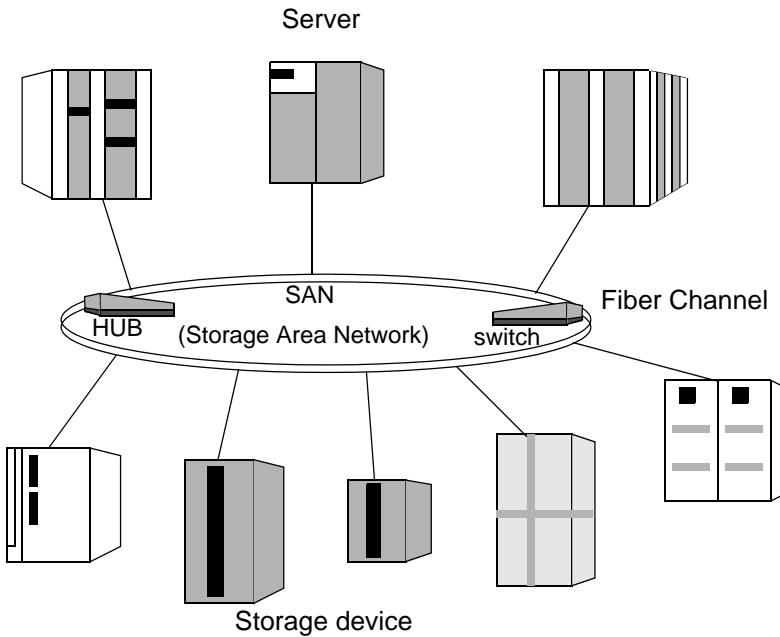

Figure 13: SAN (Storage Area Network)

GDS provides volume management functions suitable for SAN environments. GDS allows users to integrate management of all disk units connected to all servers, including local disk units that are connected to specific servers as well as disk units that are shared by multiple servers in a SAN environment.



PRIMERGY cannot manage system disks. In addition, if the Linux kernel is Version 2.4, PRIMERGY cannot manage locally connected disks.

GDS's main functions include:

- Mirroring of system disks (Solaris server and PRIMEQUEST)
- Mirroring of shared disks
- Mirroring of disk array units
- Hot spare that automatically recovers mirroring in the event of a disk failure
- Hot swap that replaces a failed disk without stopping applications

- JRM (Just Resynchronization Mechanism) that pursues high-speed recovery of mirroring in the event of an unexpected system down or cluster failover
- Integrated management and access control of disks in a SAN environment
- Automatic configuration that recognizes physical connections to servers and disk units, registers the configuration information, and checks the connections (Solaris server only)
- Concatenation that enables creation of large volumes of data
- Striping that distributes load of access to disks
- Logical partitioning that enables flexible use of disks
- Snap-shot that supports backup minimizing the effect on core services

See PRIMECLUSTER *Global Disk Services Configuration and Administration Guide* for further details.

3.3.6 GFS

The two types of GFS file system are local and shared. The GFS local file system (Solaris only) is used within one node. The GFS shared file system allows users to select optimal file system in accordance with the intended use.

3.3.6.1 GFS Local file system (Solaris only)

The GFS local file system expands UFS, the representative file system of UNIX, and improves availability and performance. The GFS local file system provides the following features:

- Logical partitioning allows a file system to be partitioned into multiple logical slices
- High-speed recovery of a file system (equivalent to UFS logging)
- Serial block allocation on an extent basis
- Easy expansion of file system area
- Area reallocation in the event of a disk block failure
- Setup of extent attributes to a file
- Defragment

The GFS local file system provides high-speed failover of a file system in the event of a node down in standby operation, using the recovery functions of data integrity. In addition, data area and defragment functions are enabled without stopping operation services. The GFS local file system is independently used, or it is used as a failover file system by RMS.

3.3.6.2 GFS shared file system

Global File Services (GFS) is a highly reliable file system, assuring simultaneous access from multiple nodes to which a shared disk unit is connected (up to 2 nodes for Linux).

GFS provides the following features:

- Simultaneous shared access to a file or file system from two or more nodes
- Data consistency and integrity when file data is referenced or updated by two or more nodes
- When a node is down, file operation can be continued on the other node while maintaining the consistency of the file system
- File system high-speed recovery function
- High-speed input/output (I/O) processing with sequential block assignment of file area
- File access using file cache of each node
- Multi-volume supports the distribution of input/output processing load and the use of large-scale file systems (Solaris only)
- Addition of online volume (area extension) is possible without disrupting or reconfiguring the file system (Solaris only)
- Creation, deletion, expansion, and operation of the file system can be performed using a GUI based Web browser interface

Simultaneous shared access while maintaining consistency

The GFS shared file system assures integrity of data when data is updated from multiple nodes. In the Solaris version, the file-lock function is enabled on multiple nodes using a conventional UFS API. When a distributed application is executed on multiple nodes, the conventional APIs are used ensuring application data transfer.

High availability

When the GFS file system is used from multiple nodes, file access can be continued from the other node even if a node is down. The file system information retained by the downed node automatically restores the consistency within the GFS on the other nodes. That is, the application program running on the other nodes can continue processing without causing an error in the file system operation.

The operations required to change file system structure (such as file creation or deletion) are recorded in the area called the update log with the GFS file system. By using the information stored in this area, a system failure can be recovered in seconds without having to make a full check of the file system structure.

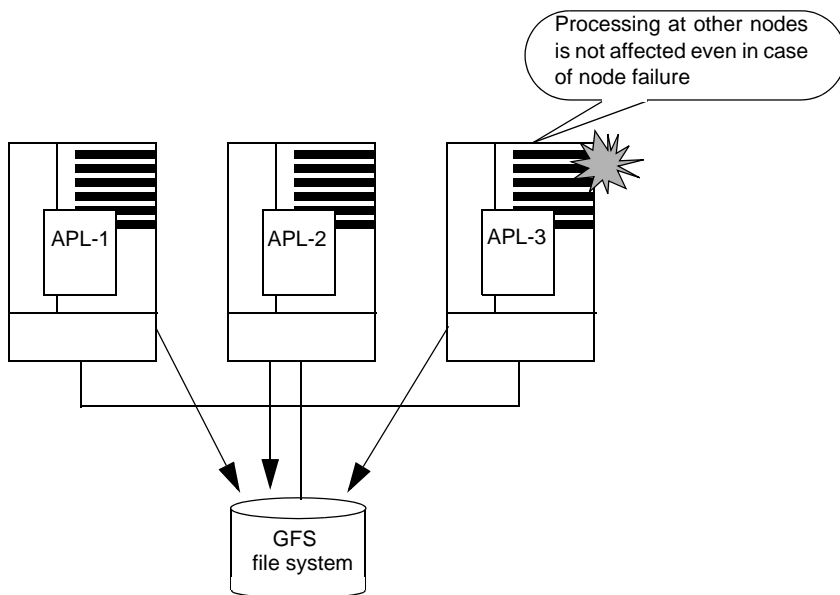

Figure 14: Operation continuation when a node is down

Data accessibility performance

GFS enables a file system on a shared disk unit to be accessed from two or more nodes. With a conventional distributed file system, data is transferred to the client that requested access from the server on which file system data is managed by means of network communication over a LAN. The requested node directly accesses the disk unit. This reduces the network load from NFS and speeds up the response time required to read or write the request.

By allocating sequential blocks to the file data, the GFS file system enables collective I/O processing to improve the file system performance.

The Solaris GFS provides a feature that integrates multiple partitions into one file system. In the case a configuration with multiple partitions, the round-robin allocation method is used, so the file data area can be used from different partitions for each file. Therefore, the I/O load can be distributed into multiple disk units and the file system performance is improved. This function makes it easy to add the data partition described afterwards.

Scalability (Solaris only)

With the GFS file system, the file system can be easily expanded by specifying an empty disk partition. Thus, a shortage of free space in a file system can be solved in a short time. A data partition can be added even while mounting.

3.3.6.3 Benefits

GFS has the following benefits:

- The use of file cache on each system and high speed data access not using the LAN improve access performance.
- CPU load distribution of application is enabled via files on two or more systems assuring data integrity.
- A high availability system is provided by continuing file access on other node when the current node goes down.
- Area management on extent base and multi-volume (*1) support provides high-speed file access. (*1: multi volume is supported in Solaris only.)
- Multi-volume supports the use of large-scale file systems and addition of online volume (area extension) are enabled without disrupting or reconfiguring the file system, and it makes the resource management easy. (Solaris only)

- Operation of the file system using a GUI based Web browser interface eases environment configuration and management.

3.3.7 GLS

Global Link Services (GLS) is a software product that enables high reliability communications through the use of multiple network interface cards (NICs) to create redundant multiple transmission paths to a local system. Global Link Services provides network solutions that are suitable for systems in which communications continuity is important.

The benefits of Global Link Services are as follows:

- Multiple NICs can provide redundant transmission paths to offer high availability and path failure protection.
- The use of GLS means that applications can continue to run even in the event of changes in the LAN configuration, the redundant transfer route, or any network fault that may occur in a transfer route.

When using PRIMECLUSTER, you can choose the following mode for dual transfer routes: NIC switching mode - Creates a transfer route between a Switch/HUB and servers on the same network.

For details on the features of Global Link Services, see the PRIMECLUSTER *Global Link Services Configuration and Administration Guide: Redundant Line Control Function*. and *PRIMECLUSTER Global Link Services Configuration and Administration Guide: Multipath Function*.

NIC switching mode

In NIC switching mode, duplexed NICs (LAN cards) are connected on the same network and switching of the transfer route is controlled using the NIC. There are no restrictions on the devices that can be connected, and it is possible to communicate with hosts on another network. To duplex the entire communication route, it is also necessary to duplicate the network equipment, such as routers, on the transfer routes and on all hosts because the duplexing of the paths should extend up to the direct connections to switches and HUBs.

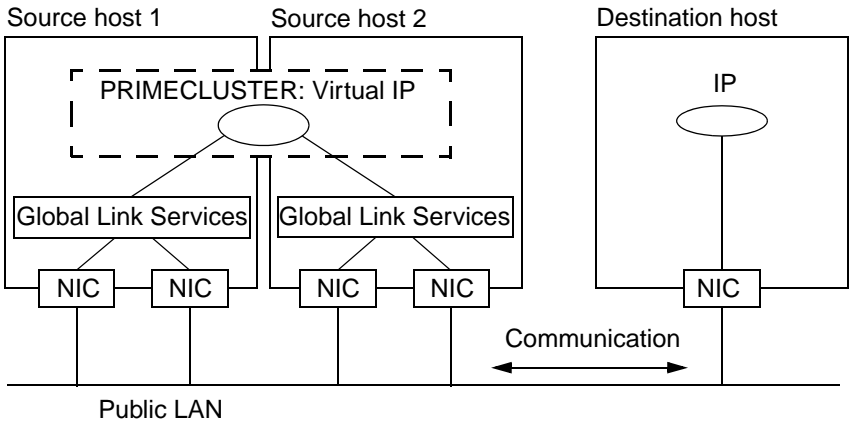

Figure 15: NIC switching mode

4 Cluster interconnect details

This chapter discusses the differences between a cluster interconnect and a network as well as the requirements of the PRIMECLUSTER cluster interconnects. It ends with a discussion of design considerations for the cluster interconnects.

This chapter discusses the following:

- The section “Overview” on page 55 provides an overview of the cluster interconnect.
- The section “Cluster interconnect requirements” on page 57 details the requirements of PRIMECLUSTER cluster interconnects.

4.1 Overview

The cluster interconnect is the most fundamental part of the cluster. All of the cluster's services rely on the cluster interconnects to transport messages between nodes and to determine the state of a node by its ability to respond to heartbeat requests.

4.1.1 A cluster interconnect is different from a network

The function of a cluster interconnect is different than the traditional use of a network in several ways; therefore, it is useful to think of them as separate technologies. The highest priority use of the cluster interconnects is to carry heartbeat requests and responses.

Heartbeat messages are used to determine the state of the nodes and the cluster interconnects. When a message fails to get through, the cluster software assumes that a failure has occurred and takes action to recover. However, no network is 100 percent reliable, and the PRIMECLUSTER ICF protocol tolerates errors such as lost packets or out of order delivery.

In the cluster interconnects, the physical connections are redundant so that if one fails, one or more remain to carry the messages. However, a sustained outage of all cluster interconnects results in the cluster management software taking action to recover as if a node had failed.

4.1.2 Network availability

Most users assume that their networks are always available. However, most networks have periods of downtime quite regularly. Network administrators need to reprogram switches and routers and perform other maintenance operations; they do this at times of low network usage and the outages last for only a few seconds. A cluster uses its interconnect continuously, 24 hours a day, 7 days a week. As a result, a routine network maintenance operation that would not even be noticed by a typical network user or application can result in a cluster recovery action that shuts down systems and moves applications.

Temporary outages can result from other causes as well. One of the most convenient improvements to Ethernet has been the speed-agile ports on hubs, switches, and routers. These allow the user to plug an Ethernet device into a port and not have to worry about speed matches between the network interface card (NIC) and the port. However, there is a cost to this technology. If a hub or switch gets too busy, it can lose its state and will have to renegotiate with the NIC. This renegotiation takes several seconds, during which time no messages are passed. As a result, a cluster interconnect on this type of device could disconnect long enough so that the cluster takes a recovery action such as shutting down a node.



To avoid renegotiation outages, it is recommended that users configure the network interface card, router, and hub at a fixed speed. If all of the redundant interconnects are unavailable for five seconds, then the software assumes that a node failure has occurred.

Another temporary outage can occur when an Ethernet device is first opened. This starts the chain of events that triggers the switch port to which the Ethernet device is attached to begin its configuration process. Some switches take over one minute for this configuration to complete. PRIMECLUSTER may interpret the lack of responses on this port incorrectly and assume no other cluster nodes are configured on this port.

Because different network configurations and devices have different requirements, PRIMECLUSTER allows the system administrator to tune the parameters associated with the cluster interconnect. Refer to the *Cluster Foundation Configuration and Administration Guide* for more details.

4.1.3 Interconnect protocol

PRIMECLUSTER supports either the Ethernet protocol or IP as the transport layer for the cluster interconnects. This does not mean that TCP/IP is the underlying protocol used by the cluster services.

TCP/IP is designed to reliably deliver messages through a variety of obstacles such as different network types, multiple routers or switches, and failures in the network. TCP/IP works well and has been almost universally adopted as the protocol stack of choice for a wide variety of services. But TCP/IP is not the right choice for cluster interconnects.

The ICF (Internode Communication Facility) protocol used by PRIMECLUSTER is designed specifically for cluster communications. It is a low-latency protocol that guarantees ordered delivery of messages. ICF has a lower overhead than TCP/IP, which is important for parallel applications. ICF uses the Ethernet protocol or is a service over IP (CF/IP).



Devices that only accept TCP/IP cannot route the ICF protocol when it is configured directly on the Ethernet. In this instance, if you need to use a router, it must be a level-two router.

ICF is only usable by the CF internal components and is not available to user-level resources. To provide applications with an access to the cluster interconnects, the Cluster Interconnect Protocol (CIP) is used. CIP provides a standard TCP/IP protocol suite over ICF.

4.2 Cluster interconnect requirements

PRIMECLUSTER uses all significant forms of Ethernet and most devices that support TCP/IP, including mixtures of different technologies. The interconnects must be redundant to assure reliable operation of the cluster; that is, there must be two or more independent connections (interconnects) between all of the nodes in the cluster. Each interconnect must support all of the nodes in the cluster. Refer to the installation guides for products for a list of all the Ethernet devices that were known to work at the time of release.

4.2.1 Redundancy

To be redundant, the cluster interconnect must use two or more independent connections and data paths. An independent connection means that the Ethernets do not share any common components. An independent data path means that the individual interconnects do not share any part of their route between nodes. An example of a redundant cluster interconnect is as follows:

- Only one port is used for each Ethernet board. If more than one port of the same board is used as a cluster interconnect, these ports would be a common point of failure.
- Connections to nodes must be independent.
- No two interconnects can share the same hub, switch, or routers.

Figure 16 shows a typical four-node cluster. In this diagram, there are two hubs. Each of these hubs has their own power connection on different circuits. If the hubs were connected to the same power strip in a rack, for example, the power strip would be a single point of failure for the cluster interconnects.

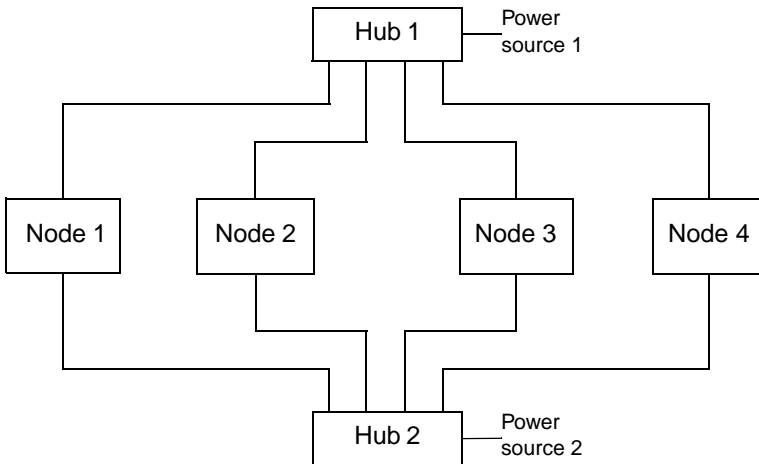

Figure 16: Typical four-node cluster

4.2.2 Routes

Since redundant interconnects are required for reliability, ICF is designed to use all of the available bandwidth. Each connection between two nodes in the cluster is called a route. When ICF has a message to send to another node, it chooses a route so that the message traffic is balanced between all the available routes. In the four-node cluster in Figure 16, each node has two routes to each of the other nodes.

4.2.2.1 Heartbeats

[State transition mechanism]

When everything is functioning properly in the cluster, all of the routes are in the UP state (available for use). Every UP route participates in carrying message traffic if it functions at the same speed (mixed speed interconnects are discussed below.) In addition, every route is always used for heartbeat requests. (A heartbeat is a message indicating that a node is functional.) If a certain number of heartbeat requests fail on a route, then that route is marked as DOWN. A DOWN route is never used for message traffic. However, heartbeat requests are still attempted on the DOWN routes, and if one succeeds, the route is returned to the UP state. This last behavior is sometimes called self-healing routes. The use of all the UP routes for message traffic is called port aggregation or trunking.

[Monitoring method]

In the two-node cluster system, the two nodes are monitoring each other by heartbeats. In a cluster system with three nodes or more, these nodes are monitoring the system by sending heartbeats in a ring, for example, from node 1 to node 2, from node 2 to node 3, and from node 3 to node 1. If no heartbeat response is received from all the routes of interconnects in the monitoring node within the half of the heartbeat latency (10 seconds by default), all nodes in the cluster start request heartbeats to check the status of nodes that are suspected to have a failure. The request heartbeat stops when responses are returned from the monitoring nodes.

Failures of heartbeat requests can come from several causes. When a network component fails, that route is not usable and the behavior is the same as described in the previous paragraph. When a node is DOWN to the only remaining route to another node, PRIMECLUSTER does not mark this route as DOWN, rather it marks the node as LEFTCLUSTER.

LEFTCLUSTER is a node state that indicates that the node cannot communicate with other nodes in the cluster. That is, the node has left the cluster. Once a node is marked as LEFTCLUSTER or DOWN, no more heartbeat attempts are made on any of the routes to the node until the node rejoins the cluster.



The last route to a node is never marked DOWN, even if the node is in the LEFTCLUSTER or DOWN state.

Sometimes, events happen on a node that prevent the node from responding to heartbeat requests for some reason other than a failure. For example, a Fibre Channel controller can prevent other network device drivers from executing while attempting a link recovery. This can result in a false detection of node failure. To allow for some flexibility in responding to this condition, the number of missed heartbeat requests on the final route to a node before declaring the node as LEFTCLUSTER is tunable.

You can only adjust the number of failed-heartbeat requests that occur before declaring the node LEFTCLUSTER. The other parameters for ICF are not tunable. It is important that the route-detection algorithm marks routes as down as soon as possible, so that messages are switched to alternate routes without a noticeable delay. If a route is momentarily not available, for whatever reason, the self-healing mechanism will quickly reactivate the route after it becomes functional. The *Cluster Foundation Configuration and Administration Guide* has details on tuning the ICF parameters.

PRIMECLUSTER also supports the use of non-symmetric interconnects, for example, one interconnect could use gigabit Ethernet and a second fast-Ethernet. When making decisions about routing, the interconnect speed is also considered. In the previous example, the gigabit Ethernet would always be used in preference to the fast-Ethernet whenever it is available. If there are multiple interconnects at the same speed, the port aggregation is done across all the devices with the same speed. Heartbeat requests are always sent on every interconnect, independent of the interconnect speed.

4.2.3 Properties

When designing cluster interconnects, it is important for users to consider the following:

- Bandwidth
- Latency
- Reliability

- Device interface
- Security

4.2.3.1 Bandwidth

PRIMECLUSTER does not require much bandwidth for its own use. This is significant because the end-user's application requirements for bandwidth are much more important. PRIMECLUSTER requires less than 2 Kbits/s on each of the cluster interconnects. Since the cluster interconnects share bandwidth, the total bandwidth available to the user's application is nearly the sum of all of the bandwidth for each interconnect.

Refer to table 1 as an example of bandwidth use. Suppose that in the configuration in Figure 16 that there are two 100 Mbits/s Ethernets configured for the cluster interconnect. Assume that the available bandwidth for each cluster interconnect is 10 Mbytes/s, and assume that the end-user application needs 4.5 Mbytes/s on each node for the cluster file system and other activities. (This is an example—the actual bandwidth used by an application varies, depending on the application.)

Item	Bandwidth	Total bandwidth
Two interconnects: 100 Mbits/s Ethernet	10 MBytes/s	20 MBytes/s
PRIMECLUSTER requirements per inter- connect and per node	2 Kbits/s (4 x 2 x 2 = 16 Kbits/s)	16 Kbits/s
User application per node	4.5 MBytes/s (4.5 x 4 = 18 MBytes/s)	18 MBytes/s
Total		18.02 MBytes/s 90% total use

Table 1: Example of interconnects with two 100 Mbits/s Ethernet boards

For this example, two fast-Ethernet interconnects use over 90 percent of the bandwidth.

i It is recommended that an initial installation has at least 30 percent available bandwidth capacity because the latency of the interconnect is adversely affected when total use nears 100 percent.

For this example, workload and configuration, one additional fast-Ethernet interconnect should be added to provide the excess capacity. table 2 shows the same calculation with this addition.

Item	Bandwidth	Total bandwidth
Three interconnects: 100 Mbits/s Ethernet	10 MBytes/s	30 MBytes/s
PRIMECLUSTER requirements per inter- connect and per node	2 Kbits/s (4 x 3 x 2 = 24 Kbits/s)	24 Kbits/s
User application per node	4.5 MBytes/s (4.5 x 4 = 18 MBytes/s)	18 MBytes/s
Total		18.02 MBytes/s 60% total use

Table 2: Example of interconnects with three 100 Mbits/s Ethernet boards

This new configuration gives a comfortable 40 percent available bandwidth margin. PRIMECLUSTER supports a maximum of eight interconnect devices.

4.2.3.2 Latency

There are no absolute latency requirements in PRIMECLUSTER. As previously stated, PRIMECLUSTER relies on heartbeat requests and responses to determine that nodes or other resources are functional. When a heartbeat is not received in a preset interval, PRIMECLUSTER starts recovery actions. The intervals depend upon what PRIMECLUSTER is monitoring. The Cluster Foundation (CF) software on each node sends a heartbeat request every 200 ms on each interconnect to every other node in the cluster. By default, CF tries 50 times to get a response before a node is marked as LEFTCLUSTER.

The 200 ms interval is a reasonable choice for a maximum latency in the cluster interconnects. This interval is long enough so that a small message and response can span transcontinental distances. This interval also allows for recovery from lost packets or other errors that can cause a few requests or responses to be lost in the interconnect.

For interconnect latency, an end-user application can have a different set of requirements. For example, applications like OPS will find that 200 ms is far too long an interval for latency. This shows how users must consider the needs of the applications during the design of their cluster solution.

All commercially available Ethernet hubs and switches meet the latency requirements of PRIMECLUSTER and those of most applications. When latency is measured with hubs and fast Ethernet, typical results are between 15 and 60 microseconds for user-level applications.

i Some routers, especially in heavily used networks, can introduce excessively high latencies. For this reason, it is recommended that you do not use routers with the cluster interconnect. If routers cannot be avoided, it is essential that you address the latency concerns.

4.2.3.3 Reliability

Ethernet as an interconnect technology has not shown any problems with PRIMECLUSTER. The communications protocol used by PRIMECLUSTER is ICF. ICF guarantees that messages are delivered correctly and in order to its clients. However, ICF was designed with fairly reliable communications in mind. When the cluster interconnect is reliable, ICF has very low overhead, but when it is unreliable, the overhead of ICF increases. This is similar to other protocols like TCP/IP; errors in the interconnect will result in messages being resent.

i Resending messages consumes bandwidth and increases latency and should be avoided at all times.

i An Ethernet error rate greater than 1 error per 1,000,000 bytes indicates that there is some problem with the Ethernet layer that should be investigated. (Use the command `netstat(1)` to find the error rate.)

4.2.3.4 Device interface

i This section is for Solaris only.

PRIMECLUSTER depends on the DLPI (Data Link Provider Interface) for devices in Solaris. If a device does not support a DLPI interface, PRIMECLUSTER does not recognize the device as eligible for use as a cluster interconnect. In addition, the device must appear to be an Ethernet device. Some devices support TCP/IP, but are not Ethernet-type devices. Keep in mind that PRIMECLUSTER does not use TCP/IP for its cluster interconnects; rather it uses the Ethernet protocols. It is advisable to choose an interconnect device from the list of supported devices (refer to the installation guides for products as detailed in the section “Related documentation” on page 2).

4.2.3.5 Security

With the PRIMECLUSTER family of products, it is assumed that the cluster interconnects are private networks; however, it is possible to use public networks as cluster interconnects because ICF does not interfere with other protocols running on the physical media. The security model for running PRIMECLUSTER depends on physical separation of the cluster interconnect networks.



For reasons of security, it is strongly recommended not to use public networks for the cluster interconnects.

The use of public networks for the cluster interconnects allows any machine on that public network to join the cluster (assuming that it is installed with the PRIMECLUSTER products). Once joined, an unauthorized user, through the node, would have full access to all cluster services.

5 Reliant Monitor Services (RMS)

This chapter introduces the basic concepts of RMS. It begins with an overview of the basic terms and concepts used to provide high availability by means of RMS, and then it goes into more detail on how RMS works.

This chapter discusses the following:

- The section “RMS overview” on page 67 describes the concepts of high availability, redundancy, and switchover.
- The section “RMS monitoring and switchover” on page 71 describes the components of RMS and explains how they work together to achieve high availability.
- The section “RMS administration” on page 77 introduces administering RMS by means of the GUI (graphical user interface) and the CLI (command-line interface).
- The section “Customization options” on page 77 discusses customizing RMS for a particular site.

5.1 RMS overview

RMS is a software monitor designed to provide system-level High Availability (HA) to applications. A minimum of two nodes with shared access to common storage are administered from a cluster console. As the PRIMECLUSTER HA monitor, RMS uses detectors to monitor the state of components and resources for applications. If a resource or application fails, the event is notified by the detector and reported to RMS. RMS then takes the appropriate action as described in the sections that follow.

Figure 17 shows the components of a basic RMS cluster on Solaris.

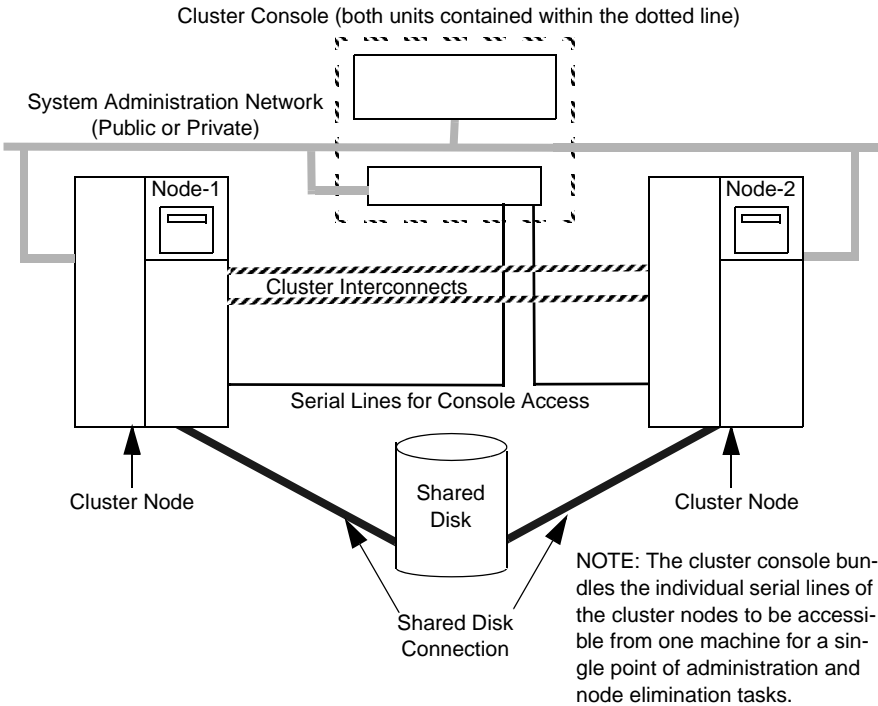

Figure 17: RMS cluster on Solaris

For RMS, high availability means *maximum availability of applications* rather than *uninterrupted availability of individual nodes*.

RMS accomplishes high availability in two ways: redundancy and switchover.

5.1.1 Redundancy

To provide high availability of RMS resources, RMS takes advantage of the following redundancy scheme:

- Multiple nodes, each configured to assume the resource load of any other RMS node
- Duplication of stored data using mirror disks, hardware RAID, and remote mirroring

- Multiple-path access to storage media
- Multiple communications channels dedicated to internode communications

Multiple nodes

An RMS configuration is made up of multiple nodes, each containing identical operating systems and RMS software. The maximum number of nodes in an RMS configuration is theoretically unlimited. Refer to the installation guides for products as detailed in the section “Related documentation” on page 2 for the qualified number of nodes.

Shared storage

All nodes in the RMS configuration must have access to whatever data is shared. Typically, all nodes have the ability to access shared disks over a SAN. However, other access methods, such as Network Attached Storage are possible.

RMS network

RMS uses standard TCP/IP protocols for communication between the nodes in the configuration. Because this communication is to monitor the status of other nodes and because any communication failures would be likely to endanger consistency, RMS uses the Internode Communication Facility (ICF) interface provided by PRIMECLUSTER (refer to section “Interconnect protocol” on page 57 for more information). The RMS network is layered over the PRIME-CLUSTER interconnects, and they both share the same physical media.

5.1.2 Application switchover

RMS operates on an object-oriented basis. The objects can be almost any system component, such as virtual disks, file system mount points, processes, and so on. These objects are defined as *resources*. A resource is categorized into a grouping called a *object type*. An object type has specific properties, or attributes, which limit and define what monitoring or action can occur in relation to that resource. Resources are monitored by programs called *detectors*. This very general object-oriented design permits a high degree of flexibility in the type and level of monitoring.

Resources which are dependent on each other can be grouped together to form logical applications. Failure of any resource in such a group generally triggers a reaction by the entire application.

5.1.2.1 Automatic switchover

Any failure of a resource triggers a user-defined reaction. In most cases, the most significant reaction to failures is switchover.

A *switchover*, sometimes known as failover, consists of first bringing an application into a well-defined `Offline` state and then restarting the application under the control of RMS on another node. RMS supports symmetrical switchover, which means that every RMS node is able to take on resources from any other RMS node. For example, if the node that is running an application fails, RMS automatically shuts down the node where the failure occurred and redistributes its application load to another operational RMS node.

The details of performing automatic switchover are defined in user-specified scripts and configuration files that RMS accesses when a failure is recognized. The RMS wizards are generally used to create these files.

5.1.2.2 Manual switchover

Resources can be switched manually for such purposes as hardware maintenance. For example, in a two-node RMS configuration, all applications can be temporarily moved to one node while maintenance is performed on the other. Then all applications can be switched back to the operational node while maintenance is performed on the second node. The only impact to users might be a momentary interruption in service while the applications are being switched, and perhaps a slowdown in response time while all applications are operating on a single node.

5.1.2.3 IP aliasing

RMS uses IP aliasing to allow switchover of the communication link. It is possible for several IP addresses (aliases) to be allocated to one physical network interface. With IP aliasing, the user is able to continue communicating with the same IP address, even though the application is now running on another node.

5.1.2.4 Data integrity

RMS ensures that all resources of an application are offline on the current node before initiating a switchover. These resources are then switched online on another operational node. This behavior ensures that multiple nodes do not access the same resource, thus protecting against data loss.

In the rare event of simultaneous multiple faults, RMS protects against data corruption by preventing a switchover. This design means that in certain circumstances, switchover may be prevented entirely.

Although high availability is the goal of RMS, data integrity takes priority over high availability.

5.2 RMS monitoring and switchover

The RMS software is composed of the following processes, scripts, files, and parameters that work together to maintain high availability of the RMS resources:

- Base monitor
- Configuration files
- Configuration scripts
- Detectors
- RMS environment variables

Configuration files, scripts, and environment variables can be customized, allowing switchover scenarios to be tailored for site-specific needs (for information on customization, refer to the section “Customization options” on page 77).

5.2.1 Base monitor

The base monitor is the central process that monitors a node from the RMS cluster. The base monitor performs the following functions:

- Controls and coordinates all state changes in RMS
- Ensures that the appropriate action is taken if there are any problems with the monitored resources
- Obtains information concerning resources and the action to be taken from an RMS configuration file, which the system administrator creates, according to the requirements for use by RMS

The base monitor is started by the Cluster Admin GUI, or with the `hvc_m` command, and runs as a process under the name `bm` (base monitor) on every node in the cluster.

5.2.2 Configuration file

An RMS *configuration file* is a text file that is usually generated by RMS configuration tools (RMS Wizard Tools or PCS Wizards). It provides input to the base monitor that consists of definitions of the resources that are to be monitored by RMS, including their interdependencies.

5.2.2.1 Interdependencies

In RMS, the terms *parent* and *child* are used to represent dependent relationships between objects and their resource objects. The term *leaf object* is used to indicate that an object in a system graph has no children. In the configuration file, the leaf object definition is at the beginning of the file. A leaf object cannot have children, while a child can be both a parent and a child.

Figure 18 helps illustrate the parent/child relationships between objects.

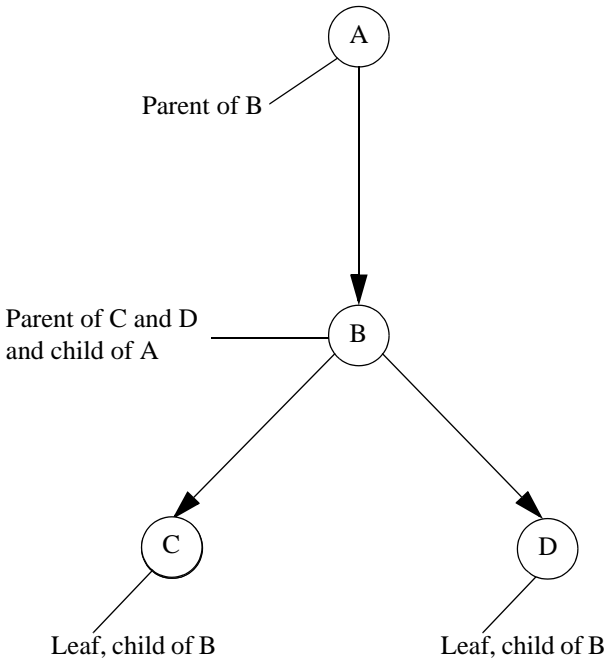

Figure 18: Configuration file interdependencies

Figure 18 shows the following relationships:

- Object A requires the resource B to function properly, making A a parent of B and B a child of A.
- Object B requires the resources C and D to function properly, making B a parent of C and a parent of D.
- Objects C and D are leaf objects because they do not have any children. They are also children of B.

5.2.2.2 Object types

A *object type* is a collection of similar resources monitored as a group (for example, all object types in a group using the same disk drives). Each object type has certain properties, or *attributes*, which limit or define what monitoring can occur for that type of resource. The attributes associated with a particular object type define how the base monitor acts and reacts for a resource of that object type during normal operations. Attributes commonly specify a device name or a script, and can be specified in any order in the object definition for that resource.

Some attributes are mandatory; others are optional. An example of a mandatory attribute is a device name for a `vdisk` object type. Typical optional attributes are scripts which are executed under certain conditions. Most attributes can be used for most object definitions.

Some attributes are valid only for particular object types, while some object types require that specific attributes be included in their object definitions.

5.2.2.3 Object definitions

A *object definition* is a statement in the configuration file, beginning with the keyword `object`, that describes a particular resource in terms that RMS understands. Specifics of an object definition include the following:

- Object type
- Resource name
- Attributes
- Child resources that the particular resource depends upon

After RMS has been installed and verified, the configuration file must be created before RMS can begin monitoring resources. If a resource does not have an object definition in the configuration file, the resource is *not* recognized by RMS.

5.2.3 Scripts

An RMS configuration *script* is a shell program or executable that reacts to and/or invokes a change in the state of an RMS resource.

The following states are possible for all RMS resources:

- Faulted
- Offline
- OfflineFault
- Online
- Unknown
- Wait
- Deact
- Inconsistent
- Standby
- Warning

All RMS actions and reactions are executed as scripts. Without scripts, RMS is only capable of monitoring resources, not activating any changes. Scripts are identified as attributes in the object definition for the particular resource, and are run by the base monitor as needed in response to detector-reported state changes. For example, if the state of an RMS network resource changes from `Online` to `Faulted`, the base monitor responds by initiating the fault script listed in the object definition for that resource.

RMS distinguishes between scripts which are designed to change a state (request-triggered scripts) and scripts which represent a reaction to a specific state (state-triggered scripts).

Request-triggered scripts include:

- PreOnlineScript
- PreOfflineScript
- PreCheckScript
- OnlineScript
- OfflineScript
- OfflineDoneScript

State-triggered scripts include:

- PostOnlineScript
- PostOfflineScript
- FaultScript

Your RMS may include additional scripts.

For further information on resource states and scripts, refer to the *RMS Configuration and Administration Guide*.

5.2.4 Detectors

A *detector* is a process that monitors the state of a certain type of resource, such as mirrored disks. A detector is started by the base monitor when RMS is started.

Each detector uses an internal table to track information about one or more resources. The detector scans each resource listed in its internal table, obtains the current state of each resource, and then compares the current state to the previous state. If the current state is not the same as the previous state, the detector reports the current state to the base monitor through the detector report queue for that type of resource. Based on the information from the configuration file, the base monitor then determines, what, if any, action is necessary for the particular situation involving that resource.

Figure 19 illustrates the interactions between the base monitor and the RMS detectors.

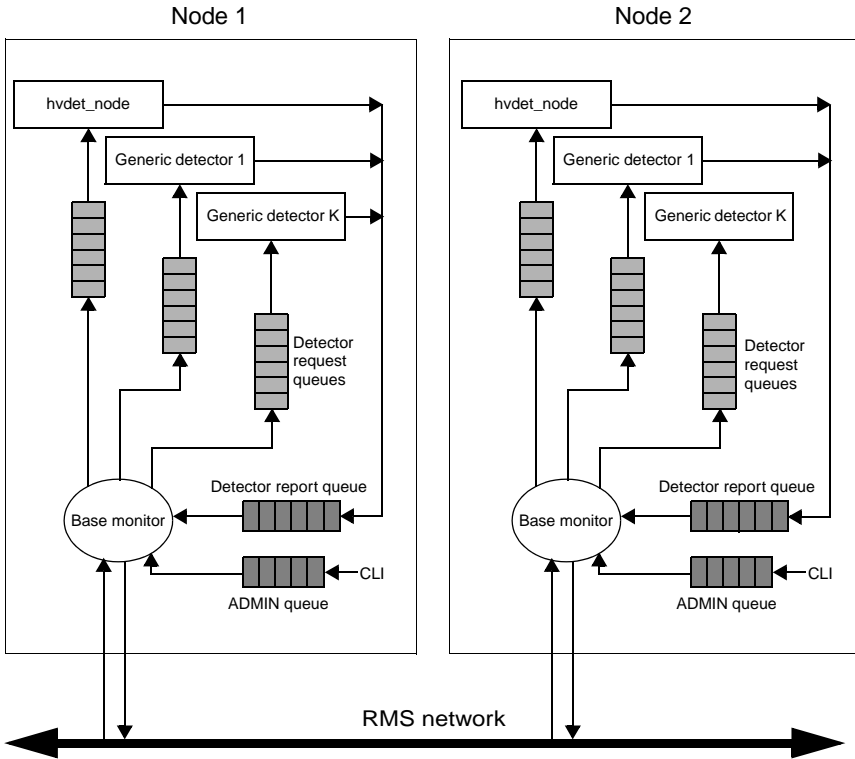

Figure 19: Base monitor interactions

5.2.5 RMS environment variables

Environment variables specify values for the base monitor during startup system events. RMS comes with a number of high availability environment variables, such as `HV_AUTOSTART_WAIT`, `RELIANT_PATH`, and so on. The default settings of these RMS environment variables can be adjusted as needed for individual clusters and applications.

5.3 RMS administration

You can administer RMS from the command-line interface (CLI) or from the graphical user interface (GUI). The preferred method for RMS administration is the GUI, which is called Cluster Admin.

5.4 Customization options

Fault detection and recovery schemes can be customized to fit the needs of each site by modifying configuration files, detectors, and scripts for the resources that are to be monitored by RMS. These modifications should be planned in advance and implemented after RMS installation is completed, and before RMS is declared operational.

5.4.1 Generic types and detectors

RMS provides a generic resource type for defining special resources that cannot use the system-level supplied resource types. The generic detector interface allows the definition of up to 64 custom resource types and their detectors.

6 RMS configuration tools

This chapter introduces the basic concepts of the RMS configuration tools. A brief overview includes identification of the two configuration tool types (RMS Wizards and PCS), and some of the functions they provide.

This chapter discusses the following:

- The section “RMS configuration overview” on page 79 specifies the two configuration tool types, and outlines RMS configuration tool architecture.
- The section “Configuration tool foundations” on page 81 describes the architecture and functions of the RMS Wizard Tools and PCS Wizards.
- The section “RMS Wizard Kit and PCS Application Wizards” on page 82 describes the architecture and functions of the RMS Wizard Kit and the PCS Application Wizards.

6.1 RMS configuration overview

Creating an RMS configuration file (see the section “Configuration file” on page 72) is a complex task that requires detailed knowledge of both the user applications and the RMS environment.

There are two configuration tool types that can facilitate the creation of RMS configurations and simplify the subsequent operation of RMS. Each configuration tool type consists of a configuration tool foundation, and a set of application wizards (see Figure 20):

- RMS Wizard Tools and the RMS Wizard Kit
- PRIMECLUSTER Configuration Services (PCS) Wizards and the PCS Application Wizards—alternative RMS configuration tools with a GUI architecture



The two configuration tool types (RMS Wizards and PCS) are mutually exclusive with respect to installation and operation.

The RMS Wizard Kit and PCS Application Wizards are layered onto the configuration tool foundations, which interact directly with the RMS Base, as is shown in Figure 20.

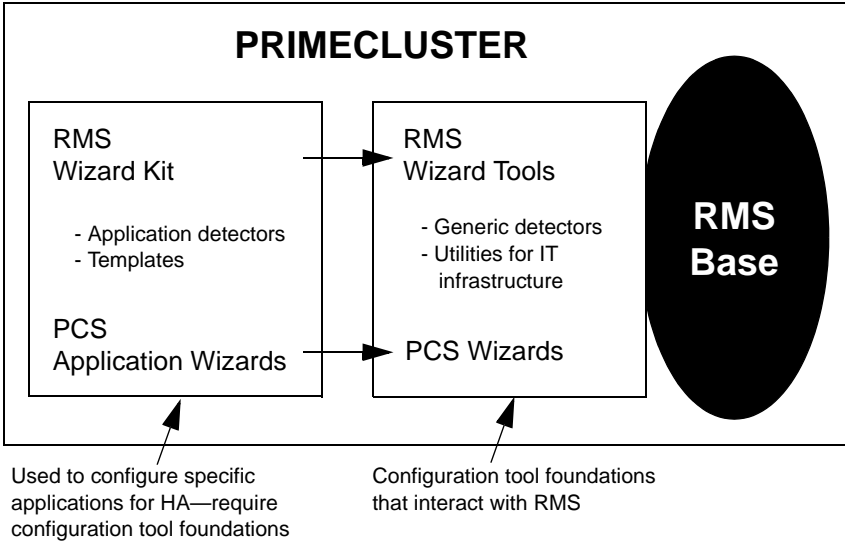

Figure 20: Wizard architecture



For additional information about the RMS Wizard Tools and the RMS Wizard Kit, see the *Reliant Monitor Services (RMS) with Wizard Tools (Solaris, Linux) Configuration and Administration Guide*.

For additional information about the PCS Wizards and the PCS Application Wizards, see the *Reliant Monitor Services (RMS) with PCS (Solaris, Linux) Configuration and Administration Guide*.

6.2 Configuration tool foundations

The configuration tool foundations (RMS Wizard Tools and PCS Wizards) interface with the RMS base. They simplify the configuration setup and work with RMS in the HA (high availability) cluster environment. Features of the configuration tool foundations include:

- Create and distribute complete RMS configuration files
- Prevent or allow configuration changes
- Guide the user through the process of selecting the components of the configuration, and prompts for specific information required by these components
- Present standard resources in a logical sequence to generate correct configuration structures
- Include quality-assured components to monitor and control (detectors and scripts) cluster operations
- Work in conjunction with RMS Wizard Kit or PCS Application Wizards to create RMS configurations

To support additional HA configurations, there are some utility wizards offered as part of the configuration tool foundation that manage some system standard resources and applications not covered by a specific application wizard, such as the following:

- Mounting/unmounting file systems
- Installing/uninstalling IP aliases
- Configuring/deconfiguring virtual disks

Shared-storage applications

Shared-storage application wizards configure RMS for different types of disk storage. For example, you can configure software-based solutions such as GDS or Veritas VxVM, or you can configure hardware solutions like EMC. These wizards can also configure multiple SAN (Storage Area Network) modules, allowing you the capacity to stack modules.

6.3 RMS Wizard Kit and PCS Application Wizards

The RMS Wizard Kit and PCS Application Wizards configure RMS for a unique enterprise application. The RMS Wizard Kit or PCS Application Wizard produces a complete RMS configuration for the user, which is then used by the corresponding RMS configuration tool foundation and RMS. These wizards are distributed separately from the configuration tool foundation software.



For information on the availability of specific RMS Wizard Kit and PCS Application Wizards, contact your local customer support service or refer to the *RMS Wizards documentation package*, available on the PRIME-CLUSTER CD).

RMS Wizard Kit and PCS RMS Wizard Kit and PCS Application Wizards allow the administrator to adapt to the user's needs for HA for a specific application. They contain predefined application-specific detectors, rules, and templates for entering user parameters for the application.

Application-specific detectors monitor RMS resources for a particular application. Failure of an RMS resource triggers a user-defined response. See the section "Detectors" on page 75 for more information on how detectors work within RMS.

7 SIS

This chapter introduces the basic concepts and components of the Scalable Internet Services (SIS). After a brief overview, it explains how the SIS components function and the services that they provide.

This chapter discusses the following:

- The section “SIS overview” on page 83 introduces the concepts of the SIS technology.
- The section “SIS design” on page 87 shows an example of how a SIS cluster might function.
- The section “VIP load-balancing algorithms” on page 88 details the algorithms available for users of SIS.
- The section “Proxy addresses” on page 88 describes the uses and capabilities of proxy addresses.
- The section “Private addresses” on page 89 describes the uses and capabilities of private addresses.
- The section “Failover” on page 89 discusses the concepts and capabilities of backup nodes.

7.1 SIS overview

SIS provides scalable and fault tolerant network services based on the underlying PRIMECLUSTER technology. SIS enables the PRIMECLUSTER to act as a scalable, reliable, and easily managed network server system. The services in a SIS cluster are accessed via one or more Virtual Interface Provider (VIP) addresses, and the cluster appears to clients as a single network server.

Nodes in a SIS cluster share the load for different services. With SIS, users can configure load sharing per service, and they can fine-tune unique application and site needs with a variety of load-balancing algorithms.

SIS eliminates single points of failure and ensures availability as follows:

- If any of the SIS nodes fail, SIS schedules requests around the failed nodes.
- If any of the SIS modules fail, they gracefully recover.
- After a failed node restarts and you have started SIS on it, the node will seamlessly join the cluster to restore maximum performance.
- SIS will recover from NIC failures by routing outgoing packets from a working NIC on a functional node.

7.1.1 Features

SIS has the following features:

- Single IP target address for all external users
- Ease of adding nodes and services
- TCP and UDP services can be scheduled on a per-port basis
- Many load-balancing algorithms available
- Seamless handling of node failures, service failures, and component failures
- Flexible backup-node management
- Satellite nodes
- Support for Windows 2000 service nodes
- Proxy addresses for cluster use
- Private communication between nodes
- Software-based solution
- GUI-based configuration and administration interface

The sections that follow discuss the various types of SIS modules.

7.1.2 Service nodes

Service nodes offer network services such as web services and directory services. If a service node fails, services are scheduled around it. When a failed service node comes back up, it rejoins the SIS cluster seamlessly.

7.1.3 Gateway nodes

There is one gateway node per VIP address. All incoming packets are received by this node and forwarded to the selected service node, depending on the scheduling algorithm for the service. If a gateway node fails, another node seamlessly assumes the role of the failed gateway node.

7.1.4 Primary database node

The primary database node keeps the static and dynamic data of the SIS cluster. The static information may include the list of nodes in the SIS cluster, the VIP address and services offered, and the scheduling algorithms. The dynamic information includes the current list of connections and the current status of the SIS cluster.

7.1.5 Backup database nodes

A backup database node assumes the role of the primary database node when the primary database node fails for any reason. There can be more than one backup database node. Each backup database node contains the static configuration details, and SIS collects the dynamic configuration items from all the available nodes; therefore, network disruption is kept to a minimum.

7.1.6 Satellite nodes

Satellite nodes run a version of SIS that provides better performance while supporting the same network services as the complete SIS package. The major differences between satellite nodes and non-satellite nodes are:

- Satellite nodes do not need to be members of the CF cluster. The satellite version of SIS is available for Windows 2000 Server as well as Solaris and Linux.
- Satellite nodes cannot act as database or gateway nodes.

Figure 21 illustrates a five-node SIS configuration with three SIS core nodes, one Linux satellite node, and one Windows 2000 satellite node.

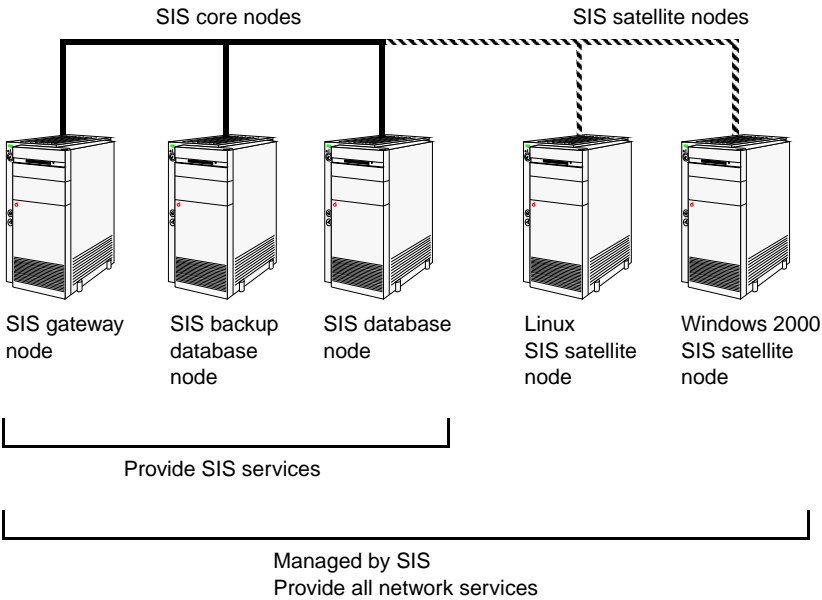

Figure 21: SIS cluster with satellites nodes example

7.2 SIS design

In Figure 22, the SIS cluster consists of one gateway node and two service nodes. The steps that follow give an example of how a SIS cluster performs after receiving a request from a client.

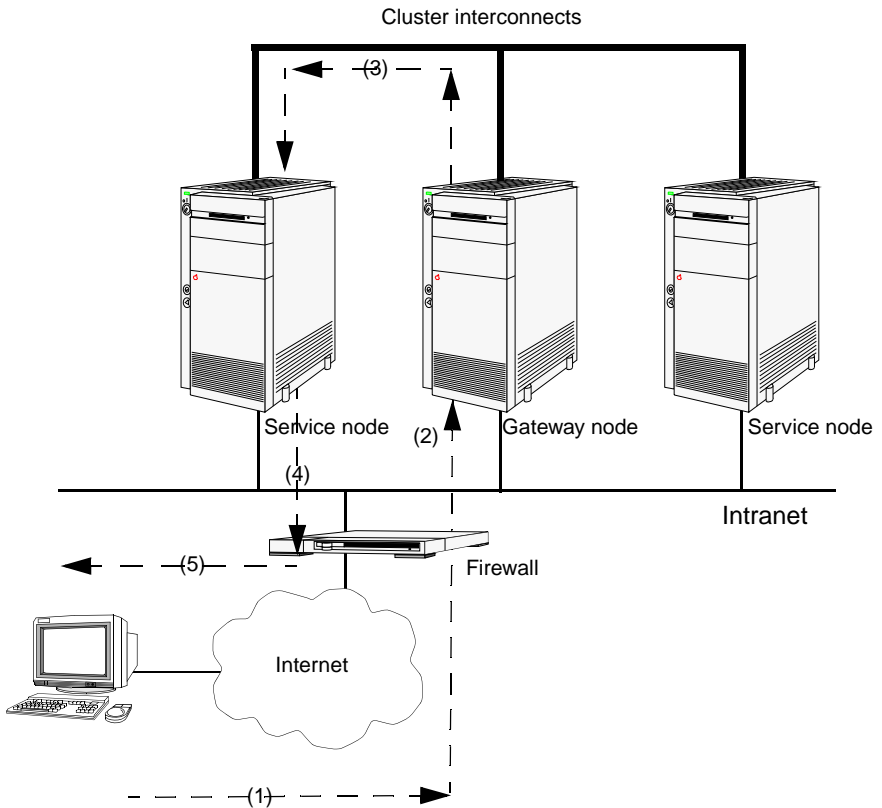

Figure 22: SIS client/server illustration

Referring to Figure 22, the SIS cluster functions as follows:

1. Client requests services through the network, seeing only one IP address.
2. The gateway node receives the initial connection request.

3. The gateway node and the database node choose a service node, which can be a satellite node, based on the scheduling policy and the availability services. Only the initial request requires this scheduling. Subsequent data packets are routed directly to the service node.
4. The service node processes the request and responds directly to the client.
5. The client receives the response from the network.

7.3 VIP load-balancing algorithms

SIS provides the following load-balancing algorithms, which can be configured on a per-port basis:

- Keep local—The gateway node answers the request without any processing overhead.
- Client based—The service node is chosen based on the client's IP address.
- System load—The system with the minimum system load is chosen. The system load is calculated by SIS using an internal algorithm.
- Round robin—All available nodes are chosen in a circular way.
- Spill over—If the system load on all primary nodes is equal or greater than the configured threshold, a backup node is chosen to lessen the load.
- Weighted connection count—SIS chooses the system with the least number of connections. Each node may be assigned a weight, and the connection count is normalized according to this weight.

7.4 Proxy addresses

Proxy addresses can be defined to assign one or more virtual addresses to a node. Since proxy addresses have failover capabilities, they also provide high availability. The possible uses are as follows:

- Co-hosting multiple addresses to one node
- Assigning external connectivity to nodes that do not have connections to the Internet
- Allocating backup nodes to a node

7.5 Private addresses

Private addresses can be configured on each of the available nodes in a SIS cluster. These addresses are commonly used for inter-node communication by means of the interconnects and the IP protocol. Private addresses are secure, fast, and use redundant interconnects to assure high availability.

7.6 Failover

One or more nodes can be service nodes for each service. Each of these service nodes can have one or more backup nodes. The backup nodes can be either hot standby or nodes which are doing something else. If a node or nodes fail, then the configured backup nodes replace the failed node or nodes as determined by the configuration file.

Glossary

Items in this glossary that apply to specific PRIMECLUSTER products are indicated with the following notation:

- (CF)—Cluster Foundation
- (PCS)—PRIMECLUSTER Configuration Services
- (RMS)—Reliant Monitor Services
- (RCVM)—Volume Manager (not available in all markets)
- (SIS)—Scalable Internet Services

Some of these products may not be installed on your cluster. See your PRIMECLUSTER sales representative for more information.

AC

See *Access Client*.

Access Client

GFS kernel module on each node that communicates with the Meta Data Server and provides simultaneous access to a shared file system.

activating a configuration (RMS)

Preparing an RMS configuration to be run on a cluster. This involves two major actions: first, the configuration is *generated* on the host where the configuration was created or edited; second, the configuration is *distributed* to all nodes affected by the configuration. The user can activate a configuration using PCS, the RMS Wizards, or the CLI.

See also *generating a configuration (RMS)*, *distributing a configuration (RMS)*.

Administrative LAN

In PRIMECLUSTER configurations, an Administrative LAN is a private local area network (LAN) on which machines such as the System Console and Cluster Console reside. Because normal users do not have access to the Administrative LAN, it provides an extra level of security. The use of an Administrative LAN is optional.

See also *public LAN*.

API

See *Application Program Interface*.

application (RMS)

A resource categorized as a `userApplication` used to group resources into a logical collection.

Application Program Interface

A shared boundary between a service provider and the application that uses that service.

application template (RMS)

A predefined group of object definition value choices used by the RMS Wizard Kit to create object definitions for a specific type of application.

attribute (RMS)

The part of an object definition that specifies how the base monitor acts and reacts for a particular object type during normal operations.

automatic switchover (RMS)

The procedure by which RMS automatically switches control of a `userApplication` over to another node after specified conditions are detected.

See also *directed switchover (RMS)*, *failover (RMS, SIS)*, *switchover (RMS)*, *symmetrical switchover (RMS)*.

availability

Availability describes the need of most enterprises to operate applications via the Internet 24 hours a day, 7 days a week. The relationship of the actual to the planned usage time determines the availability of a system.

base cluster foundation (CF)

This PRIMECLUSTER module resides on top of the basic OS and provides internal interfaces for the CF (Cluster Foundation) functions that the PRIMECLUSTER services use in the layer above.

See also *Cluster Foundation (CF)*.

base monitor (RMS)

The RMS module that maintains the availability of resources. The base monitor is supported by daemons and detectors. Each node being monitored has its own copy of the base monitor.

Cache Fusion

The improved interprocess communication interface in Oracle 9i that allows logical disk blocks (buffers) to be cached in the local memory of each node. Thus, instead of having to flush a block to disk when an update is required, the block can be copied to another node by passing a message on the interconnect, thereby removing the physical I/O overhead.

CCBR

See *Cluster Configuration Backup and Restore*.

CF

See *Cluster Foundation (CF)*.

child (RMS)

A resource defined in the configuration file that has at least one parent. A child can have multiple parents, and can either have children itself (making it also a parent) or no children (making it a leaf object).

See also *resource (RMS)*, *object (RMS)*, *parent (RMS)*.

cluster

A set of computers that work together as a single computing source. Specifically, a cluster performs a distributed form of parallel computing.

See also *RMS configuration*.

Cluster Admin

A Java-based, OS-independent management tool for PRIMECLUSTER products such as CF, RMS, PCS, and SIS. Cluster Admin is available from the Web-Based Admin View interface.

See also *Cluster Foundation (CF)*, *Reliant Monitor Services (RMS)*, *PRIME-CLUSTER Configuration Services (PCS)*, *Scalable Internet Services (SIS)*, *Web-Based Admin View*.

Cluster Configuration Backup and Restore

CBBR provides a simple method to save the current PRIMECLUSTER configuration information of a cluster node. It also provides a method to restore the configuration information.

Cluster Foundation (CF)

The set of PRIMECLUSTER modules that provides basic clustering communication services.

See also *base cluster foundation (CF)*.

cluster interconnect (CF)

The set of private network connections used exclusively for PRIMECLUSTER communications.

Cluster Join Services (CF)

This PRIMECLUSTER module handles the forming of a new cluster and the addition of nodes.

concatenated virtual disk (RCVM)

Concatenated virtual disks consist of two or more pieces on one or more disk drives. They correspond to the sum of their parts. Unlike simple virtual disks where the disk is subdivided into small pieces, the individual disks or partitions are combined to form a single large logical disk.

See also *mirror virtual disk (RCVM)*, *simple virtual disk (RCVM)*, *striped virtual disk (RCVM)*, *virtual disk*.

Configuration Definition Language (PCS)

The syntax for PCS configuration templates.

See also *PRIMECLUSTER Configuration Services (PCS)*.

configuration file (RMS)

The RMS configuration file that defines the monitored resources and establishes the interdependencies between them. The default name of this file is `config.us`.

console

See *single console*.

custom detector (RMS)

See *detector (RMS)*.

custom type (RMS)

See *generic type (RMS)*.

daemon

A continuous process that performs a specific function repeatedly.

database node (SIS)

Nodes that maintain the configuration, dynamic data, and statistics in a SIS configuration.

See also *gateway node (SIS)*, *service node (SIS)*, *Scalable Internet Services (SIS)*.

detector (RMS)

A process that monitors the state of a specific object type and reports a change in the resource state to the base monitor.

directed switchover (RMS)

The RMS procedure by which an administrator switches control of a userApplication over to another node.

See also *automatic switchover (RMS)*, *failover (RMS, SIS)*, *switchover (RMS)*, *symmetrical switchover (RMS)*.

distributing a configuration (RMS)

The process of copying a configuration file and all of its associated scripts and detectors to all nodes affected by the configuration. This is normally done automatically when the configuration is *activated* using PCS, the RMS Wizards, or the CLI.

See also *activating a configuration (RMS)*, *generating a configuration (RMS)*.

DOWN (CF)

A node state that indicates that the node is unavailable (marked as down). A LEFTCLUSTER node must be marked as DOWN before it can rejoin a cluster.

See also *UP (CF)*, *LEFTCLUSTER (CF)*, *node state (CF)*.

ENS (CF)

See *Event Notification Services (CF)*.

environment variables

Variables or parameters that are defined globally.

Glossary

error detection (RMS)

The process of detecting an error. For RMS, this includes initiating a log entry, sending a message to a log file, or making an appropriate recovery response.

Event Notification Services (CF)

This PRIMECLUSTER module provides an atomic-broadcast facility for events.

failover (RMS, SIS)

With SIS, this process switches a failed node to a backup node. With RMS, this process is known as switchover.

See also *automatic switchover (RMS)*, *directed switchover (RMS)*, *switchover (RMS)*, *symmetrical switchover (RMS)*.

gateway node (SIS)

Gateway nodes have an external network interface. All incoming packets are received by this node and forwarded to the selected service node, depending on the scheduling algorithm for the service.

See also *service node (SIS)*, *database node (SIS)*, *Scalable Internet Services (SIS)*.

GDS

See *Global Disk Services*.

generating a configuration (RMS)

The process of creating a single configuration file that can be distributed to all nodes affected by the configuration. This is normally done automatically when the configuration is *activated* using PCS, the RMS Wizards, or the CLI.

See also *activating a configuration (RMS)*, *distributing a configuration (RMS)*.

GFS

See *Global File Services*.

GLS

See *Global Link Services*.

Global Disk Services

This optional product provides volume management that improves the availability and manageability of information stored on the disk unit of the Storage Area Network (SAN).

Global File Services

This optional product provides direct, simultaneous accessing of the file system on the shared storage unit from two or more nodes within a cluster.

Global Link Services

This PRIMECLUSTER optional module provides network high availability solutions by multiplying a network route.

generic type (RMS)

An object type which has generic properties. A generic type is used to customize RMS for monitoring resources that cannot be assigned to one of the supplied object types.

See also *object type (RMS)*.

graph (RMS)

See *system graph (RMS)*.

graphical user interface

A computer interface with windows, icons, toolbars, and pull-down menus that is designed to be simpler to use than the command-line interface.

GUI

See *graphical user interface*.

high availability

A system design philosophy in which redundant resources are employed to avoid single points of failure.

See also *Reliant Monitor Services (RMS)*.

interconnect (CF)

See *cluster interconnect (CF)*.

Internet Protocol address

A numeric address that can be assigned to computers or applications.

See also *IP aliasing*.

Internode Communications facility

This module is the network transport layer for all PRIMECLUSTER internode communications. It interfaces by means of OS-dependent code to the network I/O subsystem and guarantees delivery of messages queued for transmission to the destination node in the same sequential order unless the destination node fails.

IP address

See *Internet Protocol address*.

IP aliasing

This enables several IP addresses (aliases) to be allocated to one physical network interface. With IP aliasing, the user can continue communicating with the same IP address, even though the application is now running on another node.

See also *Internet Protocol address*.

JOIN (CF)

See *Cluster Join Services (CF)*.

keyword

A word that has special meaning in a programming language. For example, in the configuration file, the keyword `object` identifies the kind of definition that follows.

leaf object (RMS)

A bottom object in a system graph. In the configuration file, this object definition is at the beginning of the file. A leaf object does not have children.

LEFTCLUSTER (CF)

A node state that indicates that the node cannot communicate with other nodes in the cluster. That is, the node has left the cluster. The reason for the intermediate LEFTCLUSTER state is to avoid the network partition problem.

See also *UP (CF)*, *DOWN (CF)*, *network partition (CF)*, *node state (CF)*.

link (RMS)

Designates a child or parent relationship between specific resources.

local area network

See *public LAN*.

local node

The node from which a command or process is initiated.

See also *remote node*, *node*.

log file

The file that contains a record of significant system events or messages. The base monitor, wizards, and detectors can have their own log files.

MDS

See *Meta Data Server*.

message

A set of data transmitted from one software process to another process, device, or file.

message queue

A designated memory area which acts as a holding place for messages.

Meta Data Server

GFS daemon that centrally manages the control information of a file system (meta-data).

mirrored disks (RCVM)

A set of disks that contain the same data. If one disk fails, the remaining disks of the set are still available, preventing an interruption in data availability.

See also *mirrored pieces (RCVM)*.

mirrored pieces (RCVM)

Physical pieces that together comprise a mirrored virtual disk. These pieces include mirrored disks and data disks.

See also *mirrored disks (RCVM)*.

mirror virtual disk (RCVM)

Mirror virtual disks consist of two or more physical devices, and all output operations are performed simultaneously on all of the devices.

See also *concatenated virtual disk (RCVM)*, *simple virtual disk (RCVM)*, *striped virtual disk (RCVM)*, *virtual disk*.

MMB

Abbreviation for Management Board, which is one of the hardware units installed in PRIMEQUEST.

mount point

The point in the directory tree where a file system is attached.

multihosting

Multiple controllers simultaneously accessing a set of disk drives.

native operating system

The part of an operating system that is always active and translates system calls into activities.

network partition (CF)

This condition exists when two or more nodes in a cluster cannot communicate over the interconnect; however, with applications still running, the nodes can continue to read and write to a shared device, compromising data integrity.

node

A host which is a member of a cluster. A computer node is the same as a computer.

node state (CF)

Every node in a cluster maintains a local state for every other node in that cluster. The node state of every node in the cluster must be either UP, DOWN, or LEFTCLUSTER.

See also *UP (CF)*, *DOWN (CF)*, *LEFTCLUSTER (CF)*.

object (RMS)

In the configuration file or a system graph, this is a representation of a physical or virtual resource.

See also *leaf object (RMS)*, *object definition (RMS)*, *object type (RMS)*.

object definition (RMS)

An entry in the configuration file that identifies a resource to be monitored by RMS. Attributes included in the definition specify properties of the corresponding resource. The keyword associated with an object definition is `object`.

See also *attribute (RMS)*, *object type (RMS)*.

object type (RMS)

A category of similar resources monitored as a group, such as disk drives. Each object type has specific properties, or attributes, which limit or define what monitoring or action can occur. When a resource is associated with a particular object type, attributes associated with that object type are applied to the resource.

See also *generic type (RMS)*.

online maintenance

The capability of adding, removing, replacing, or recovering devices without shutting or powering off the node.

operating system dependent (CF)

This module provides an interface between the native operating system and the abstract, OS-independent interface that all PRIMECLUSTER modules depend upon.

Oracle Real Application Clusters (RAC)

Oracle RAC allows access to all data in a database to users and applications in a clustered or MPP (massively parallel processing) platform. Formerly known as Oracle Parallel Server (OPS).

OSD (CF)

See *operating system dependent (CF)*.

parent (RMS)

An object in the configuration file or system graph that has at least one child.

See also *child (RMS)*, *configuration file (RMS)*, *system graph (RMS)*.

PCS

See *PRIMECLUSTER Configuration Services (PCS)*.

primary node (RMS)

The default node on which a user application comes online when RMS is started. This is always the nodename of the first child listed in the `userApplication` object definition.

PRIMECLUSTER Configuration Services (PCS)

The graphical configuration interface for PRIMECLUSTER products. PCS uses standard templates written in Configuration Definition Language (CDL) to provide a user-friendly configuration environment for products such as RMS. The standard templates can be modified or replaced to provide a customized interface for specific applications or installations.

PRIMECLUSTER services (CF)

Service modules that provide services and internal interfaces for clustered applications.

private network addresses

Private network addresses are a reserved range of IP addresses specified by the Internet Assigned Numbers Authority. They may be used internally by any organization but, because different organizations can use the same addresses, they should never be made visible to the public internet.

private resource (RMS)

A resource accessible only by a single node and not accessible to other RMS nodes.

See also *resource (RMS)*, *shared resource*.

public LAN

The local area network (LAN) by which normal users access a machine.

See also *Administrative LAN*.

queue

See *message queue*.

RC2000

Software (Java application) that provides functions for operating the operating system console of each node.

RCCU

Abbreviation for Remote Console Connection Unit.

See also *remote console connection unit*.

redundancy

This is the capability of one object to assume the resource load of any other object in a cluster, and the capability of RAID hardware and/or RAID software to replicate data stored on secondary storage devices.

Reliant Monitor Services (RMS)

The package that maintains high availability of user-specified resources by providing monitoring and switchover capabilities.

remote console connection unit

Device that converts an RS232C interface and a LAN interface. This device allows another device (personal computer) that is connected to the LAN to use the TTY console functions through the Telnet function.

remote node

A node that is accessed through a LAN or telecommunications line.

See also *local node*, *node*.

reporting message (RMS)

A message that a detector uses to report the state of a particular resource to the base monitor.

resource (RMS)

A hardware or software element (private or shared) that provides a function, such as a mirrored disk, mirrored disk pieces, or a database server. A local resource is monitored only by the local node.

See also *private resource (RMS)*, *shared resource*.

resource definition (RMS)

See *object definition (RMS)*.

resource label (RMS)

The name of the resource as displayed in a system graph.

resource state (RMS)

Current state of a resource.

RMS

See *Reliant Monitor Services (RMS)*.

RMS commands

Commands that enable RMS resources to be administered from the command line.

RMS configuration

A configuration made up of two or more nodes connected to shared resources. Each node has its own copy of operating system and RMS software, as well as its own applications.

RMS Wizard Kit

RMS configuration products that have been designed for specific applications. Each component of the Wizard Kit includes customized default settings, subapplications, detectors, and scripts. These application wizards also tailor the Wizard Tools or PCS interface to provide controls for the additional features.

See also *RMS Wizard Tools, Reliant Monitor Services (RMS)*.

RMS Wizard Tools

A software package composed of various configuration and administration tools used to create and manage applications in an RMS configuration.

See also *RMS Wizard Kit, Reliant Monitor Services (RMS)*.

SAN

See *Storage Area Network*.

Scalable Internet Services (SIS)

Scalable Internet Services is a TCP connection load balancer, and dynamically balances network access loads across cluster nodes while maintaining normal client/server sessions for each connection.

scalability

The ability of a computing system to dynamically handle any increase in work load. Scalability is especially important for Internet-based applications where growth caused by Internet usage presents a scalable challenge.

SCON

See *single console*.

script (RMS)

A shell program executed by the base monitor in response to a state transition in a resource. The script may cause the state of a resource to change.

service node (SIS)

Service nodes provide one or more TCP services (such as FTP, Telnet, and HTTP) and receive client requests forwarded by the gateway nodes.

See also *database node (SIS)*, *gateway node (SIS)*, *Scalable Internet Services (SIS)*.

shared resource

A resource, such as a disk drive, that is accessible to more than one node.

See also *private resource (RMS)*, *resource (RMS)*.

simple virtual disk (RCVM)

Simple virtual disks define either an area within a physical disk partition or an entire partition.

See also *concatenated virtual disk (RCVM)*, *striped virtual disk (RCVM)*, *virtual disk*.

single console

The workstation that acts as the single point of administration for nodes being monitored by RMS. The single console software, SCON, is run from the single console.

SIS

See *Scalable Internet Services (SIS)*.

state

See *resource state (RMS)*.

Storage Area Network

The high-speed network that connects multiple, external storage units and storage units with multiple computers. The connections are generally fiber channels.

striped virtual disk (RCVM)

Striped virtual disks consist of two or more pieces. These can be physical partitions or further virtual disks (typically a mirror disk). Sequential I/O operations on the virtual disk can be converted to I/O operations on two or more physical disks. This corresponds to RAID Level 0 (RAID0).

See also *concatenated virtual disk (RCVM)*, *mirror virtual disk (RCVM)*, *simple virtual disk (RCVM)*, *virtual disk*.

switchover (RMS)

The process by which RMS switches control of a userApplication over from one monitored node to another.

See also *automatic switchover (RMS)*, *directed switchover (RMS)*, *failover (RMS, SIS)*, *symmetrical switchover (RMS)*.

symmetrical switchover (RMS)

This means that every RMS node is able to take on resources from any other RMS node.

See also *automatic switchover (RMS)*, *directed switchover (RMS)*, *failover (RMS, SIS)*, *switchover (RMS)*.

system disk (GDS)

Disk on which the active operating system is installed. System disk refers to the entire disk that contains the slices that are currently operating as one of the following file systems (or the swap area):

For Solaris: /, /usr, /var, or swap area

For Linux: /, /usr, /var, /boot, /boot/efi, or swap area

system graph (RMS)

A visual representation (a map) of monitored resources used to develop or interpret the configuration file.

See also *configuration file (RMS)*.

template

See *application template (RMS)*.

type

See *object type (RMS)*.

UP (CF)

A node state that indicates that the node can communicate with other nodes in the cluster.

See also *DOWN (CF)*, *LEFTCLUSTER (CF)*, *node state (CF)*.

virtual disk

With virtual disks, a pseudo device driver is inserted between the highest level of the OS logical Input/Output (I/O) system and the physical device driver. This pseudo device driver then maps all logical I/O requests on physical disks.

See also *concatenated virtual disk (RCVM)*, *mirror virtual disk (RCVM)*, *simple virtual disk (RCVM)*, *striped virtual disk (RCVM)*.

Web-Based Admin View

A Java-based, OS-independent interface to PRIMECLUSTER management components.

See also *Cluster Admin*.

wizard (RMS)

An interactive software tool that creates a specific type of application using pretested object definitions. An enabler is a type of wizard.

Wizard Kit (RMS)

See *RMS Wizard Kit*.

Wizard Tools (RMS)

See *RMS Wizard Tools*.

Abbreviations

AC

Access Client

API

application program interface

bm

base monitor

CCBR

Cluster Configuration Backup/Restore

CDL

Configuration Definition Language

CF

Cluster Foundation or Cluster Framework

CIM

Cluster Integrity Monitor

CIP

Cluster Interconnect Protocol

CLI

command-line interface

CLM

Cluster Manager

CRM

Cluster Resource Management

DLPI

Data Link Provider Interface

ENS

Event Notification Services

Abbreviations

GDS	Global Disk Services
GFS	Global File Services
GLS	Global Link Services
GUI	graphical user interface
HA	high availability
ICF	Internode Communication Facility
I/O	input/output
JOIN	cluster join services module
LAN	local area network
MDS	Meta Data Server
MIB	Management Information Base
MIPC	Mesh Interprocessor Communication
MMB	Management Board
NIC	network interface card

NSM	Node State Monitor
OSD	operating system dependent
PAS	Parallel Application Services
PCS	PRIMECLUSTER Configuration Services
RCCU	Remote Console Connection Unit
RCFS	PRIMECLUSTER File Share
RCI	Remote Cabinet Interface
RCVM	PRIMECLUSTER Volume Manager
RMS	Reliant Monitor Services
SA	Shutdown Agent
SAN	Storage Area Network
SCON	single console software
SD	Shutdown Daemon
SF	Shutdown Facility

Abbreviations

SIS

Scalable Internet Services

VIP

Virtual Interface Provider

XSCF

eXtended System Control Facility

Figures

Figure 1:	Typical two-node cluster	10
Figure 2:	Cluster partition in two-node cluster	13
Figure 3:	Diagram of a typical PRIMECLUSTER setup	22
Figure 4:	PRIMECLUSTER framework overview	23
Figure 5:	MA normal operation	33
Figure 6:	MA operation in the event of node failure	34
Figure 7:	Node recovery	35
Figure 8:	Single cluster console configuration	41
Figure 9:	Distributed cluster console configuration	42
Figure 10:	RMS resource monitoring	44
Figure 11:	Example of a SIS cluster	45
Figure 12:	Disk Mirroring	47
Figure 13:	SAN (Storage Area Network)	48
Figure 14:	Operation continuation when a node is down	51
Figure 15:	NIC switching mode	54
Figure 16:	Typical four-node cluster	58
Figure 17:	RMS cluster on Solaris	68
Figure 18:	Configuration file interdependencies	72
Figure 19:	Base monitor interactions	76
Figure 20:	Wizard architecture	80
Figure 21:	SIS cluster with satellites nodes example	86
Figure 22:	SIS client/server illustration	87

Index

A

- administering
 - Cluster Admin 29
 - RMS 77
- allowing configuration changes 81
- applications
 - monitored resource 43
 - PAS 46
- assigning external connectivity 88
- attributes
 - mandatory 73
 - node 73
 - object properties 69
 - optional 73
- availability 24
 - design feature 25
 - high 10

B

- backup SIS database nodes 85
- bandwidth, interconnect 61
- base monitor
 - description 71
 - for central monitoring 71

C

- CF
 - See* Cluster Foundation
- CF/IP 57
- client-based algorithm 88
- cluster
 - architecture 21
 - partition 12
 - SIS 45
- Cluster Admin 26, 29
 - CF 29
 - RMS 77
- cluster consoles
 - multiple 40
 - SCON 40
 - software 40
 - See also* single console

- Cluster Foundation 26, 27, 30
 - Cluster Admin 29
 - driver 27
 - heartbeats 63
- cluster interconnect 11, 55
 - properties 60
 - reliability 64
 - sustained outage 55
 - See also* interconnects
- clusters 9
 - parallel databases 46
 - SIS 83
- configuration
 - allowing changes 81
 - copying 81
 - creating 81
 - file 71, 72
 - preventing changes 81
 - SCON 40
 - scripts 74
 - supporting additional 81
 - tools 26, 44, 72, 79, 80, 81, 82
 - wizards 26, 44, 72, 79, 80, 81, 82
- configuration tool foundation 81
- configuring
 - Cluster Admin 29
 - hub 56
- copying complete configuration 81
- creating RMS configuration 81
- customizing RMS 77

D

- data integrity, protecting 11, 25
- Data Link Provider Interface 64
- database nodes, SIS 85
 - and satellite nodes 86
- detectors 75
 - application specific 82
 - generic 77
- device and network access 22
- diagnostics services 29

Index

- distributed
 - computing 9
 - environment 18
- DLPI
 - See* Data Link Provider Interface
- documentation, related 2
- DOWN, state 60
- drivers
 - CF 27
 - network device 60
 - pseudo device 27
- duplexed network interface cards 53
- E**
- ENS
 - See* Event Notification Services
- environment variables 76
- Ethernets
 - error rate 64
 - fast 60
 - Gigabit 60
 - network availability 56
- Event Notification Services 29
- F**
- failover 70, 89
- features
 - availability 25
 - data integrity 25
 - scalability 25
- Fibre Channel controller 60
- file systems
 - high availability 51
 - mount points 69
 - network 43
 - update log 51
- files
 - cluster access 11
 - clusterwide system 25
 - configuration 71, 73, 77
 - custom 77
 - MIBs 30
 - RMS software 71
 - same source 27
 - user-specified configuration 70
- G**
- gateway nodes, SIS 85
 - and satellite nodes 86
- Gigabit Ethernet 60
- Global Disk Services 26
- Global File Services 27
- Global Link Services 27
 - NIC switching mode 53
 - redundant NICs 53
- GLS
 - See* Global Link Services
- guaranteed data integrity 24, 25
- H**
- heartbeats 55
 - request failures 59
 - requests 55, 63
 - responses 55
 - RMS 11
- high availability 10
 - clustering 9
 - file systems 51
 - multiple NICs 53
- host elimination 40
- hub, configure 56
- I**
- ICF
 - See* Internode Communication Facility
- installing aliases 81
- interconnects
 - bandwidth 61
 - fast switching mode 53
 - latency 63
 - NIC switching mode 53
 - non-symmetric 60
 - protocol 57
 - See also* cluster interconnect
- interface for cluster administration 26
- Internode Communication Facility 28, 57, 69

- IP aliasing 70
- J**
- join services (JOIN) 28
- K**
- keep local algorithm 88
- L**
- latency 63
- LEFTCLUSTER, state 60
- link recovery 60
- load-balancing algorithms 88
- M**
- Management Information Bases 30
- manual switchovers 70
- MCCU 40
- memory allocations 22
- MIBs
 - See* Management Information Bases
- modular components 26
- modularity 24
- monitoring
 - agent 17, 31
 - applications 11
 - components 11
- multiple network interface cards 53
- Multiport Console Connection Unit (MCCU) 40
- N**
- network interface cards
 - configuring 56
 - multiple 53
 - speeds 56
- networks
 - availability 56
 - configuring NIC 56
 - file systems 43
 - interfaces 43
- NIC switching mode 53
- NICs
 - See* network interface cards
- nodes
 - assigning weight 88
 - backup 89
 - client IP address 88
 - communication 89
 - definition 73
 - monitored resource 43
 - multiple proxy addresses 88
 - satellite, SIS 86
 - service 85
 - SIS database 85, 86
 - SIS database, backup 85
 - SIS gateway 85, 86, 87
 - type 73
- non-symmetric interconnects 60
- O**
- operating system dependant 27
- operations 29
- OSD
 - See* operating system dependant
- OS-independent interface 27
- P**
- Parallel Application Services 26
 - description 46
 - modularity 24
- PAS
 - See* Parallel Application Services
- path failure protection 53
- PCS Application Wizards 26, 44, 79, 80, 82
- PCS Wizards 26, 44, 72, 79, 80, 81
- platform independence 24
- preventing configuration changes 81
- primary SIS database nodes 85
- PRIMECLUSTER Configuration Services (PCS) 26, 44, 72, 79
- PRIMECLUSTER modules 26
- protecting data integrity 11, 25
- proxy addresses 88
- pseudo device driver 27

R

- RCA 40
- RCCU 40
- redundancy scheme 68
- redundant
 - cluster interconnect 58
 - components 10
- related documentation 2
- reliability, interconnects 64
- Reliant Monitor Services 30
- Remote Console Access (RCA) 40
- Remote Console Connection Unit (RCCU) 40
- resources
 - automatic switchover 70
 - detectors 75, 77
 - heartbeats 63
 - high availability 68
 - manual switchover 70
 - monitoring 74
 - states 74
 - switchover 69
- RMS 24, 26, 43
 - administering 77
 - configuration script 74
 - configuration tool foundation 81
 - configuration tool types 79
 - configuration tools 18, 26, 44, 72, 79, 80, 81, 82
 - detectors 82
 - environment variables 76
 - HA manager 11
 - overview 71, 76
 - PCS Application Wizards 26, 44, 79, 80, 82
 - PCS Wizards 26, 44, 72, 79, 80, 81
 - RMS Application Wizards 26, 44
 - RMS Wizard Kit 79, 80, 82
 - RMS Wizard Tools 26, 44, 72, 79, 80, 81
 - utility wizards 81
- round robin algorithm 88
- routers

- configuring 56
- latencies 64

S

- SAN
 - See* Storage Area Network
- SAP R/3 18
- satellite nodes, SIS 86
- scalability 9, 24
 - basic types of applications 18
 - network services 83
 - quantity of nodes 25
 - SIS 83
- scalable applications 19
- Scalable Internet Services 24, 45
 - architecture 26
 - description 45
 - network services 83
- scripts
 - optional attribute 73
 - RMS configuration 74
- service nodes, SIS 85, 89
- services
 - parallel application 46
 - scalable Internet 26
- Simple Network Management Protocol 26
- single console
 - configuration 41
 - software 40
 - See also* cluster consoles
- SIS
 - backup database nodes 85
 - gateway nodes 85
 - primary database nodes 85
 - satellite nodes 86
 - service nodes 85
- SMAWRscon 40
- spill over algorithm 88
- spin locks 22
- states
 - controlling changes 71
 - detectors 75
 - DOWN 60

- LEFTCLUSTER 60
 - monitoring changes 71
 - Offline 70
 - resources 74
 - scripts 75
 - UP 59
- Storage Area Network
 - high availability 10
 - wizards 81
- subagents 30
- sustained outage 55
- switchover 70
- synchronizations 22
- system load algorithm 88

U

- uninstalling aliases 81
- UP, state 59
- update log 51
- utility wizards 81

W

- Web-Based Admin View 26
- Weighted Connection Count
 - algorithm 88
- Windows 2000 Server, as satellite
 - node 86

