



PRIMECLUSTER™

Global Disk Services

Configuration and Administration Guide 4.1

(Linux)

January 2005

Contents

Chapter 1	Function.....	1
1.1	GDS Features.....	2
1.2	Functions for High Availability	4
1.2.1	Disk Mirroring	4
1.2.2	Hot Spare	7
1.2.3	Hot Swap.....	10
1.2.4	Just Resynchronization Mechanism (JRM).....	11
1.3	Functions for High Manageability.....	12
1.3.1	Operation Management Interface.....	12
1.3.2	Centralized Disk Management	13
1.3.3	Name Management.....	14
1.3.4	Single System Image Environment	15
1.3.5	Access Control	16
1.3.6	Realizing Large Capacity and I/O Load Balancing	19
1.3.7	Online Volume Expansion	22
1.3.8	Snapshots by Slice Detachment.....	24
1.4	GDS Snapshot Features	26
1.5	Proxy Volume	27
1.5.1	Snapshot by Synchronization.....	29
1.5.2	Snapshot Function with No Load to the server/SAN	33
1.5.3	Instant Snapshot by OPC.....	34
1.5.4	Instant Restore.....	35
1.5.5	Online Disk Migration	36
1.6	Shadow Volume.....	37
1.6.1	Accessing Volumes from an External Server.....	37
Chapter 2	Objects	39
2.1	SDX Object.....	40
2.2	Disk Class.....	41
2.3	SDX Disk	43
2.4	Disk Group.....	45
2.5	Logical Volume	47
2.6	Logical Slice	51
2.7	GDS Snapshot Objects	54
2.7.1	Proxy Object.....	54
2.7.2	Shadow Object.....	58
Chapter 3	Starting and Exiting GDS Management View	69
3.1	Preparation for Starting GDS Management View.....	70
3.1.1	Deciding the User Group.....	70
3.1.2	Setting up the Client Environment.....	71
3.1.3	Setting up the Web Environment.....	71
3.2	Starting the GDS Management View.....	72
3.2.1	Starting Web-Based Admin View Operation Menu	72
3.2.2	Web-Based Admin View Operation Menu Functions.....	73
3.2.3	Starting GDS Management View.....	74
3.3	Exiting GDS Management View	75
3.4	Changing the Web-Based Admin View Settings	76
Chapter 4	Management View Screen Elements.....	77
4.1	Screen Configuration.....	78
4.2	Menu Configuration and Functions	81
4.2.1	General	81
4.2.2	Settings	82
4.2.3	Operation	86
4.2.4	View.....	88

4.2.5	Help.....	88
4.3	Icon Types and Object Status.....	89
4.4	Object Information.....	92
Chapter 5	Operation.....	93
5.1	Operation Outline.....	94
5.1.1	Configuration Settings.....	95
5.1.2	Backup.....	97
5.1.3	Restore.....	100
5.1.4	Disk Swap.....	100
5.1.5	Disk Migration.....	101
5.1.6	Configuration Change.....	102
5.1.7	Operations from GDS Management View.....	103
5.2	Settings.....	106
5.2.1	Operating from the Settings Menu.....	106
5.2.2	File System Configuration.....	115
5.2.3	Proxy Configuration.....	117
5.3	Operation in Use.....	124
5.3.1	Viewing Configurations and Monitoring Statuses.....	125
5.3.2	Backup.....	134
5.3.3	Restore.....	147
5.3.4	Disk Swap.....	151
5.3.5	Disk Migration.....	155
5.3.6	Copying Operation.....	158
5.4	Changes.....	161
5.4.1	Class Configuration.....	161
5.4.2	Group Configuration.....	165
5.4.3	Volume Configuration.....	168
5.5	Removals.....	169
5.5.1	Removing a File System.....	169
5.5.2	Removing a Volume.....	170
5.5.3	Removing a Group.....	172
5.5.4	Removing a Class.....	173
5.5.5	Breaking a Proxy.....	174
Chapter 6	Backing Up and Restoring.....	177
6.1	Backing Up and Restoring Shared Disks.....	178
6.1.1	Offline Backup.....	178
6.1.2	Online Backup (by Slice Detachment).....	179
6.1.3	Restoring.....	180
6.2	Online Backup and Instant Restore through Proxy Volume.....	181
6.2.1	Online Backup (by Synchronization).....	183
6.2.2	Online Backup (Snapshot by OPC).....	186
6.2.3	Instant Restore.....	189
6.3	Backing Up and Restoring through an External Server.....	193
6.3.1	Backing Up and Restoring a Logical Volume with No Replication.....	195
6.3.2	Backing Up and Restoring through Snapshot by Slice Detachment.....	207
6.3.3	Backing Up and Restoring Using Snapshots from a Proxy Volume.....	221
Appendix	235
Appendix A	General Notes.....	237
A.1	Rules.....	237
A.1.1	Object Name.....	237
A.1.2	Number of Classes.....	238
A.1.3	Number of Disks.....	238
A.1.4	Number of Groups.....	238
A.1.5	Number of Volumes.....	238
A.1.6	Creating Group Hierarchy.....	239

A.1.7	Exception to Proxy Configuration	240
A.1.8	Number of Proxy Volumes.....	240
A.1.9	Proxy Volume Size	240
A.1.10	Proxy Group Size	240
A.2	Important Points	241
A.2.1	Managing System Disks	241
A.2.2	Restraining Access to Physical Special File	241
A.2.3	Booting from a CD-ROM Device	241
A.2.4	Initializing Disk.....	242
A.2.5	Disk Size	242
A.2.6	Volume Size	243
A.2.7	Hot Spare	243
A.2.8	Creating a Snapshot by Slice Detachment	245
A.2.9	The Difference between a Mirror Slice and a Proxy Volume	245
A.2.10	Just Resynchronization Mechanism (JRM)	245
A.2.11	Online Volume Expansion	247
A.2.12	Object Operation When Using Proxy.....	248
A.2.13	Using the Advanced Copy Function in a Proxy Configuration	249
A.2.14	Instant Snapshot by OPC	250
A.2.15	Ensuring Integrity of Snapshot Data	250
A.2.16	Data Consistency at the time of Simultaneous Access.....	251
A.2.17	Volume Access Mode	251
A.2.18	Operation in Cluster System.....	251
A.2.19	Disk Switch.....	251
A.2.20	Shadow Volume	251
A.2.21	GDS Management View	254
A.2.22	Upgrading Instructions	254
A.3	General Points.....	255
A.3.1	Guidelines for Mirroring	255
A.3.2	Guidelines for Striping	255
A.3.3	Guidelines for Concatenation	256
A.3.4	Guidelines for Combining Striping with Mirroring.....	256
Appendix B	Log Viewing with Web-Based Admin View.....	257
Appendix C	Web-Based Admin View Operating Environment Setting	259
Appendix D	Command Reference	261
D.1	sdxcass - Class operations.....	262
D.2	sdxdisk - Disk operations	263
D.3	sdxgroup - Group operations.....	269
D.4	sdxvolume - Volume operations	272
D.5	sdxslice - Slice operations	276
D.6	sdxinfo - Display object configuration and status information	279
D.7	sdxattr - Set objects attributes.....	289
D.8	sdxswap - Swap disk.....	294
D.9	sdxfix - Restore a failed object	296
D.10	sdxcopy - Synchronization copying operation	298
D.11	sdxparam - Configuration parameter operations.....	300
D.12	sdxproxy - Proxy object operations	302
D.13	sdxshadowdisk - Shadow disk operations.....	309
D.14	sdxshadowgroup - Shadow group operations.....	314
D.15	sdxshadowvolume - Shadow volume operations	317
D.16	Volume Creation Using Command.....	320
D.17	Snapshot Creation Using Command.....	324
Appendix E	GDS Messages	327
E.1	Web-Based Admin View Messages	327
E.2	Driver Messages.....	327

E.2.1	Warning Messages.....	328
E.2.2	Information Messages.....	331
E.2.3	Internal Error Messages.....	333
E.3	Daemon Messages.....	334
E.3.1	Halt Messages.....	335
E.3.2	Error Messages.....	336
E.3.3	Warning Messages.....	343
E.3.4	Information Messages.....	350
E.3.5	Internal Error Messages.....	361
E.4	Command Messages.....	362
E.4.1	Error Messages.....	363
E.4.2	Warning Messages.....	403
E.4.3	Information Messages.....	406
E.4.4	Fix Messages.....	413
E.4.5	Internal Error Messages.....	413
E.5	Operation Management View Messages.....	414
E.5.1	Error Messages.....	414
E.5.2	Warning Messages.....	417
E.5.3	Information Messages.....	422
Appendix F	Troubleshooting.....	429
F.1	Resolving Problems.....	429
F.1.1	Slice Status Abnormality.....	429
F.1.2	Disk Status Abnormality.....	435
F.1.3	Volume Status Abnormality.....	436
F.1.4	Class Status Abnormality.....	449
F.1.5	GDS Management View Abnormality.....	451
F.1.6	Cluster System Related Error.....	453
F.1.7	Shadow Object Errors.....	454
F.1.8	Disk Unit Error.....	455
F.2	Collecting Investigation Material.....	456
F.2.1	Collecting with pclsnap Command.....	456
F.2.2	Collecting Initial Investigation Material with sdxsnap.sh Script.....	456
Appendix G	Frequently Asked Questions (FAQ).....	457
G.1	Operation Design.....	457
G.2	Environment Configuration.....	459
G.3	Operation.....	459
Appendix H	Register shared disk units.....	461
H.1	Preparation to Use GDS.....	461
H.2	Registration of shared disk units.....	461
H.3	Registration procedure.....	461
H.4	Command Reference.....	464
H.4.1	clautoconfig(8)-Execute automatic resource registration.....	464
H.4.2	cldelrsc(8)-Delete resource created by automatic resource registration.....	465
Glossary	467

Preface

This manual describes the setting up and managing of GDS (Global Disk Services) and GDS Snapshot, an optional product of GDS, discussing the supported functions.

Purpose

This manual aims to help users understand GDS and GDS Snapshot, including environment configuration, operation and maintenance.

Target Reader

This manual is devoted to all users who will operate and manage GDS and GDS Snapshot and programmers who will create applications running in GDS environments.

Organization

This manual consists of 6 chapters, 7 appendices and a glossary.
The contents are as follows:

"YES" in the Operator or Administrator column indicates who would benefit from reading that portion.

	Contents	Operator	Administrator
Chapter 1 Functions	Explains the features of GDS and GDS Snapshot.	YES	YES
Chapter 2 Objects	Explains the objects used by GDS and GDS Snapshot.	YES	YES
Chapter 3 Starting and Exiting GDS Management View	Explains how to start and exit GDS Management and the required browser environment.	YES	YES
Chapter 4 Management View Screen Elements	Explains the contents of Management View.	YES	YES
Chapter 5 Operation	Explains the details about GDS operation such as operation flow, settings, maintenance and management.	YES	YES
Chapter 6 Backing Up and Restoring	Explains how to back up and restore data on disks managed by GDS.	YES	YES
Appendix A General Notes	Explains guidelines, general precautions, and configuration tips necessary for using GDS.	-	YES
Appendix B Log Viewing with Web-Based Admin View	For details, see the supplementary "Web-Based Admin View Operation Guide."	-	YES
Appendix C Web-Based Admin View Operating Environment Setting	For details, see the supplementary "Web-Based Admin View Operation Guide."	YES	YES
Appendix D Command Reference	Explains the commands available in GDS and GDS Snapshot.	-	YES
Appendix E GDS Messages	Explains the contents, possible causes, and resolutions for GDS messages that appear when setting or operating GDS and GDS Snapshot.	YES	YES
Appendix F troubleshooting	Explains resolutions for abnormality of objects and physical disks managed by GDS.	-	YES
Appendix G Frequently Asked Questions (FAQ)	Lists frequently asked questions regarding GDS and GDS Snapshot.	YES	YES
Appendix H Register shared disk units	Explains Registration shared disk units		
Glossary	Explains GDS and GDS Snapshot terminology. Please refer to it as necessary.	YES	YES

Related documentation

Please refer to the following documents according to need.

- PRIMECLUSTER Concepts Guide
- PRIMECLUSTER Installation and Administration Guide (for Linux)
- PRIMECLUSTER Cluster Foundation (CF) (Linux) Configuration and Administration Guide
- PRIMECLUSTER Reliant Monitor Services (RMS) with Wizard Tools Configuration and Administration Guide
- PRIMECLUSTER Web-Based Admin View Operation Guide
- PRIMECLUSTER Global File Services Configuration and Administration Guide (Linux)





Manual Printing

Use the PDF file supplied in the product CD-ROM to print this manual.

Adobe Acrobat Reader Version 4.0 or higher is required to read and print this PDF file.

Symbol

The following conventions are used in this manual:

-  **Point** Main points are explained.
-  **Note** Items that require attention are explained.
-  **Information** Useful information is given.
-  **See** Manual names and sections of this manual you should refer to are given.

Abbreviated name

- Microsoft(R) Windows NT(R) Server operating System Version4.0 and Microsoft(R) Windows NT(R) Server workstation System Version4.0 are abbreviated as Windows NT(R).
- Microsoft(R) Windows(R) 95 operating system is abbreviated as Windows(R) 95.
- Microsoft(R) Windows(R) 98 operating system and Microsoft(R) Windows(R) 98 Second Edition operating system are abbreviated as Windows(R) 98.
- Microsoft(R) Windows(R) 2000 operating system is abbreviated as Windows(R) 2000.
- Microsoft(R) Windows(R) Millennium Edition is abbreviated as Windows(R) Me.
- Microsoft(R) Windows(R) XP operating system is abbreviated as Windows(R) XP.
- Windows(R) 95, Windows(R) 98, Windows NT(R), Windows(R) 2000, Windows(R) Me and Windows(R) XP are abbreviated as Microsoft(R) Windows.

January 2005

Trademarks

Netscape and Netscape Navigator are trademarks of Netscape Communications Corporation.

Microsoft is a registered trademark of Microsoft Corporation in the United States and other countries.

Microsoft, Windows, Windows NT, Windows Me, Internet Explorer, and Windows 2000 are registered trademarks of Microsoft Corporation in the United States and other countries.

Linux is a registered trademark or a trademark of Linus Torvalds in the United States and other countries.

All Red Hat, RPM, and Red Hat based trademarks and logos are registered trademarks of Red Hat, Inc. in the United States and other countries.

Java and all Java based-marks and logos are trademarks or registered trademarks of Sun Microsystems, Inc. in the United States and other countries.

PRIMECLUSTER is a trademark of Fujitsu LIMITED.

Other product names that appear in this manual are product names, trademarks, or registered trademarks of respective companies.

Notice

- No part of this manual may be reproduced without permission.
- This manual is subject to change without advance notice.

All Rights Reserved, Copyright(C) 2005 Fujitsu LIMITED.

All Rights Reserved, Copyright(C) 2005 Fujitsu Siemens Computers GmbH.

Chapter 1 Function

This chapter describes the features and functions of GDS (Global Disk Services) and GDS Snapshot.

1.1 GDS Features

GDS is volume management software that improves the availability and manageability of disk-stored data. GDS protects disk data from hardware failures and operational mistakes and supports the management of disk units.

GDS has the following functions, which are closely related:

- To improve availability of disk data
- To improve manageability of disk data

GDS's mirroring function protects data from hardware failures by maintaining replicas of disk data on multiple disks. This allows users to continue to access disk data without stopping the application in the event of unexpected trouble.

Figure: Mirroring of Disk Units

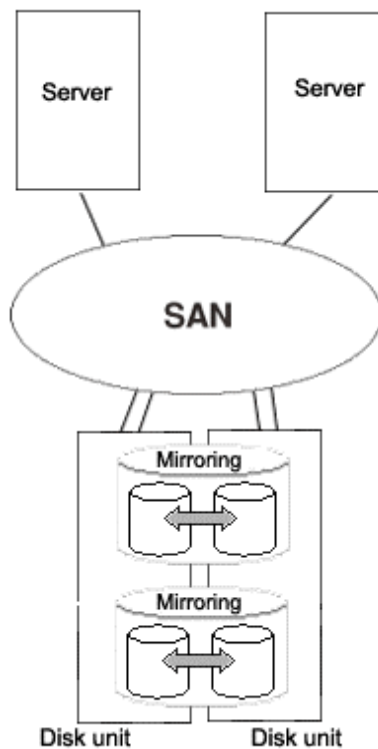
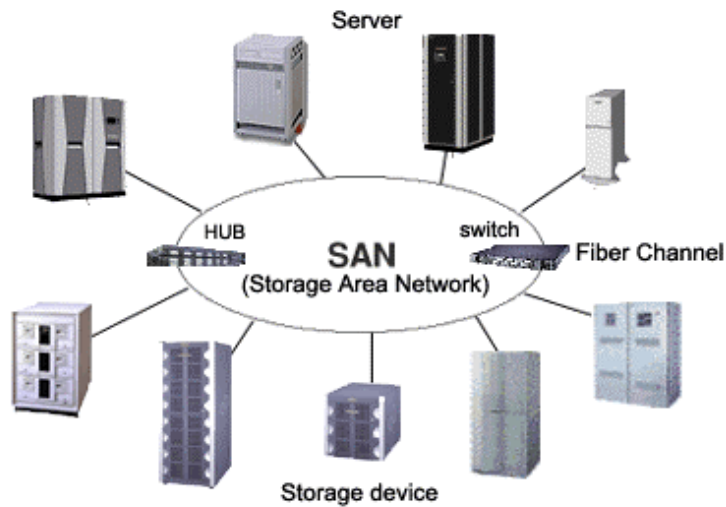

Figure: SAN (Storage Area Network)



GDS consolidates the management of all disk units that are shared between multiple servers configuring a PRIMECLUSTER system on a SAN (Storage Area Network).

Multiple servers can be connected to multiple disk units in a SAN environment. Disk-stored data can be accessed from those servers. This allows simultaneous access to file systems or databases and improves the efficiency of data duplication between the servers and backup procedures. On the other hand, it also carries the risk of data damage, as multiple servers will compete to access the shared disk. Therefore, volume management functions suitable for the SAN environment are essential.

Since GDS's management function is suitable for a SAN environment, advanced system operation for disk management can be performed with ease.

The user-friendly functions simplify management, and at the same time, prevent data corruption by operational mistakes.

Figure: Access Control Mechanism in a SAN Environment

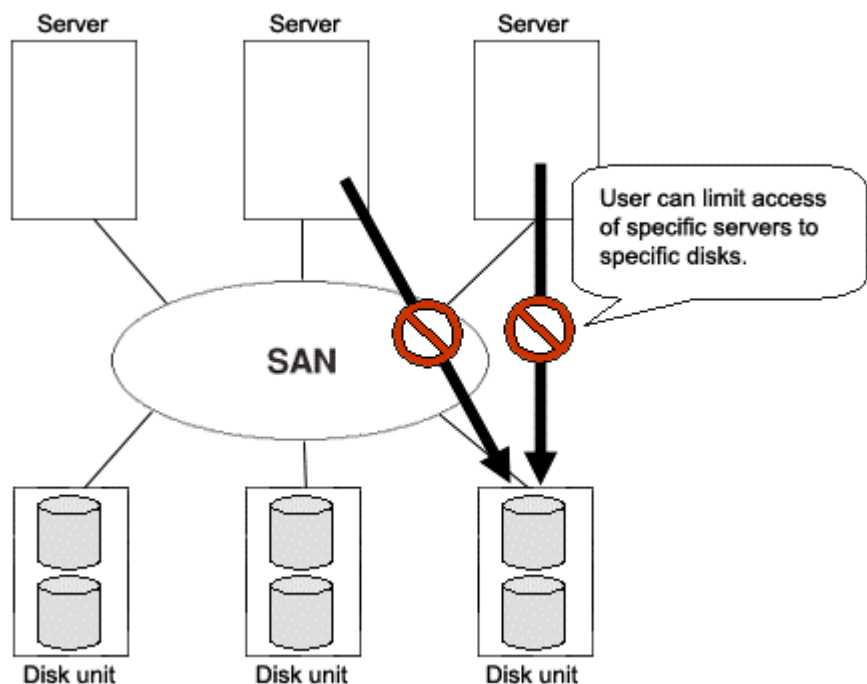

1.2 Functions for High Availability

Failure of hardware related to disk unit interrupts data access, causing applications or systems to stop. In this section, functions which protect data from unexpected hardware problems, and improve system availability are explained.

1.2.1 Disk Mirroring

Disk mirroring utilizes multiple disks in order to maintain data synchronization.

GDS realizes disk mirroring by creating one logical disk from multiple physical disks. Disk mirroring allows applications to access a different disk even if one mirror disk (a disk that is mirrored) fails. Therefore, data will not be damaged and the applications will continue normal operation.

Figure: Disk Mirroring

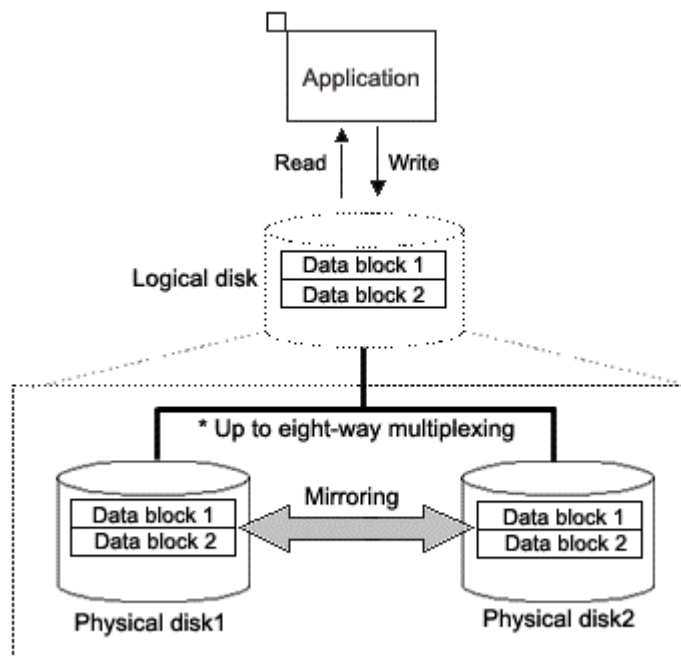

GDS supports mirroring of a single disk unit (JBOD) and mirroring of disk arrays.

Some examples of special mirroring implementation are explained below.

1.2.1.1 Mirroring between Disk Array Unit

GDS realizes high-performance, high-reliability mirroring of disk arrays.

Mirroring two disk arrays connected with Fibre Channel provides data protection from unexpected accidents and blackouts. Also, by combining this feature with special software, disk units with redundant access paths can also be mirrored.

Figure: Mirroring between Disk Array Unit

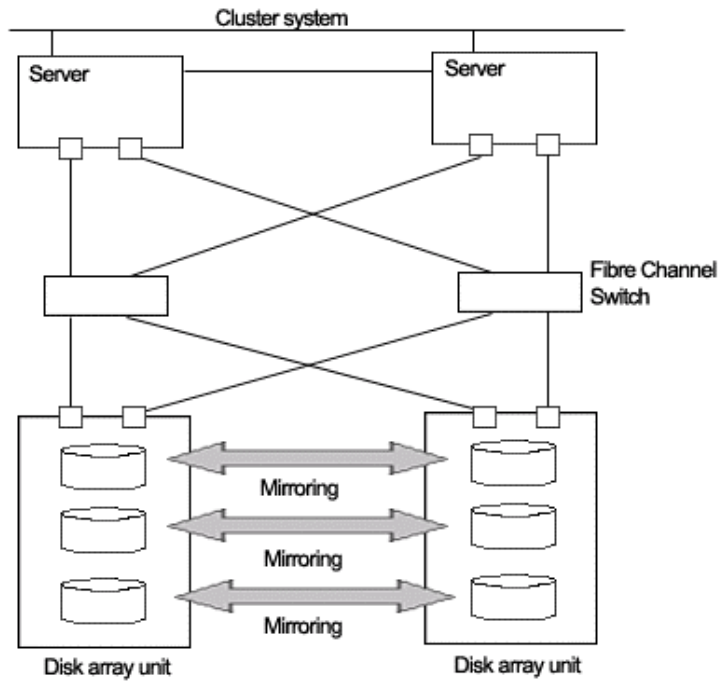

1.2.1.2 Shared Disk Mirroring

GDS provides a function that mirrors shared disk units connected a cluster system composed of multiple servers (also referred to as nodes).

This is called shared disk mirroring in distinction from local disk mirroring that mirrors disks connected to a single node.

The GDS's shared disk mirroring function can be used with applications, such as the GFS Shared File System, that provide simultaneous access from multiple servers to shared disks, not to mention switch-over or standby type applications.

Figure: Shared Disk Mirroring

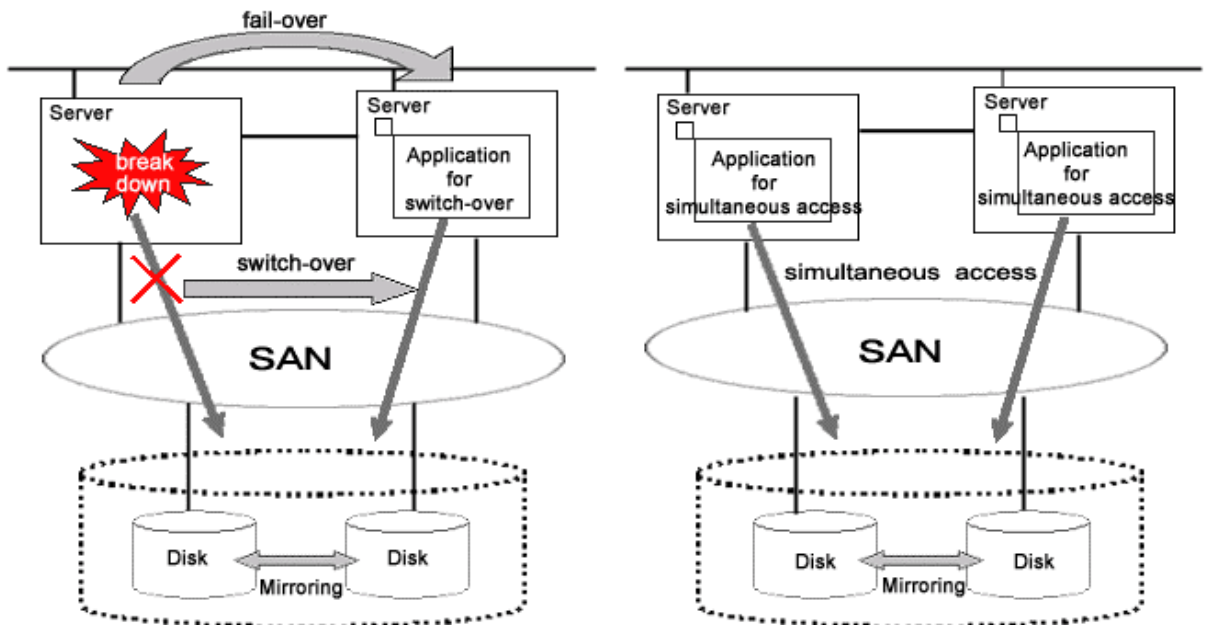

1.2.2 Hot Spare

Overview

"hot spare" is a feature that realizes automatic mirroring recovery using spare disks in the event of mirrored disk failure.

Figure: Hot Spare

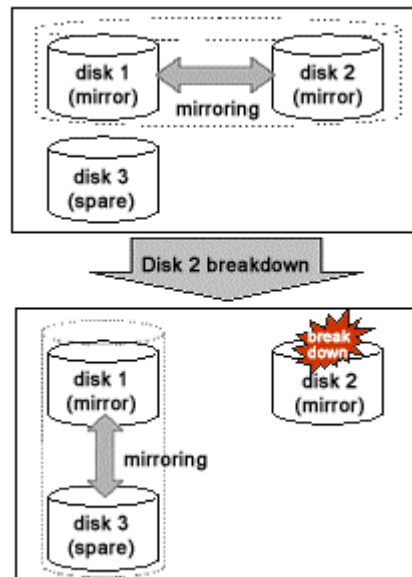

Spare Disk Automatic Connection

If an I/O error occurs in a disk connected to a mirror group, a spare disk is automatically connected to the mirror group. Subsequently, synchronization copying for the spare disk takes place and the mirroring status will be restored.

Spare Disk Automatic Disconnection

After the disk where an I/O error occurred is recovered, the spare disk is automatically disconnected from the mirror group. For example, if disk failure causes an I/O error and a spare disk is automatically connected, after the failed disk is swapped with another disk and synchronization copying to the new disk is complete, the spare disk will automatically be disconnected.

Hot Spare Mode (Spare Disk Selection Mode)

A spare disk automatically connected in the event of I/O error in a mirrored disk is selected from spare disks that are registered with the failed disk's class. There are two modes of selecting spare disks: external mode and internal mode.

- **External Mode (Default)**

If an I/O error occurs in a disk of a disk array unit, this method selects a spare disk that belongs to a different disk case from that of the failed disk.

If an I/O error occurs in a disk irrelevant to a disk array unit, it selects a spare disk that is connected to a different controller from that of the failed disk.

When no applicable unconnected spare disk is found there, a spare disk that belongs to the same disk case or is connected to the same controller as that of the disk with the I/O error is selected.

Features:

If an I/O error occurs in a disk, the I/O cable of the disk case may cause an error, the entire disk case may be down, or the controller may have a breakdown. By searching for a spare disk starting from a different disk case or controller from that of a disk with an I/O error, a normal spare disk can promptly be found and early mirroring recovery becomes possible.

Figure: Hot Spare in External mode

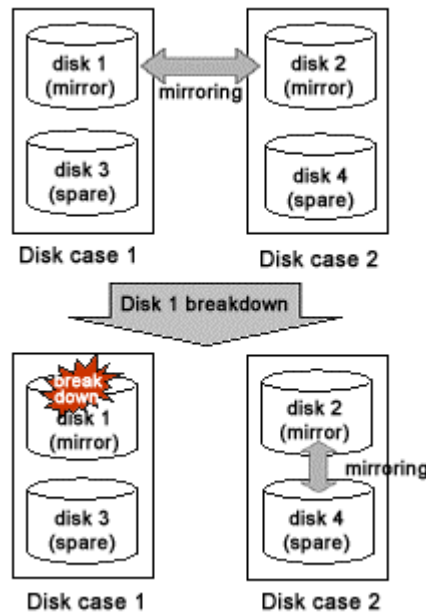

- **Internal Mode**

If an I/O error occurs in a disk of a disk array unit, this method selects a spare disk that belongs to the same disk case as that of the failed disk.

If an I/O error occurs in a disk irrelevant to a disk array unit, it selects a spare disk that is connected to the same controller as that of the failed disk.

When no applicable unconnected spare disk is found there, spare disk automatic connection is not performed.

Features:

A configuration that mirrors disks belonging to different disk unit cases or connected to different controllers is the configuration with high-availability, which secures continuous operations even if one of the disk cases or controllers fails. By selecting a spare disk that belongs to the same disk case or is connected to the same controller as that of the disk with an I/O error, the configuration with high-availability can be maintained.

Chapter 1-1 Figure: Hot Spare in Internal Mode

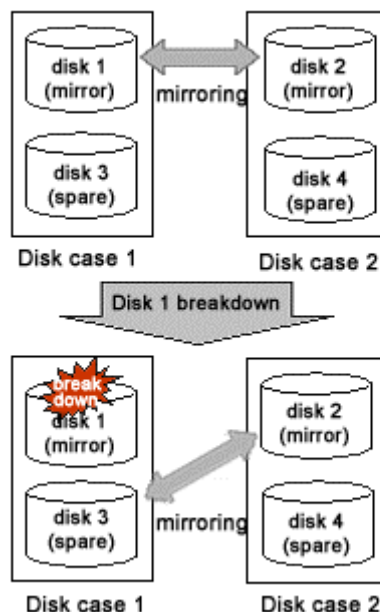

Setting Methods

- **Registering a spare disk**

When registering a disk with a class, set the disk type attribute to "spare".



See

- For spare disk registration methods, see "5.2.1.1 Class Configuration" when using the GDS Management View, or the description about the -M option in "D.2 sdxdisk - Disk operations" when using the command.
- For disk type changing methods, see "Changing the Disk Attributes" in "5.4.1 Class Configuration" when using the GDS Management View, or the description about the -D option in "D.7 sdxattr - Set objects attributes" when using the command.

- **Setting the hot spare mode**

If a class is created through the GDS Management View, the hot spare mode attribute of the class is set to external mode. To change this attribute, use the sdxattr -C command. If a class is created through the command, the hot spare mode attribute is selectable at the creation time.



See

- For hot spare mode setting methods, see the description about the -M option in "D.2 sdxdisk - Disk operations."
- For hot spare mode changing methods, see "D.7 sdxattr - Set objects attributes."
- For the hot spare mode value, use the sdxinfo -e long command and check the HSMODE field of displayed class information.
For details, see "D.6 sdxinfo - Display object configuration and status information."

- **Disabling hot spare**

If the class's hot spare attribute is set to "off", hot spare is disabled for the class. To change the hot spare attribute, use the sdxattr -C command. If a class is created through the command, the hot spare mode attribute is selectable at the creation time.



See

- For hot spare mode setting methods, see the description about the -M option in "D.2 sdxdisk - Disk Operations."
- For hot spare mode changing methods, see "D.7 sdxattr - Set objects attributes."
- For the hot spare attribute value, use the sdxinfo -e long command and check the HS field of the displayed class information. For details, see "D.6 sdxinfo - Display object configuration and status information."



Note **Points of Concern for Hot Spare**

See "A.2.7 Hot Spare."

1.2.3 Hot Swap

Hot swap allows exchange of faulty disk unit parts without stopping the application in the event of a mirror disk failure. With GDS, administrator does not have to be aware of the system configuration. The system configuration is transparent to the administrator. Therefore, the administrator can simply select a failed disk displayed in the GUI window to conduct preparation before swapping disks and restoration through mirroring after the swapping. If a spare disk has been operating in place of the defective disk unit, the spare disk will disconnect automatically, returning to its original state.

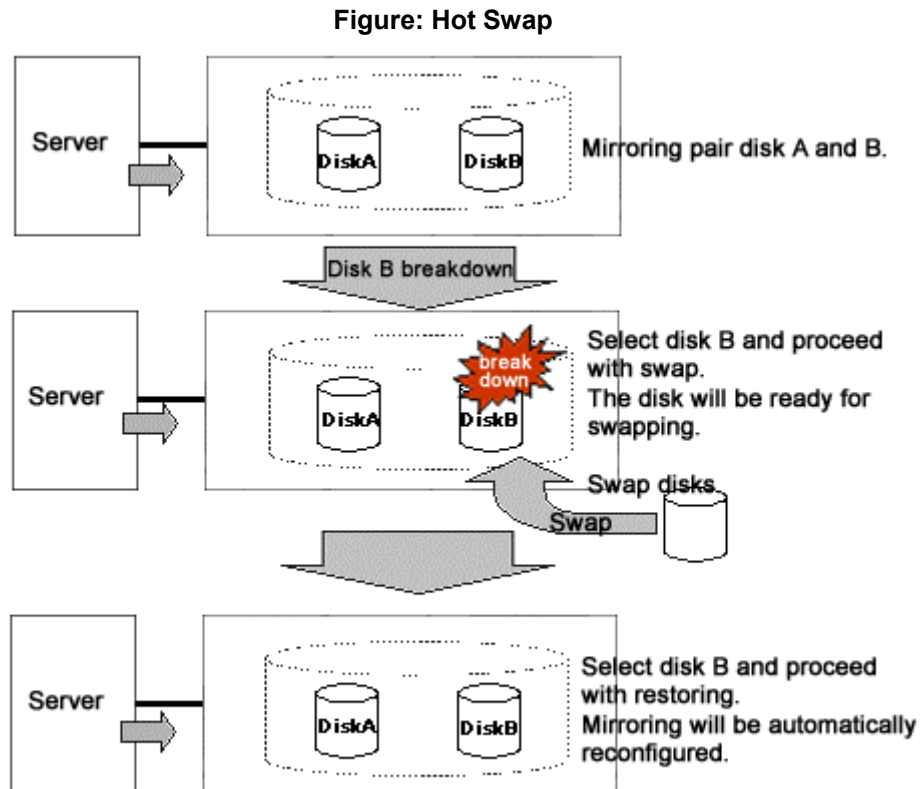

Note **Conditions for Hot Swap**

GDS's function for hot swapping is available only when using a disk unit supporting hot swapping. Do not remove or insert a disk when using a disk unit not supporting hot swapping. It may cause breakdown, or damage data.

1.2.4 Just Resynchronization Mechanism (JRM)

When a system is down due to panic and so on, data must be resynchronized between the disk units after reboot (after cluster application failover for a cluster system). Although the user can run an application during this copying process, redundancy will be lost and loads will be imposed during the process.

In order to resolve this problem GDS offers a mechanism called Just Resynchronization Mechanism (JRM). JRM completes copying, which usually takes a few minutes for every 1GB, in no time by copying only portions where mirroring synchronization is no longer retained.

Figure: Just Resynchronization Mechanism(JRM)

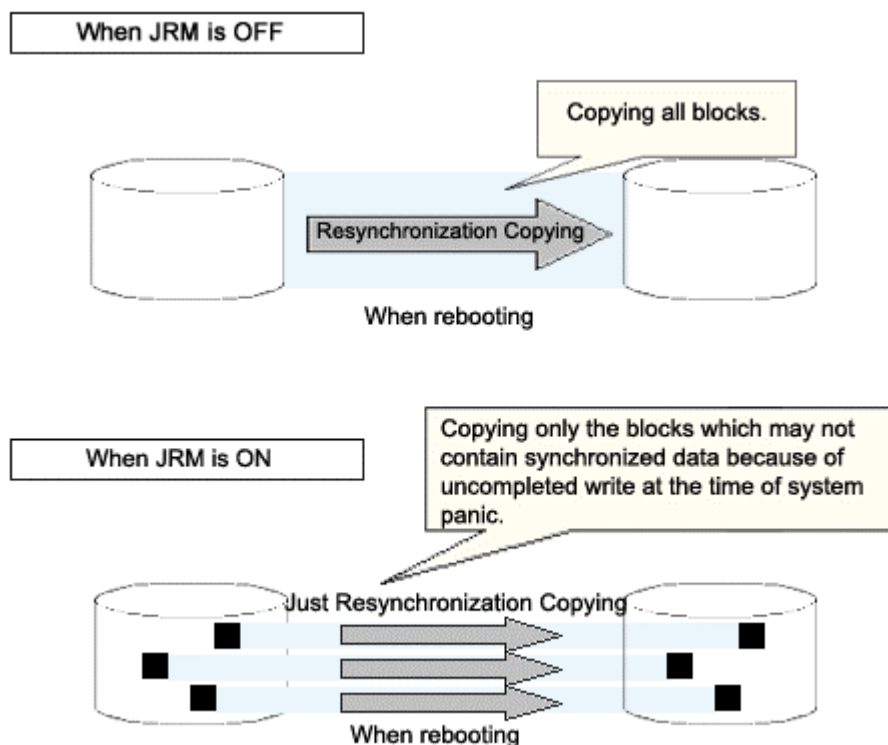

Information **What is JRM?**

JRM stands for Just Resynchronization Mechanism, a feature that only allows duplication of the damaged part of data.



Information **Three Types of JRM**

There are three types of Just Resynchronization Mechanism (JRM): for volumes, for slices and for proxy. For details, see "A.2.10 Just Resynchronization Mechanism (JRM)."

1.3 Functions for High Manageability

GDS supports various tasks related to disk management, such as installation, operation, and maintenance.

Efficient management functions are essential especially in a SAN environment, where one disk is directly shared with multiple servers.

Functions improving disk manageability are explained below.

1.3.1 Operation Management Interface

By registering a disk unit with GDS, system administrators will be able to centrally manage all operation on the disk (configuration setting, configuration management, operation monitoring, backup, data migration, configuration change, maintenance) via GDS operation management interface.

Operation management interface provides the GUI (Graphical User Interface), automatic processing, operation log, and CLI (Command Line Interface) useful for liaising with other applications, allowing easy and intuitive operation even for inexperienced Linux system users.

Since the GUI is Web browser-based, system administrator will be able to centrally monitor and operate from any remote location.

Figure: Operation Management Interface

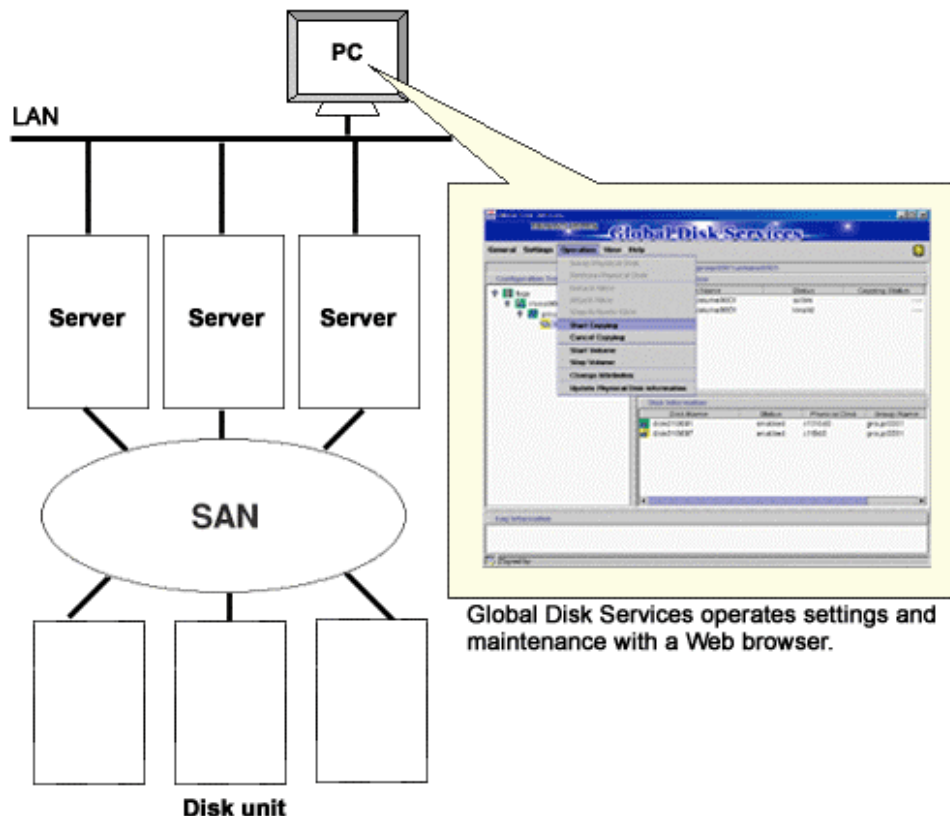

See

For the operation methods of the GUI, see "Chapter 3 Starting and Exiting GDS Management View," "Chapter 4 Management View Screen Elements," and "Chapter 5 Operation."

For the usage methods of CLI, see "Appendix D Command Reference."

For the operations available on GUI and on CLI, see "5.1.7 Operations from GDS Management View."

1.3.2 Centralized Disk Management

By registering all shared disk units connected to the server with GDS, the system administrator will be able to centrally manage all operations on the disk via GDS's operation management interface.

Since disk units managed by GDS are virtualized as logical volumes, there is no need for the application to handle physical disks.

Various disks can be managed centrally, without regard to the physical configuration (single disk, disk array, multi path) and the intended use (switch-over disk for cluster, concurrent shared disk for cluster). Whether or not to mirror the managed disk can be determined as necessary. For example, a user may want to manage a disk array with sufficient availability, without carrying out mirroring.

Figure: Central Management of Disks

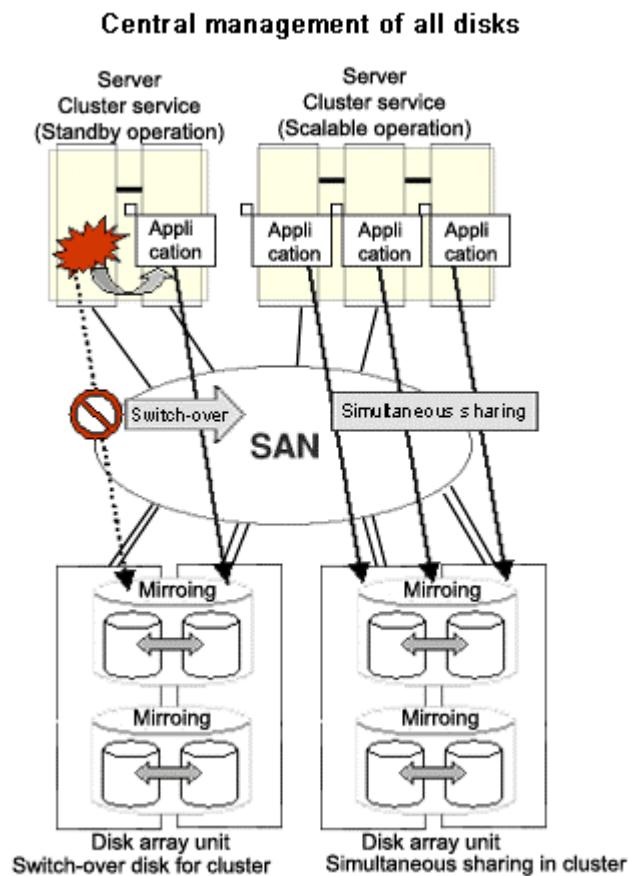

1.3.3 Name Management

In Linux System, disks are named in "sdX" format, where "X" is an alphabetical character assigned by the OS, and the administrator differentiates the disks by the assigned consecutive characters.

This was not a problem if the disk configuration was small, and if the disks were accessed from a certain server. However, when the environment is such that there are many disks connected, or in a SAN environment where a disk is shared by multiple servers, it is impossible to manage the disks using consecutive numbers.

With GDS, the administrator can freely name objects such as physical disks and logical volumes.

Names that are easy to remember, for example, those associated with hardware configuration or data contents can be assigned. Once an object is named, the name remains the same even if the physical configuration is changed. In other words, the user does not have to make any changes to applications that recognize the name.

Figure: Free Device Name

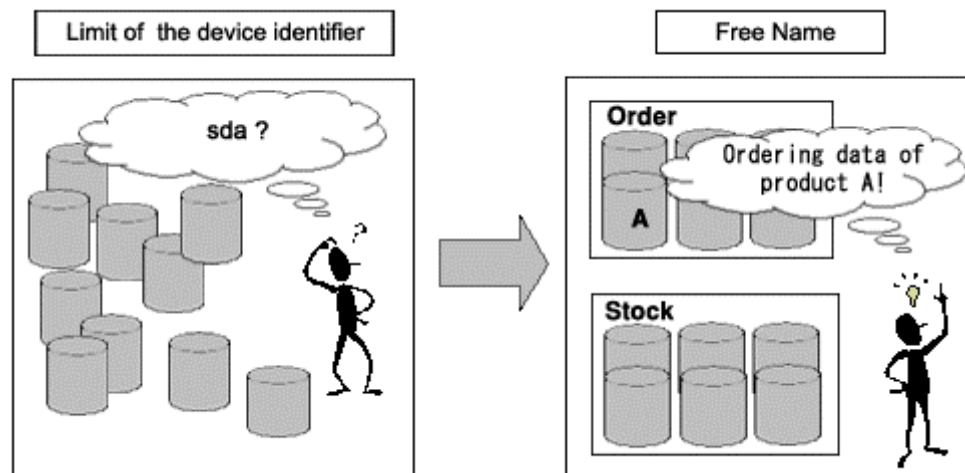

1.3.4 Single System Image Environment

In a SAN environment, a disk unit can be accessed from multiple servers. GDS provides a single system image environment, in which a cluster system with multiple servers (also referred to as nodes) appears as one system to the users or application.

This single system image environment can be utilized as explained below.

- Application programs sharing the same disk can lookup disks and volumes using the same name from all nodes.
- Application programs can access the disk simultaneously from all nodes. For details, see “Note.”
- Application programs can perform operations from all nodes, such as changing the configuration on objects (such as disks and volumes). Changes are reflected on all nodes.

Figure: Single System Image Environment

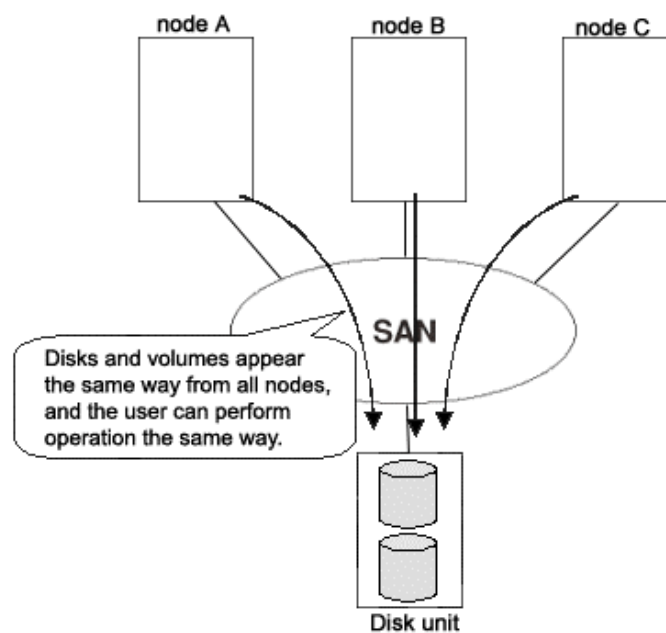

Note Access Exclusion Control

When the same block is accessed simultaneously, data consistency is maintained by access exclusion control performed by the application that runs on multiple nodes simultaneously.

1.3.5 Access Control

GDS provides the following access control functions to prevent data damage from events such as an improper operation by the user.

Class Scope

In order to manage a disk unit with GDS, it must be registered with a certain class.

A class is like a container that holds multiple disks.

By defining the class attribute called "scope", the user can specify which node set has access, or can perform operation on the disks registered to that class. Since operation on the disk is restricted to the nodes you specify, there is no risk of changing the configuration by mistake, or losing data consistency.

Suppose there are disks connected to two nodes; node A and B. The administrator wants node A to have access to some of the disks, while node B has access to the remaining disks.

In this case, two classes should be created to separately manage the disks shared by node A and B. This ensures that access by the node that is not selected in the class scope is restricted.

Figure: Class Scope

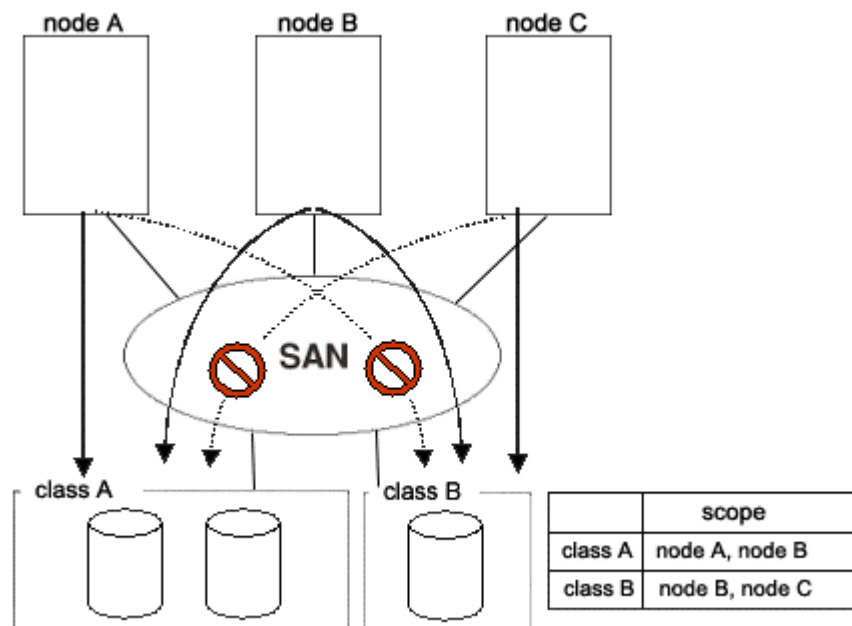

Starting and Stopping Volume

GDS's logical volume can be started or stopped for each node sharing the volume.

Since a stopped volume cannot be accessed from the node, there is no risk of losing data consistency by mistake.

Figure: Starting and Stopping Volume

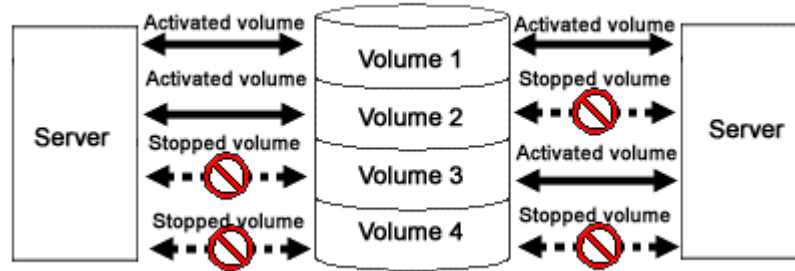

Access Mode

Logical volume has an attribute called "Access mode", which can be defined for each node sharing the volume. There are two access modes; "Read and write possible" mode, and "Read only possible" mode. For example, if a certain node will access the logical volume to create data backup, set the mode "Read only possible". That way, you can prevent writing to the volume by mistake.

Figure: Access Mode

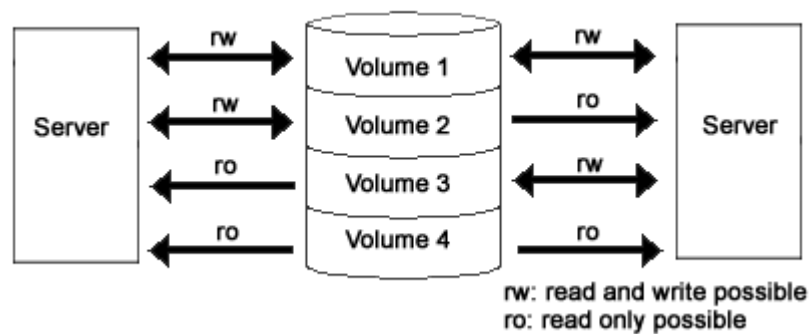

Lock Volume

When the node or cluster application is activated, logical volume starts automatically and becomes accessible. Likewise, when the cluster application is terminated, logical volume will also stop. This prevents a node with terminated application from accessing the logical volume. However, rebooting a node could result in starting the volume. In order to preclude the logical volume from starting in such a situation, the user can define the "Lock volume" attribute. When "Lock volume" is selected, volume will not be activated even when the node is rebooted, or cluster application activated.

Figure: Lock Volume

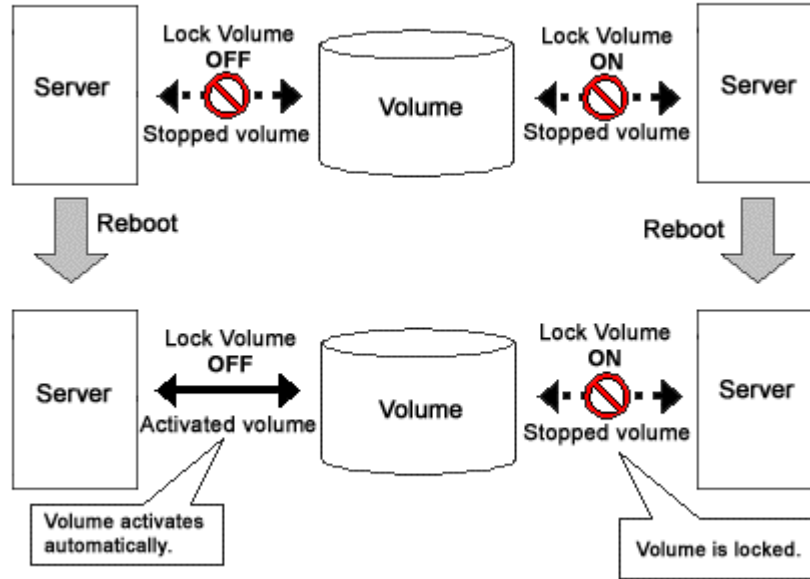

1.3.6 Realizing Large Capacity and I/O Load Balancing

In our current SAN environment, the demand for large capacity disk units and the amount I/O data processing is increasing daily.

This sub-section describes the functions that realize flexible disk configuration and I/O load balancing for efficient management of large volumetric data.

1.3.6.1 Logical Partitioning

Logical partitioning divides a physical disk into logical devices based on its original method, and not based on the disk slice management provided by the partition table.

With an external disk (physical disk) in a Linux system, in general, a maximum of 16 partitions can only be used.

GDS allows users to use physical disks and objects equivalent to disks dividing them into a maximum of 224 logical devices.

For details, see "2.5 Logical Volume" and "D.4 sdxvolume - Volume operations."

1.3.6.2 Disk Concatenation

Disk concatenation combines multiple physical disks to form a single, large logical disk.

By using the disk concatenation function, users are able to configure a large-capacity logical disk device without being restricted to the limitation of one physical disk.

Figure: Disk Concatenation

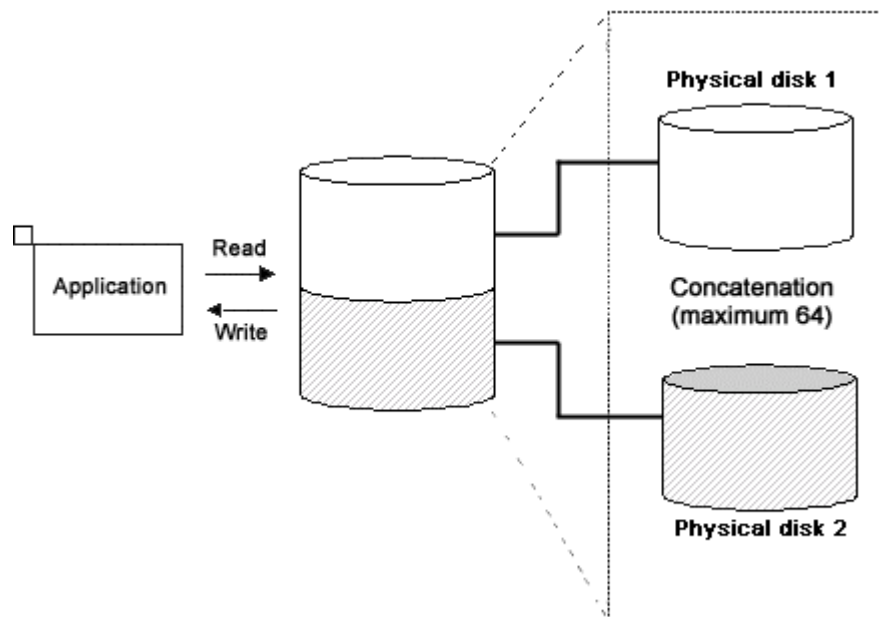

1.3.6.3 Disk Striping

Disk striping maps equal-sized data units on multiple disks so that the data is interleaved in sequence among two or more physical disks.

Disk striping function can balance the I/O load by distributing the divided I/O requests to multiple physical disks simultaneously.

You can also stripe concatenated disks.

Figure: Disk Striping

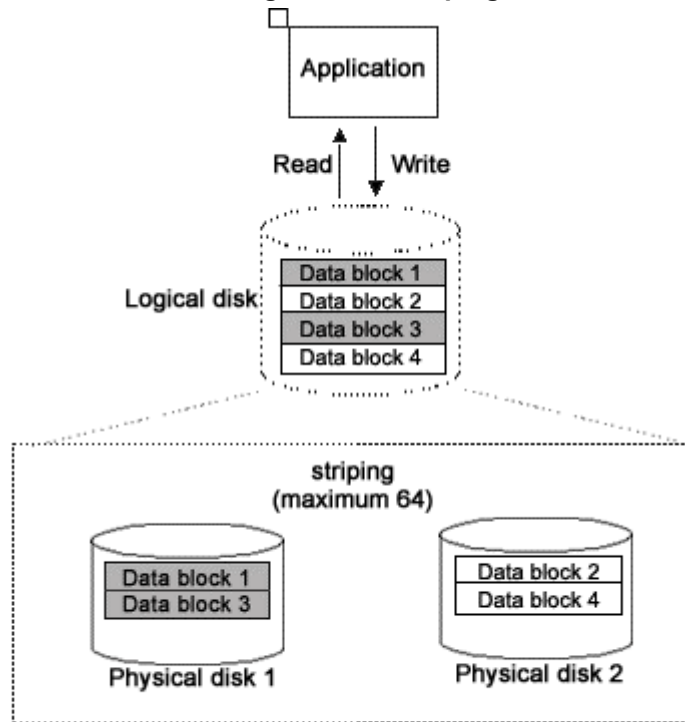

1.3.6.4 Combining Disk Striping with Mirroring

Concatenation and striping does not provide data redundancy. Since it involves more disks compared to a usual disk configuration, the risk of data loss caused by a disk failure is actually larger.

GDS delivers data redundancy as well as high-capacity storage and I/O load distribution by mirroring concatenated or striped disks.

When using concatenation or striping, you are recommended to use mirroring as well.

Figure: Combining Striping and Mirroring

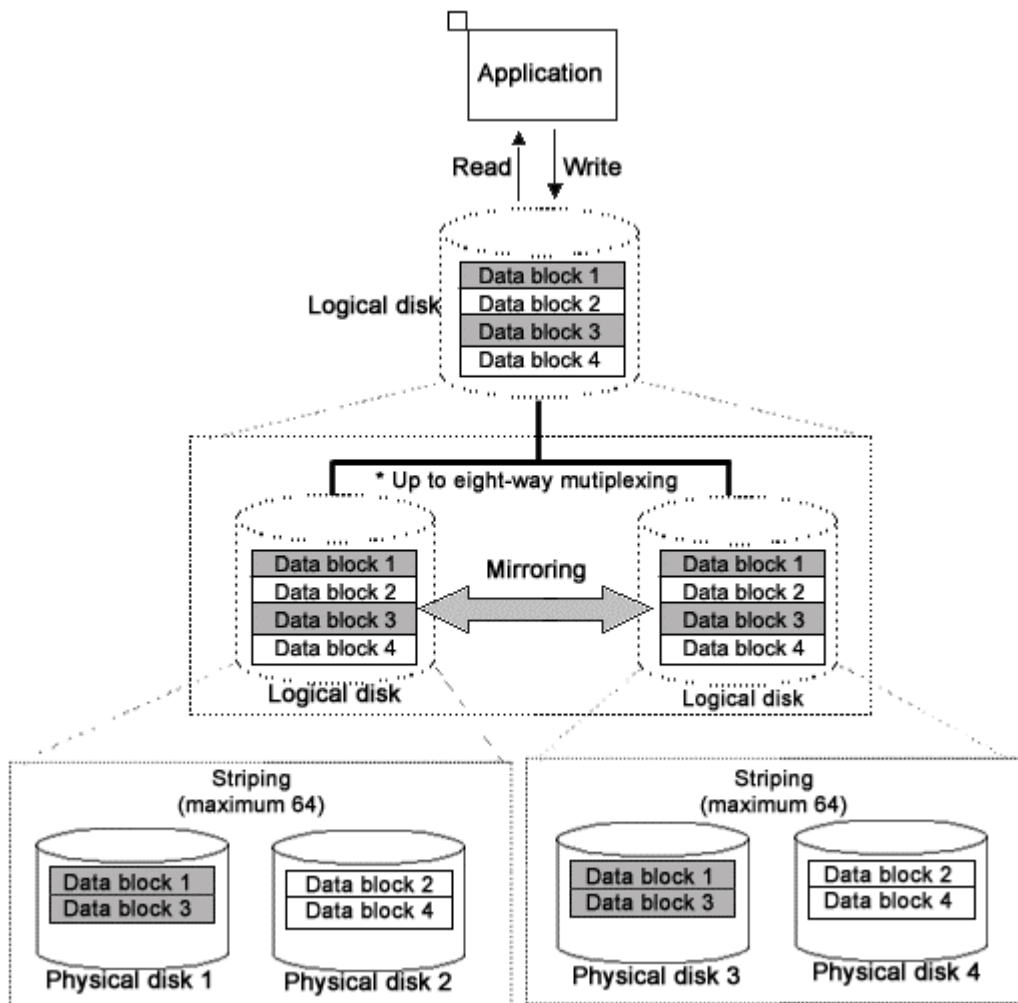

1.3.7 Online Volume Expansion

Overview

Volume expansion is a function that expands the capacity of volumes, retaining volume data. Volume expansion can be conducted without stopping applications using the volumes. This function is referred to as online volume expansion.

Volumes are expanded by disk area addition to areas after the last blocks of the volumes. Therefore, to expand a volume, there must be sufficient continuous free space following the last block of the volume.

Figure: Online Volume Expansion

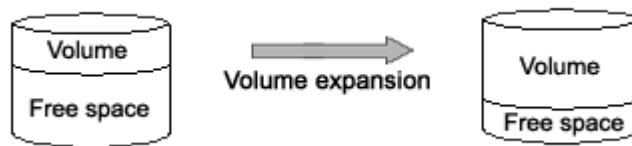

Concatenation and Online Volume Expansion

Even if there is no sufficient continuous free space after the last block of the volume, by concatenating unused disk, online volume expansion will be available.



Note Use Conditions on "Concatenation and Online Volume Expansion"

This function can expand only volumes that meet the following conditions.

- Concatenation and mirroring are both applied.
In other words, concatenated disks have been mirrored.
- The number of concatenated disks can be one.
- The multiplicity of mirroring can be one.

For details, see "Concatenation and Online Volume Expansion" in "A.2.11 Online Volume Expansion."

Figure: Concatenation and Online Volume Expansion

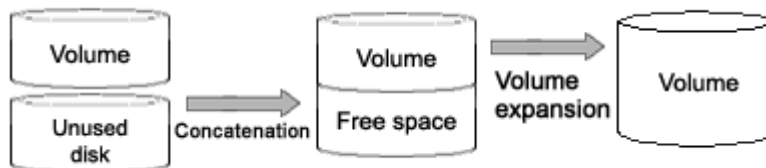

Online Disk Migration and Online Volume Expansion

Even if there is no sufficient continuous free space after the last block of the volume, by migration of the volume to a disk with sufficient free space, online volume expansion will be available. For the volume migration, use the GDS Snapshot online disk migration function.



See

For online disk migration, see "1.5.5 Online Disk Migration."

Figure: Online Disk Migration and Online Volume Expansion

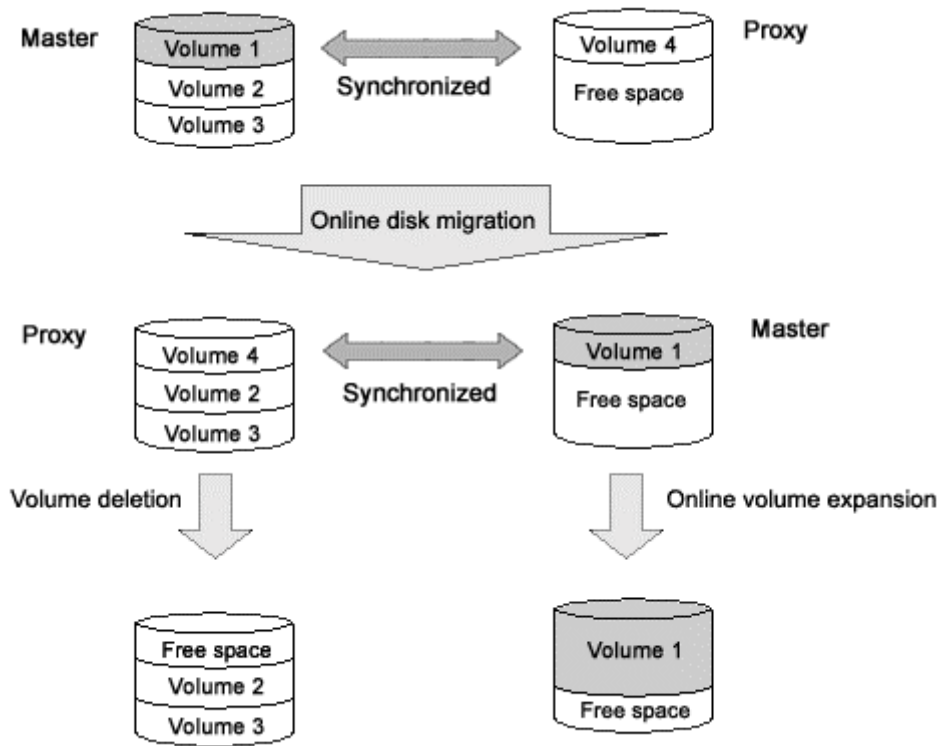

Operating Instructions

Use the `sdxvolume -S` command. For details, see "D.4 sdxvolume - Volume operations."



Note **Points of Concern for Online Volume Expansion**
See "A.2.11 Online Volume Expansion."

1.3.8 Snapshots by Slice Detachment

By temporarily detaching slices from mirror volumes, you can create snapshots (replications) of the volumes. In other words, by use of detached slices, volume data at the moment can be accessed.

Detached slices are logical devices separated from volumes, and other applications that use the detached slices can run simultaneously with service applications that use the volumes. For example, backup applications can be executed concurrently with service applications. By separating nodes running service applications that use the volumes from ones running applications that use detached slices, a management mode in which process loads are not imposed mutually can also be established.

After applications that use detached slices end, to create snapshots again, it is necessary to re-attach the detached slices to volumes. At this point, copying will be performed to synchronize data on the slices and the volumes. For this copying, GDS uses JRM (Just Resynchronization Mechanism) for slices to realize high-speed resynchronization by copying only the portions that were updated while slices were detached.

Figure: Snapshot by Slice detachment

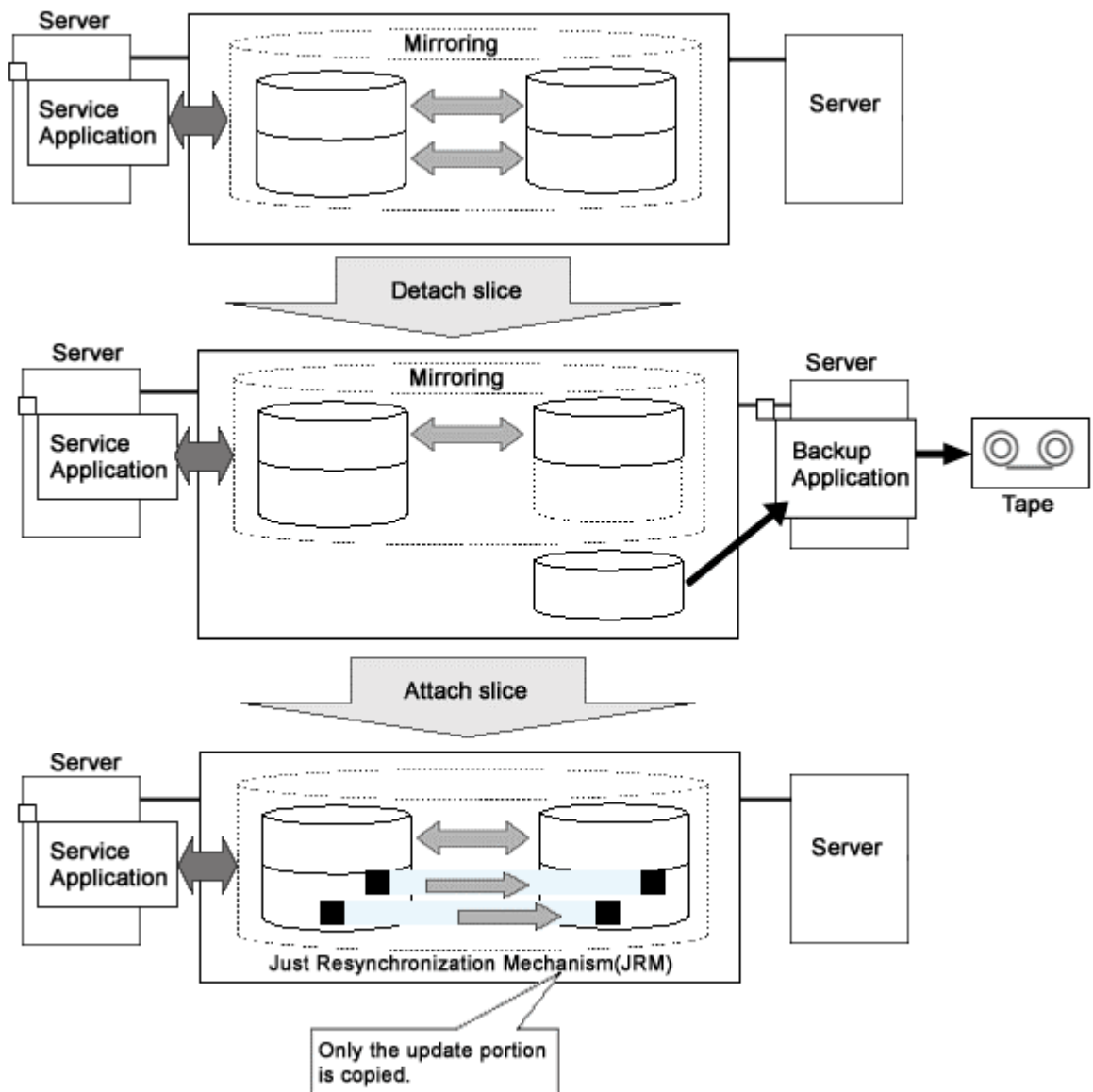



Note **Ensuring Integrity of Snapshot Data**

If you create a snapshot while an application is accessing the volume, the data integrity may not be ensured, as the volume data will be incomplete.

To ensure the integrity of your snapshot data, you must stop the application that is accessing the volume in advance.

After creating the snapshot, start the application again.

For example, when using the volume as a file system such as GFS or ext3, unmount the volume with the `umount (8)` command before creating a snapshot, and mount it with the `mount(8)` command afterwards. This way, you can ensure the integrity of the snapshot data.

To create a snapshot while running the application, the file system or database system you are using to manage the data must be able to ensure data integrity.



Note **JRM for Slices**

JRM for slices speeds up the resynchronization process when attaching a detached slice again to the volume. GDS records the changes made on the volume and slice in the memory while the slice is being detached. The resynchronization copy performed when the detached slice is reattached copies the updated portions only to realize high-speed resynchronization.

JRM for slices becomes effective when a slice is detached while the `jrm` attribute of the slices is on. However, if a system is stopped or if the slice is taken over by the `sdxslice -T` command while the slice is detached, just resynchronization is not conducted when the temporarily detached slice is attached again. Resynchronization is performed by copying the entire data, not only the updated portions.

Therefore, if you plan to shut down the system, or have a slice taken over, attaching the slice to the volume in advance is highly recommended.



Information **What is JRM?**

JRM stands for Just Resynchronization Mechanism, a feature that only allows duplication of the damaged part of data.



Information **Three Types of JRM**

There are three types of Just Resynchronization Mechanism (JRM): for volumes, for slices and for proxy. For details, see "A.2.10 Just Resynchronization Mechanism (JRM)."

1.4 GDS Snapshot Features

GDS Snapshot is software that provides additional functions to GDS.

GDS secures data from disk failures using the mirroring function and realizes continuous service. However, the mirroring function is not capable of protecting data against accidental erasure by the user or data crash due to an application malfunction. Therefore, data back up is mandatory. In a traditional system, the service must be stopped to back up data. GDS Snapshot provides a function for realizing the backup operation that does not influence the service and allows for continuous service.

The causes of cessation of services are not only problems such as disk failure and data damage. In a traditional system, the service must be stopped even for intentional maintenance work such as volume expansion and work applying patches to software. The function provided by GDS Snapshot also reduces system stop time and service stop time when performing maintenance work.

Once GDS Snapshot is implemented, proxy volumes and shadow volumes become available. These volumes are virtual devices that are bound up with GDS logical volumes. The user can make use of the GDS Snapshot function by operating and accessing those proxy volumes and shadow volumes.

The following sections discuss the GDS Snapshot functions provided by proxy volumes and shadow volumes.

1.5 Proxy Volume

A snapshot of the volume for the service application (a replication at a certain moment) can be created on another volume. The former is referred to as a master volume and the latter as a proxy (or an alternate) volume.

You can create a snapshot, or a copy of the master volume using the proxy volume.

Using this proxy volume will resolve to various issues.

For example, stopping a system with a large amount of data for backup purposes is becoming more and more difficult.

Conventionally, data was backed up overnight when no one was on the system. However, as the amount of data grows, backup often cannot be completed by the following morning.

Also, the widespread usage of Internet and service diversification has made it impossible to stop many systems.

Figure: Problems Inherent to a 24-hour Operation System

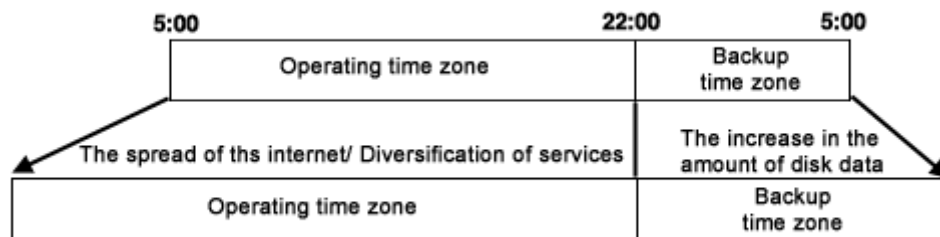

Since the proxy volume can be accessed separately while the service application is accessing the master volume, users can run a backup application in parallel without worrying about the time.

By using the proxy volume, users can conduct various tasks such as non-disruptive backup, data analysis, verification, and data protection from disaster, without affecting the main service application.

Figure: Backup Using the Proxy Volume

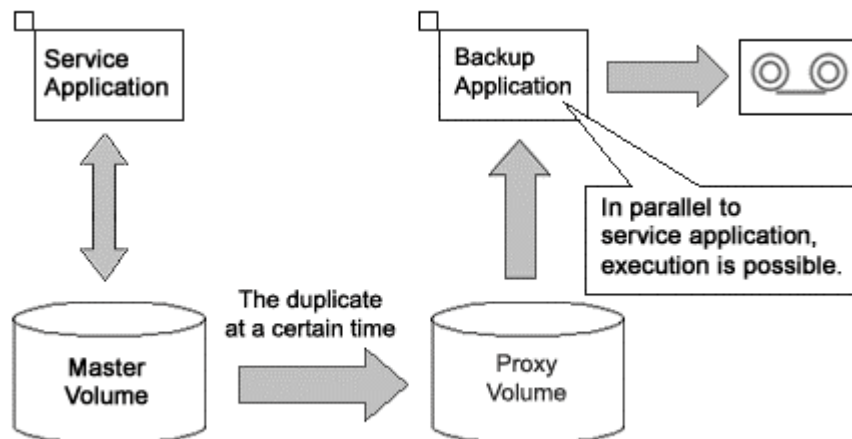

The user can utilize given logical volumes managed by GDS as master volumes or proxy volumes. It also provides snapshot operation that is consistent with GDS's various volume management function, such as access control function.

Figure: Liaising with Volume Management Function

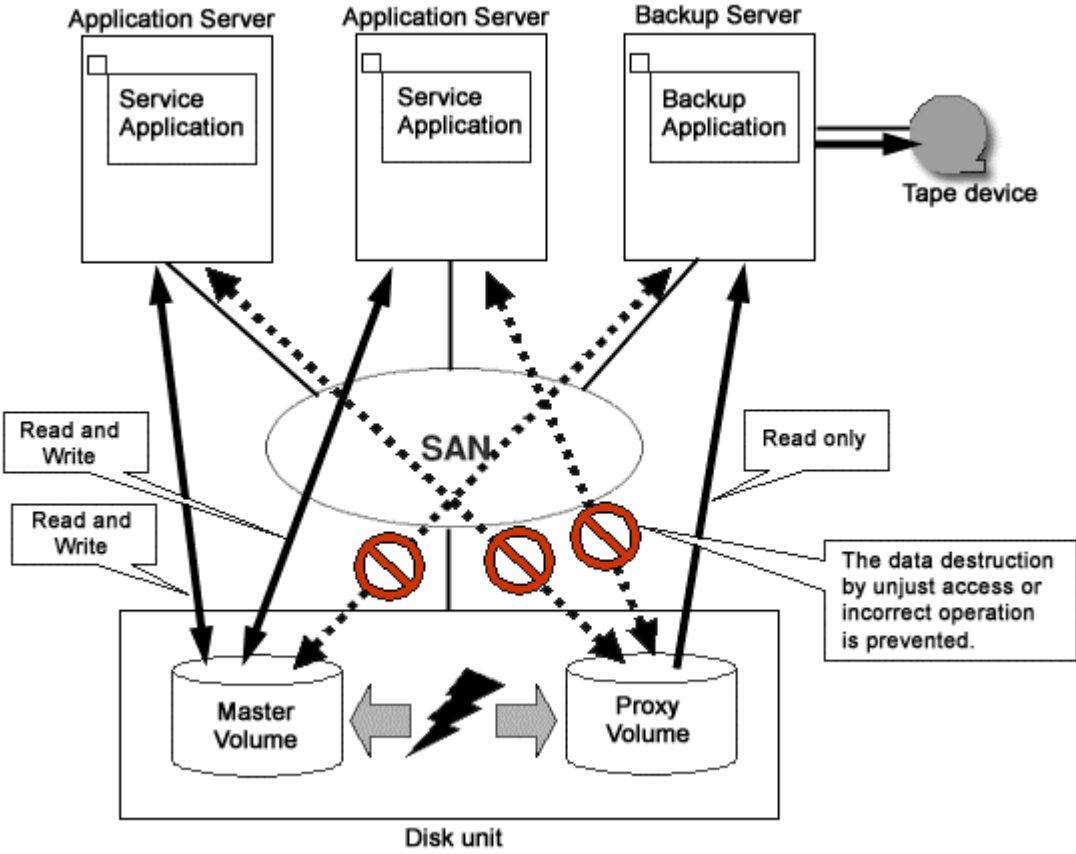

The snapshot functions using a proxy volume are explained here.

1.5.1 Snapshot by Synchronization

A master volume snapshot can be created by synchronizing data of the master volume and the proxy volume in advance and then separating the synchronized proxy volume from the master volume at any moment.

Snapshot by synchronization minimizes the influence on the service application and is suitable for routine scheduled backup.

As long as the two volumes are synchronized, snapshot can be created easily by separating the proxy volume from the master volume. Creation of snapshot will only take a few seconds even if the amount of data is large.

When the proxy volume is rejoined with the master volume for the next snapshot creation, high-speed resynchronization is performed by copying only updated portions on the master and proxy during the separation using JRM (Just Resynchronization Mechanism) for proxies.

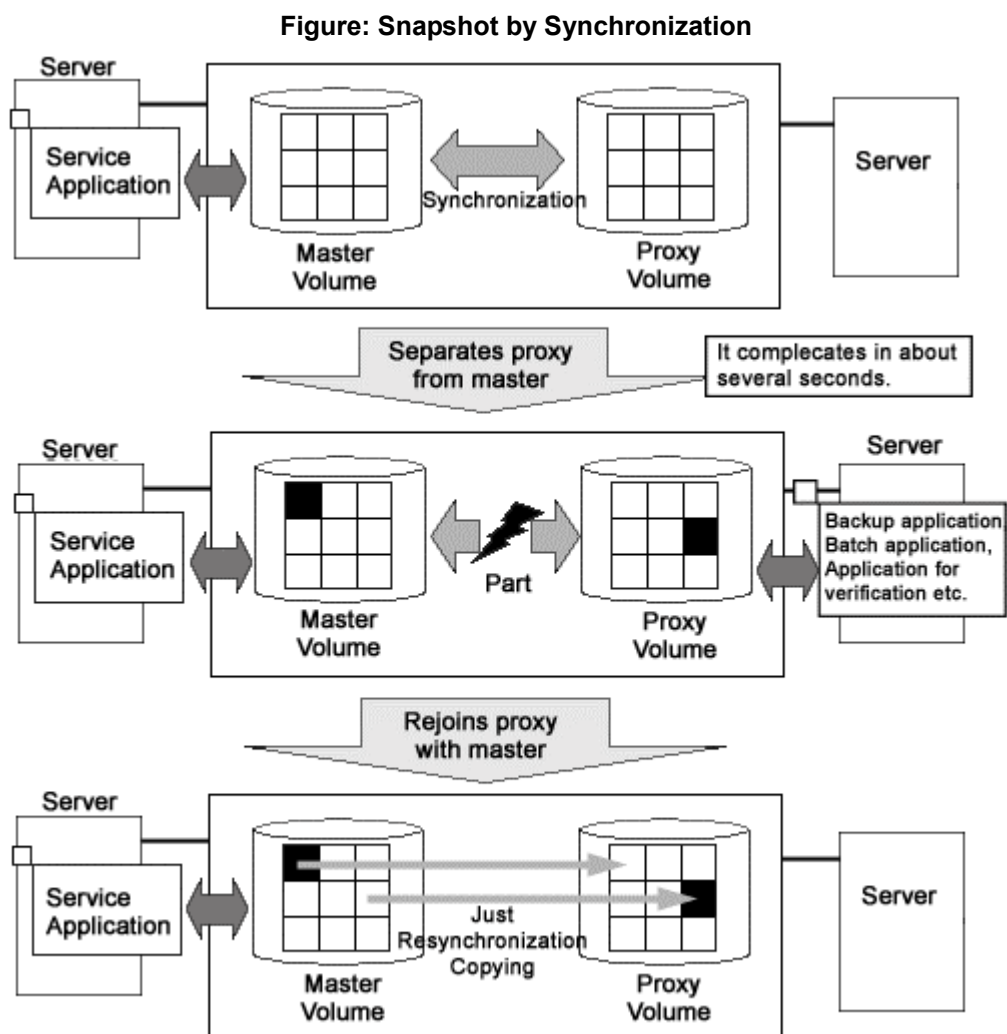

Therefore, both the snapshot creation and the resynchronization process before rejoining the proxy with master will have minimal influence on the service application.

For example, in a situation where loads imposed on disks are higher during the day than at night, if saving data to tape takes no more than 5 hours and resynchronization copying no more than an hour, the routine backup schedule is assumed as follows.

Figure: Example of a Daily Backup Schedule

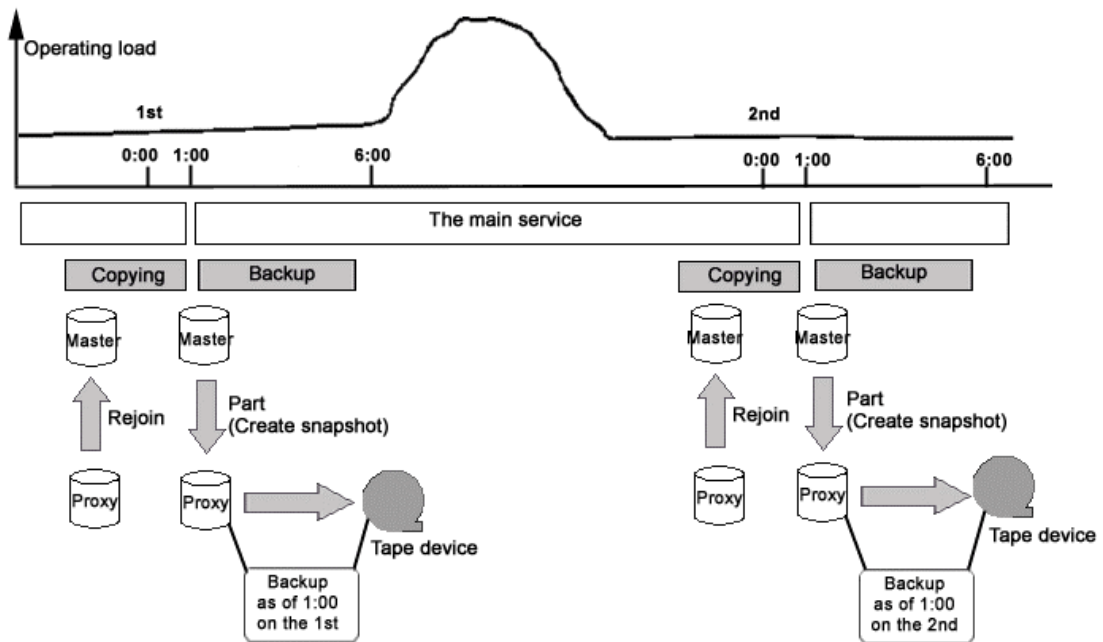

Note JRM for Proxies

JRM for proxies speeds up the just resynchronization process when joining a parted proxy again to the master and when the master data is restored from the proxy. GDS records the changes made on the master and the proxy on the memory while the proxy is parted. The just resynchronization conducted when re-joining or restoring copies only updates the updated portions to realize high-speed synchronization.

JRM for proxies is enabled when the `pjrm` attribute of a proxy volume is set to on and the proxy volume is parted. However, if any node that is included in the scope of the class is stopped while the proxy is parted, just resynchronization is not put in operation. In other words, the entire data, not only the updated portions, is copied.

Therefore, if you plan to shut down the system, joining the proxy to the master in advance is highly recommended.

Reference to these matters is not necessary when you are using the copy function of a disk unit.



Information Three Types of JRM

There are three types of Just Resynchronization Mechanism (JRM): for volumes, for slices and for proxy. For details, see "A.2.10 Just Resynchronization Mechanism (JRM)."



Note Ensuring integrity of snapshot data

If you create a snapshot while an application is accessing the volume, the data integrity may not be ensured, as the volume data will be incomplete.

To ensure the integrity of your snapshot data, you must stop the application that is accessing the volume in advance.

After creating the snapshot, start the application again.

For example, when using the volume as a file system such as GFS or ext3, unmount the volume with the `umount (8)` command before creating a snapshot, and mount it with the `mount(8)` command afterwards. This way, you can ensure the integrity of the snapshot data.

To create a snapshot while running the application, the file system or database system you are using to manage the data must be able to ensure data integrity.

For details, see "6.2 Online Backup and Instant Restore through Proxy Volume."



Note **The Difference between a Mirrored Slice and Synchronized Proxy Volume**

Although mirrored slices and synchronized master volume and proxy volume both have the same data, the ways they are used are different.

Mirrored slices are equals, and their purpose is to maintain data redundancy. So even if an abnormality is detected in one of the slices, the volume can be accessed as long as the other slice is normal.

However, even if the master volume and the proxy volume are synchronized, they are separate volumes and not equals. You may consider the master the primary volume, and the proxy the secondary volume. This means that even if the proxy volume is normal while all slices comprising the master volume are abnormal, you cannot continue accessing the master volume.

The purpose of proxy volumes is to separate the master volume in order to perform a different task in parallel, and not to improve the data redundancy used by the service application.

In short, the snapshot by slice detachment is a by-product of mirroring, which is the primary objective, but the primary objective of the snapshot through use of proxy volumes is creating snapshots. Therefore, GDS Snapshot provides more flexible disk configuration and supports various tasks.

Figure: Difference between a Mirrored Slice and Synchronized Proxy Volume

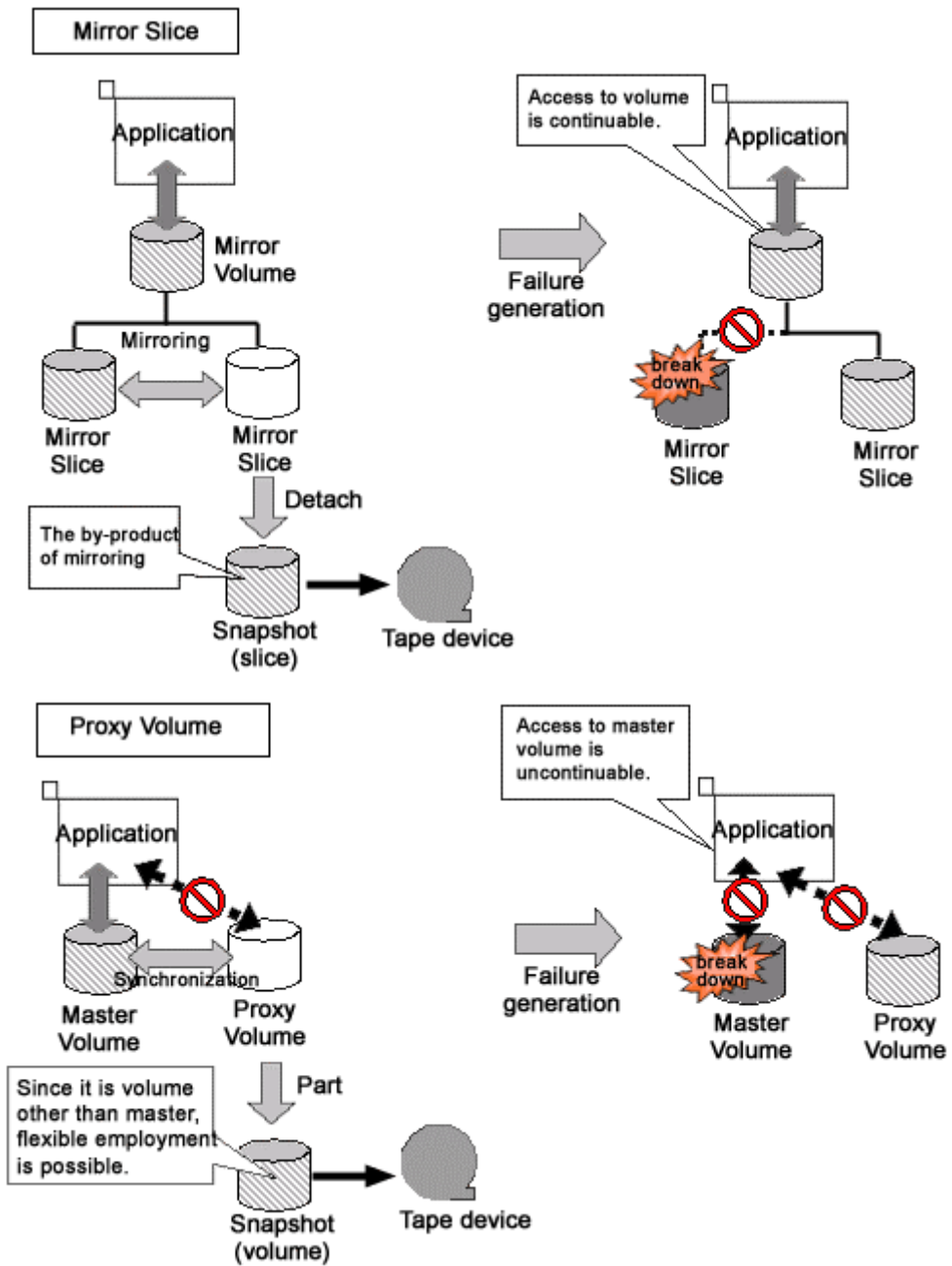

1.5.2 Snapshot Function with No Load to the server/SAN

By cooperation with the Advanced Copy function of a Fujitsu Storage Systems ETERNUS, processes such as copying for resynchronization, copying for maintaining synchronization, and recording the portion upgraded while proxies are being parted, are performed within the disk unit. Therefore, snapshots can be created without imposing loads on the server accessed by the service application, or the SAN (Storage Area Network).

As the operation is identical even when using GDS Snapshot with a disk unit lacking special copy function, there is no need for users to be aware of the differences between disk units.

Figure: Snapshot Function with No Load to the server/SAN

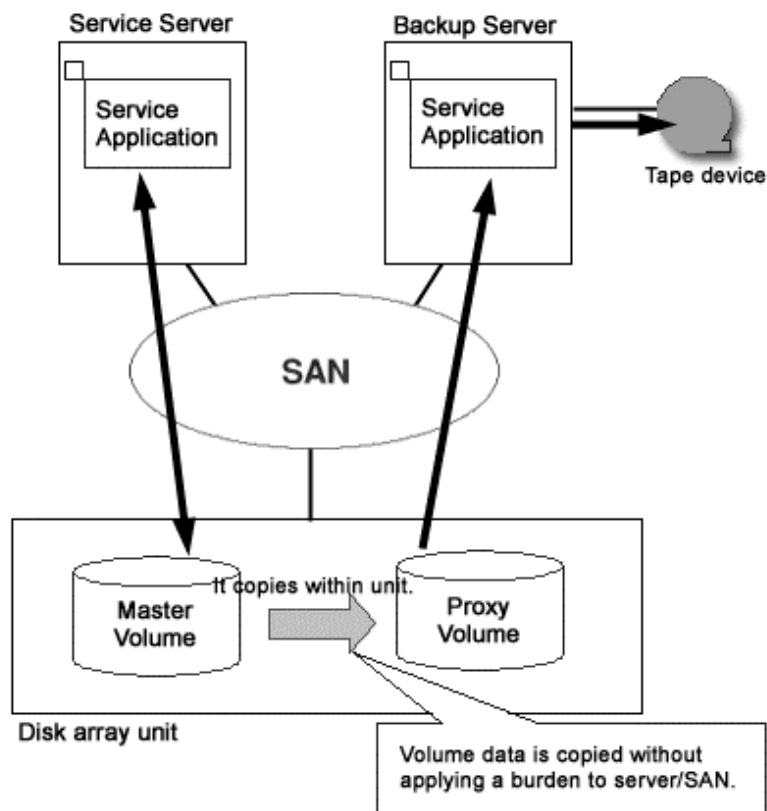

1.5.3 Instant Snapshot by OPC

By cooperation with the OPC (One Point Copy) function provided by a Fujitsu Storage Systems ETERNUS, snapshots can be created instantly at any given moment.

Unlike snapshot by synchronization, instant snapshot by OPC does not require synchronization with volumes in advance, so scheduling is unnecessary. However, as copying process will take place within the disk array after the snapshot has been created, I/O performance of the disk will be affected until the copying is complete.



Note Instant Snapshot by OPC

Instant snapshot by OPC is only available with the following storage systems supporting the function: ETERNUS6000, ETERNUS3000, GR720, GR730, and GR740.

Figure: Instant Snapshot by OPC

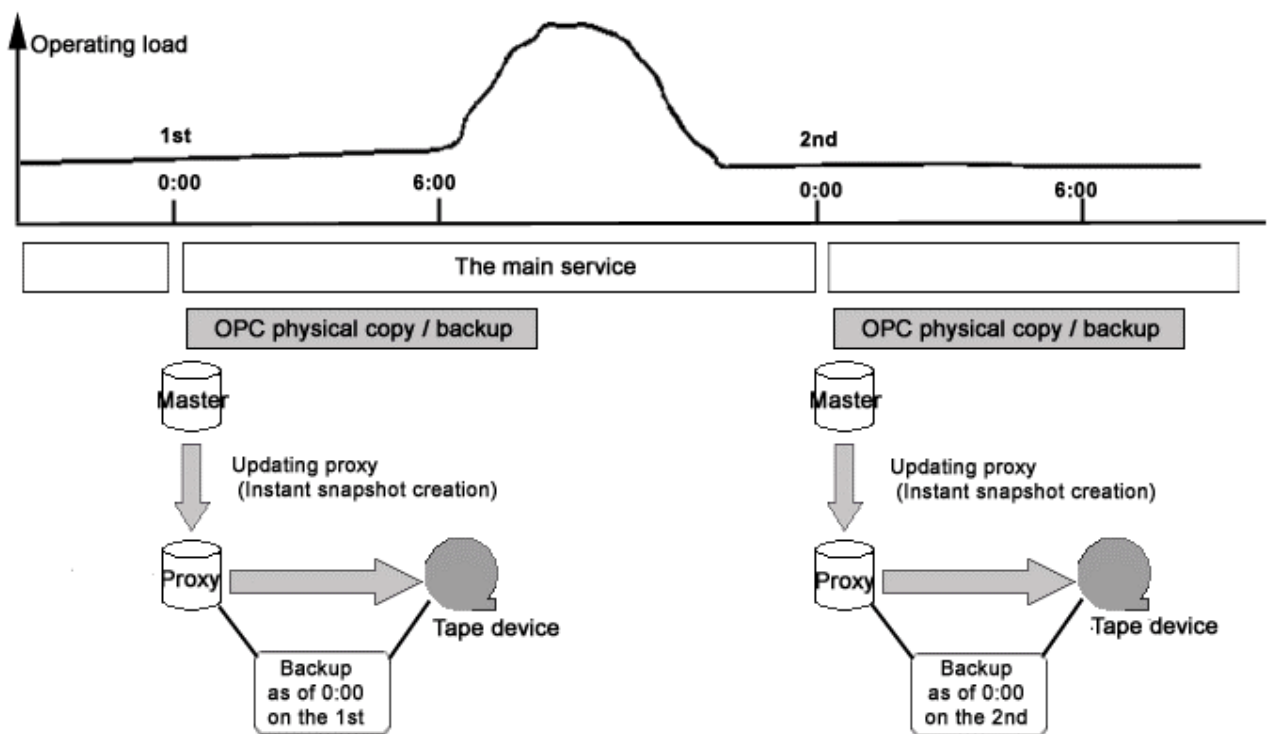

1.5.4 Instant Restore

For example, if a misoperation damages master volume data, you can still restore the master volume data using the proxy volume.

In this case, JRM (Just Resynchronization Mechanism) provides high-speed resynchronization by copying only portions that were updated while the master and proxy volumes were being separated. You can resume the service application immediately without waiting for the completion of the copying process. Synchronization copying process will take place in parallel with other tasks.

Users may use this function with any disk unit, as it is not dependent on a specific function of a disk unit.

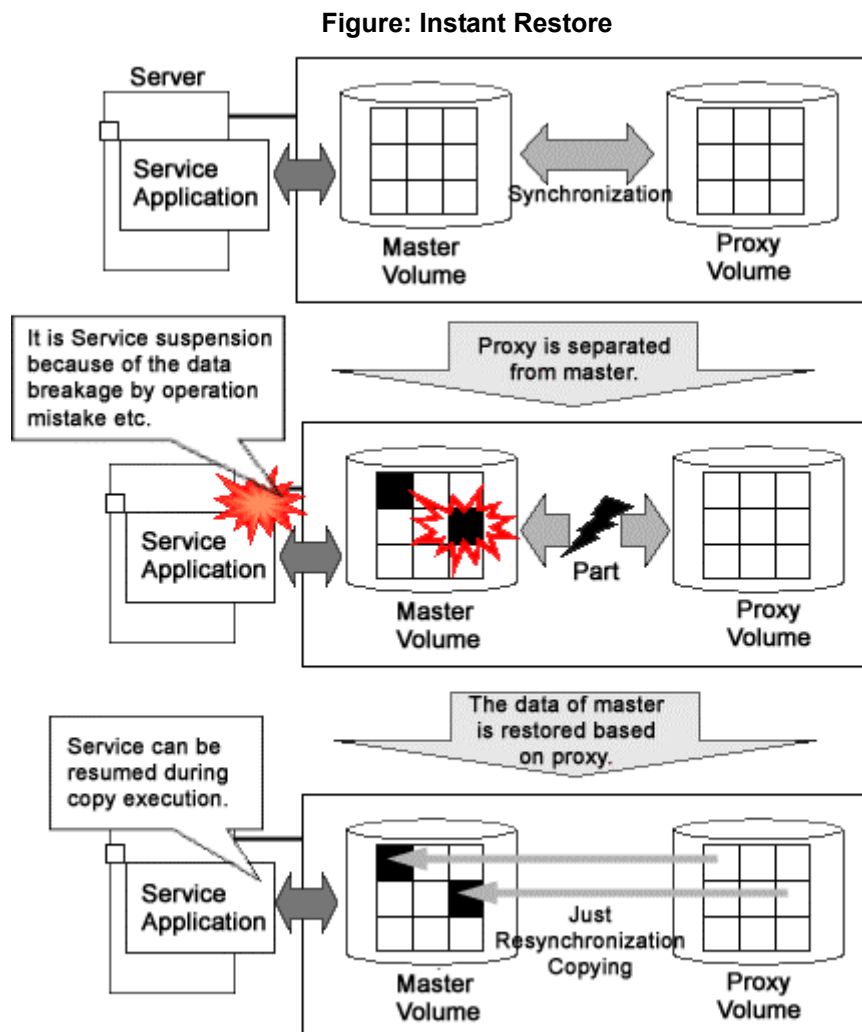

For example, in a situation where loads imposed on disks are higher during the day than at night, if saving data to tape takes no more than 5 hours and resynchronization copying no more than an hour, the routine backup schedule that enables instant restore from disks (proxy volumes) but not always from tape is assumed as follows.

Figure: Example of a Backup Schedule Allowing Instant Restore at All Times

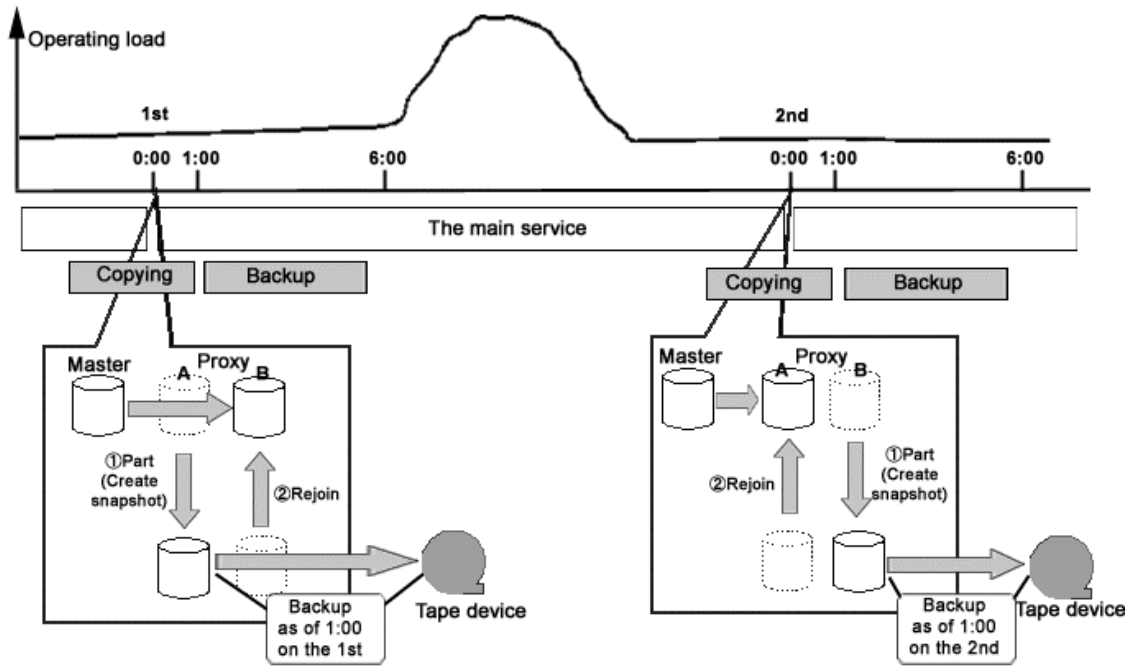

1.5.5 Online Disk Migration

When the master and proxy volumes are synchronized, migration from the physical disk used with the master volume to another is possible without affecting the service application.

This is done by exchanging the slice comprising the master volume with the slice comprising the proxy volume and is useful in situations such as upgrading your disk units.

Figure: Online Disk Migration

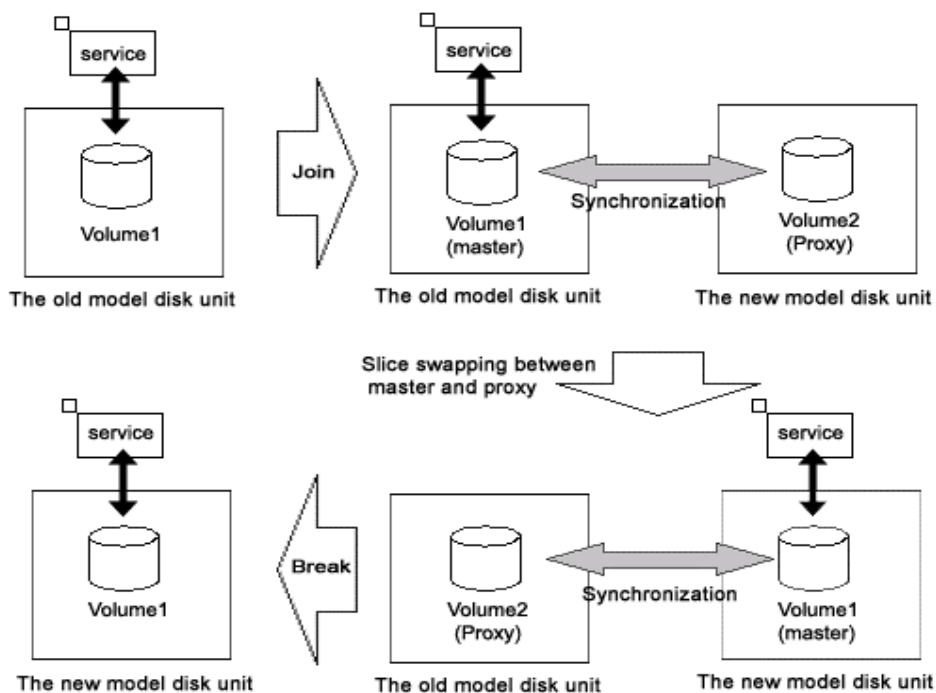

1.6 Shadow Volume

Volumes in other domains (cluster systems) connected to a SAN can be recognized as volumes (shadow volumes) and accessed.

This section describes the shadow volume feature.

1.6.1 Accessing Volumes from an External Server

In a SAN environment, disk areas used as volumes in other domains (cluster systems) can be recognized as volumes (shadow volumes) and accessed.

This feature allows a server that does not belong to the domain running the service to recognize and access volumes used in the service via the SAN. Not only the volumes used in the service but also the proxy volumes can also be recognized as shadow volumes by an external server. This capability enables another service, such as backup, restore, batch processing, and data analyses, to run concurrently with the service without imposing loads on the CPU, I/O, and the network of the domain running the service.

One server can recognize and access volumes in multiple domains connected to a SAN as shadow volumes. For example, you can configure a backup server that consolidates the backup and restoration of volumes in multiple domains.



See

For the operation patterns and the procedure for backup and restore by shadow volumes through an external server, see "6.3 Backing Up and Restoring through an External Server."

Figure: Backup Server

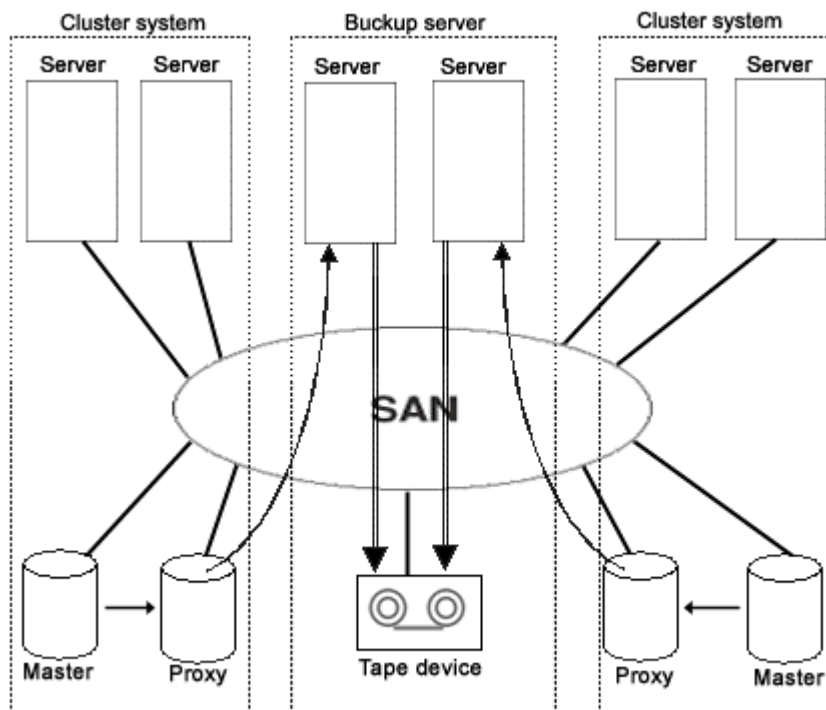

Chapter 2 Objects

GDS provides mirroring function and consistent manageability for disk units managed by GDS by virtualizing disk units as logical volumes. In this chapter, GDS object structure is explained so that you can understand the premise of logical volume management.

As GDS Snapshot, optional software of GDS, is implemented, proxy volumes and shadow volumes become available. By using proxy volumes and shadow volumes, the backup operation that can be conducted during service without affecting the running service can be realized.

This chapter systematically describes the virtual object structure that is the underlying basis of GDS and GDS Snapshot functionality to make it clear.

2.1 SDX Object

Virtual resources managed by GDS are called SDX objects, or objects.
There are five kinds of objects: classes, disks, groups, volumes and slices.

2.2 Disk Class

Disk class is the largest unit managed by GDS. Disk class may be referred to as "class".

In order to manage disk units (physical disks) with GDS, you must first register the physical disk with a certain class. A class is like a container that holds multiple disks for management.

By using the registered physical disks, GDS creates and manages objects such as disks, groups, volumes, and slices within a class.

Objects including classes can be named as the user wants. Respective names must be unique throughout the entire system.

Attributes

A class has the following attributes.

Name

This attribute identifies the class within a system.

Type

This attribute specifies the type of class. The type is set to the following value.

Shared

Object managed in a class that is available to more than one node.

Scope

This attribute indicates a group of nodes on which objects in the class are available.

Hot spare

This attribute indicates the hot spare operation mode. Either of the following values can be set.

on

Hot spare is enabled.

off

Hot spare is disabled. Automatic connections of spare disks are prevented.

Hot Spare Mode

This attribute indicates the spare disk selection mode of automatic connection for hot spare. One of the following values can be set.

External

If an I/O error occurs in a disk of a disk array unit, this method selects a spare disk that belongs to a different disk case from that of the failed disk. If an I/O error occurs in a disk irrelevant to a disk array unit, it selects a spare disk that is connected to a different controller from that of the failed disk. When no applicable unconnected spare disk is found there, a spare disk that belongs to the same disk case or is connected to the same controller as that of the disk with the I/O error, is selected.

Internal

If an I/O error occurs in a disk of a disk array unit, this method selects a spare disk that belongs to the same disk case as that of the failed disk. If an I/O error occurs in a disk irrelevant to a disk array unit, it selects a spare disk that is connected to the same controller as that of the failed disk. When no applicable unconnected spare disk is found there, spare disk automatic connection is not performed.

Operation

The following operations are available for classes.

Create

Registering a disk with the `sdxdisk -M` command and specifying a new class name will automatically create a new class. For details about GDS Management View, see "5.2.1.1 Class Configuration."

Delete

Deleting the last registered disk from a class using the `sdxdisk -R` command will automatically delete the class. You can also delete the classes with the `sdxclass -R` command. For details about GDS Management View, see "5.5.4 Removing a Class."

Status Display

Class status can be displayed with the `sdxinfo` command. For details about GDS Management View, see "5.3.1 Viewing Configurations and Monitoring Statuses."

Change Attributes

Class attribute values can be changed with the `sdxattr -C` command. For details about GDS Management View, see "5.4.1 Class Configuration."

Recover

Closed classes can be recovered with the `sdxfix -C` command. The operation from GDS Management View is unsupported.

Status

A class can have the following status.

Closed

All objects within a class are unavailable for reference. For details, see "F.1.4 Class status abnormality."

Reference

There are the following points of concern for classes.

Rules

- A.1.1 Object Name
- A.1.2 Number of Classes

Important Points

- A.2.1 Managing System Disks
- A.2.3 Booting from a CD-ROM Device
- A.2.18 Operation in Cluster System

Figure: Disk Class

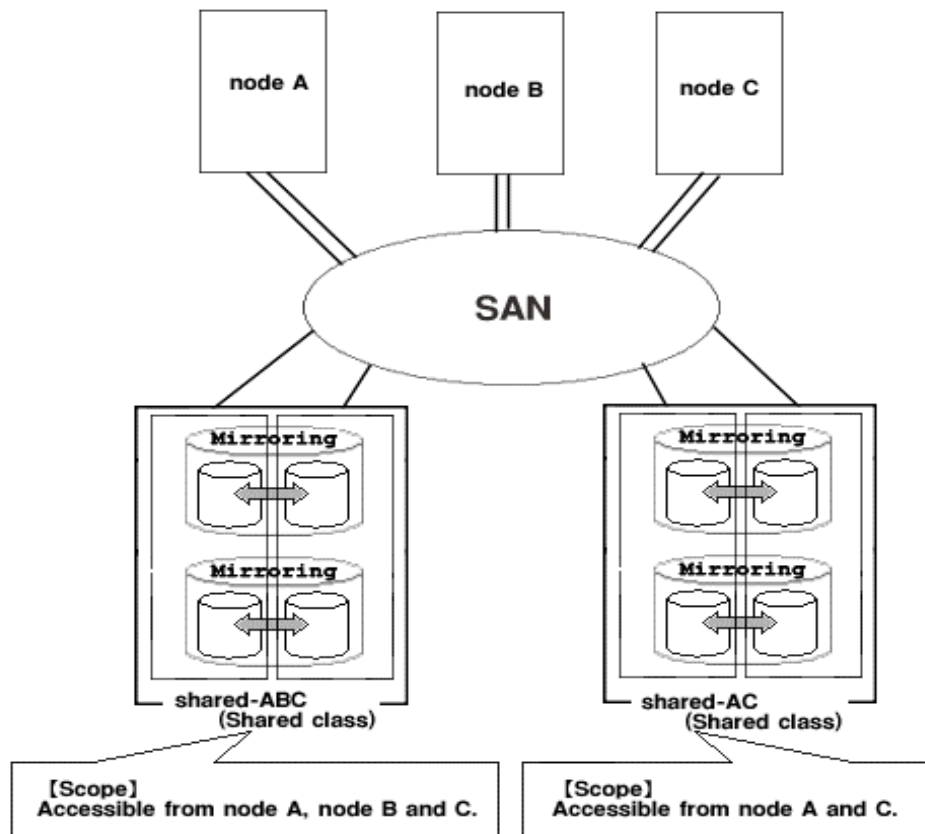

2.3 SDX Disk

Physical disks managed by GDS are registered with a certain class and are called SDX disks, or simply "disks." Disks that no longer need to be managed with GDS can be deleted from the class and are returned to their original physical disk status.

Attributes

A disk has the following attributes.

Name

This attribute identifies the disk within a class.

Type

This attribute indicates the type of disk. Either of the following values will be set.

Mirror

The disk has been connected to a mirror group.

Stripe

The disk has been connected to a stripe group.

Concatenation

The disk has been connected to a concatenation group.

Switch

The disk is connected to a switch group.

Single

A volume can be created without connecting to a group.

Spare

The disk will be used as a spare disk.

Undefined

The disk has been registered with the class without its usage being specified.

Operation

The following operations are available for disks.

Create

A disk can be created by registering a physical disk with a certain class, using the `sdxdisk -M` command. For details about GDS Management View, see "5.2.1.1 Class Configuration."

Delete

A disk can be deleted from a class with the `sdxdisk -R` command. For details about GDS Management View, see "5.5.4 Removing a Class."

Connect

A disk can be added to a certain group with the `sdxdisk -C` command. For details about GDS Management View, see "5.4.2 Group Configuration."

Disconnect

A disk can be disconnected from the group with the `sdxdisk -D` command. For details about GDS Management View, see "5.4.2 Group Configuration."

Swap

A disk can be prepared for swapping with the `sdxswap -O` command. For details about GDS Management View, see "5.3.4 Disk Swap."

Recover

Swapped disks can be recovered with the `sdxswap -I` command. For details about GDS Management View, see "5.3.4 Disk Swap."

Status Display

The disk status can be displayed with the `sdxinfo` command. For details about GDS Management View, see "5.3.1 Viewing Configurations and Monitoring Statuses."

Change Attributes

Disk attribute values can be changed with the `sdxattr -D` command. For details about GDS Management View, see "5.4.1 Class Configuration."

Clear Errors

The I/O error status of SDX disks can be cleared with the `sdxfix -D` command. The operation from GDS Management View is unsupported.

Status

A disk can have the following status.

ENABLE

The disk is in the normal status.

Unless you conduct a special operation, or a special event occurs, a disk is usually in the ENABLE status.

DISABLE

Data on the disk is inaccessible.

The configuration information of disks is checked on system startup, and if any disk is determined as a disk not managed with GDS, it is DISABLED. If this happens, all slices related to the disk are made the NOUSE status.

For details, see "F.1.2 Disk Status Abnormality."

SWAP

Data on the disk is inaccessible and the disk is ready for swapping.

Successful completion of the `sdxswap -O` command will make the disk the SWAP status. If this happens, all slices related to the disk are made the NOUSE status.

Reference

There are the following points of concern for disks.

Rules

A.1.3 Number of Disks

Important Points

A.2.2 Restraining Access to Physical Special File

A.2.4 Initializing Disk

A.2.5 Disk Size

A.2.7 Hot Spare

Figure: SDX Disk

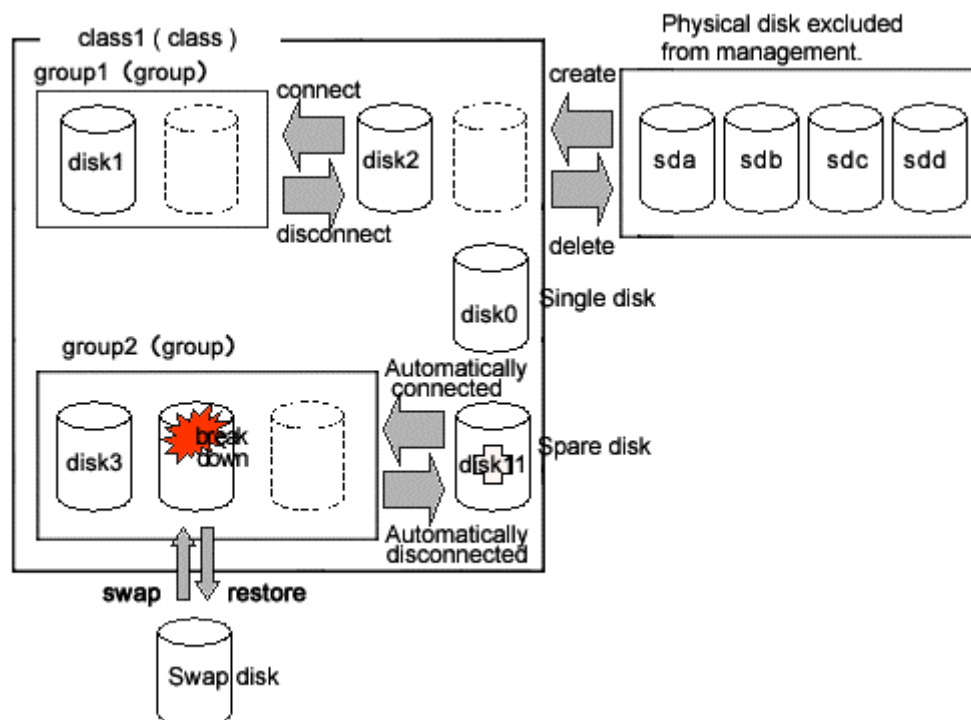

2.4 Disk Group

Disk group acts as container for disks that will be mirrored, striped, concatenated or switched. They may be simply referred to as "groups."

Among group attributes is a type attribute. Type attribute values may be "mirror", "stripe", "concat" or "switch". By connecting multiple disks to a group, the disks within that group can be mirrored, striped, concatenated or switched one another, depending on the group's type attribute value.

You can also create a hierarchy of groups by connecting a group to another group. A group belonging to another group is called a lower level group, and a group above that group is called a higher level group.

A group belonging to another group will retain its own function specified by type attribute, while also acting as a disk belonging to that group. For example, when more than one "stripe" type group is connected to a "mirror" type group, the connected "stripe" type groups will be mirrored to each other. So the disks belonging to the "stripe" type group will be striped and mirrored.

Attributes

A group has the following attribute.

Name

This attribute identifies the group within a class.

Type

This attribute specifies the type of group. You can set to one of the followings.

mirror

Disks and lower level groups belonging to the same group will be mirrored to each other. A maximum of 8 disks and lower level groups can be connected to a group collectively. In other words, a maximum of eight-way multiplex mirroring is supported.

stripe

Disks and lower level groups connected to the same group will each configure a stripe column, and will be striped. Since a maximum of 64 columns can be connected, you can stripe across a maximum of 64 columns.

concat

Disks connected to a concatenation group will be concatenated. Since a maximum of 64 disks can be connected, a maximum of 64 disks can be concatenated.

switch

The group consists of one active disk and one or less inactive disk. If an inactive disk is connected, the roles of the active and inactive disks can be switched.

Stripe Width

This is an attribute of "stripe" type group, which indicates the data unit size when data is striped.

Active Disk

This attribute indicates the active disk between disks that are connected to the switch type group.

Operation

The following operations are available for groups.

Create

Indicating a new (higher level) group when connecting a disk with the `sdxdisk -C` command, or connecting a group with `sdxgroup -C` command will automatically create a (higher level) group. For details about GDS Management View, see "5.2.1.2 Group Configuration."

Delete

Disconnecting the only remaining disk with the `sdxdisk -D` command, or disconnecting the only remaining lower level group with the `sdxgroup -D` command will automatically remove the (higher level) group. You can also delete a group using the `sdxgroup -R` command. For details about GDS Management View, see "5.5.3 Removing a Group."

Connect

You can add a group to another group with the `sdxgroup -C` command. A group that is connected to another group is called a lower level group, and a group to which the group is added is called a higher level group. For details about GDS Management View, see "5.4.2 Group Configuration."

Disconnect

The `sdxgroup -D` command disconnects the lower level group from the higher level group. For details about GDS Management View, see "5.4.2 Group Configuration."

Status Display

Group status can be displayed with the `sdxinfo` command.

For details about GDS Management View, see "5.3.1 Viewing Configurations and Monitoring Statuses."

Change Attributes

Group attribute values can be changed with the `sdxattr -G` command.

For details about GDS Management View, see "5.4.2 Group Configuration."

Reference

There are the following points of concern for groups.

Rules

A.1.4 Number of Groups

A.1.6 Creating Group Hierarchy

Important point

A.2.19 Disk Switch

Guide

A.3.1 Guidelines for Mirroring

A.3.2 Guidelines for Striping

A.3.3 Guidelines for Concatenation

A.3.4 Guidelines for Combining Striping with Mirroring

Figure: Disk Group

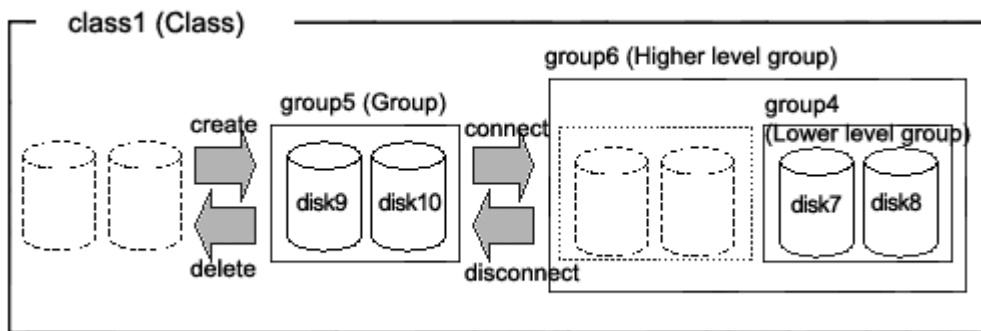

2.5 Logical Volume

GDS provides mirroring function and unified manageability by virtualizing physical disks as logical volumes.

An application will access the logical volume instead of the physical disk. Logical volumes are also called "volumes."

There are five kinds of volumes as follows:

- **Single Volume Created in a Single Disk**
Data will not be redundant.
Single volumes are used when it does not necessary to be mirrored, but needs to be managed by GDS. By connecting the single disk to a mirror group, a single volume can be changed to a mirror volume while retaining its data.
- **Mirror Volume Created in a Mirror Group**
When multiple disks and lower groups are connected to the mirror group, data will be redundant through the mirroring function.
- **Stripe Volume Created in a Stripe Group**
The striping function enables I/O load sharing across multiple disks.
Data will not be redundant.
- **Volume Created in a Concatenation Group**
Concatenation group allows users to create a large capacity volume spanning multiple disks. Its data will not be redundant.
- **Switch Volume Created in a Switch Group**
If an inactive disk is connected to a switch group in addition to the active disk, the active disk can be changed to the inactive disk with the disk switch function.

A volume created in the highest level group of a hierarchy will feature functions of its lower level groups as well. For example, a mirror volume created in a mirror group to which more than one stripe group are connected will feature both the I/O load distribution by the striping function and data redundancy by the mirroring function.

With an external disk (physical disk) in a Linux system, in general, a maximum of 16 partitions are only available. GDS allows users to create both a volume with a corresponding physical slice and a volume without a corresponding physical slice. So if you total the volumes with and without physical slices, single disks and groups can be partitioned to a maximum of 224 volumes and be used.

Attributes

A volume has the following attributes.

Name

This attribute identifies the volume within a class.

JRM

This attribute indicates the just resynchronization mechanism mode for volumes.

on

JRM for volumes is enabled.

off

JRM for volumes is disabled.

Lock Volume

This attribute sets the "Lock volume" mode. The value can be set to one of the followings.

on

The volume will be locked and prevented from activating.

off

The volume will not be locked.

Access Mode

This attribute sets the default access mode. If a volume is activated without specifying the access mode, the default setting will be applied. You can set to one of the followings.

rw

The default access mode is set to read and write.

ro

The default access mode is set to read only.

Physical Slice

This attribute indicates whether the volume has a physical slice or not. In other words, it indicates if the slice consisting the volume is registered with the partition table. The value can be set to one of the followings. However, note that physical slice attribute for volumes that are created in stripe group or concatenation group must be set to "off."

on

When the volume is a single volume, a slice in the single disk will be registered with the partition table. When the volume is a mirror volume, and if there are disks directly connected to the mirror group, the slices on the disks will be registered with the partition table. When the volume is a switch volume, slices on all of the disks connected to the switch group will be registered with partition table.

Mirror volumes created in mirror groups to which only lower level groups are connected have no physical slices even if this attribute is "on".

off

The volume has no physical slice. In other words, no slice in the volume is registered to the partition table.

PJRM

This attribute indicates the just resynchronization mechanism mode for proxies. Either of the following values can be set.

on

JRM for proxies is enabled.

off

JRM for proxies is disabled.

Operation

The following operations are available for volumes.

Create

A volume can be created in a single disk or the highest level group with the `sdxvolume -M` command.

For details about GDS Management View, see "5.2.1.3 Volume Configuration."

Delete

Volume will be deleted with the `sdxvolume -R` command.

For details about GDS Management View, see "5.5.2 Removing a Volume."

Start

Volume will be started with the `sdxvolume -N` command.

For details about GDS Management View, see "4.2.3 Operation."

Stop

Volume will be stopped with the `sdxvolume -F` command.

For details on GDS Management View, see "4.2.3 Operation."

Expand

The volume size can be expanded with the `sdxvolume -S` command.

The operation from GDS Management View is unsupported.

Status Display

Volume status can be displayed with the `sdxinfo` command.

For details about GDS Management View, see "5.3.1 Viewing Configurations and Monitoring Statuses."

Change Attributes

Volume attribute values can be changed with the `sdxattr -V` command.

For details about GDS Management View, see "5.4.3 Volume Configuration."

Copy control

Synchronization copying of volume can be controlled with the `sdxcopy` command.
For details about GDS Management View, see "5.3.6 Copying Operation."

Recover

Recovery attempt of an abnormal volume can be performed with the `sdxfix -V` command.
The operation from GDS Management View is unsupported.

Status

A volume can have the following status.

ACTIVE

Valid data is accessible.

After a volume is booted normally, it is given ACTIVE status. Here, there are one or more slices with ACTIVE or COPY (in the process of background copying) status within the volume.

STOP

Data is inaccessible, but the volume can be booted and made ACTIVE.

However, a proxy volume must first be parted from the master volume before activating. After the volume is stopped normally, it is given the STOP status.

Here, there are one or more slices with STOP or COPY (in process of background copying) status within the volume.

INVALID

Data is invalid and inaccessible.

Here, the volume cannot be activated since there are no valid slices (ACTIVE or STOP) or slices in the COPY status (in process of background copying) within the volume.

For details, see "F.1.3 Volume Status Abnormality."

Reference

There are the following points of concern for volumes.

Rules

A.1.5 Number of Volumes

Important Point

A.2.6 Volume Size

A.2.10 Just Resynchronization Mechanism (JRM)

A.2.17 Volume Access Mode

Figure: Logical Volume

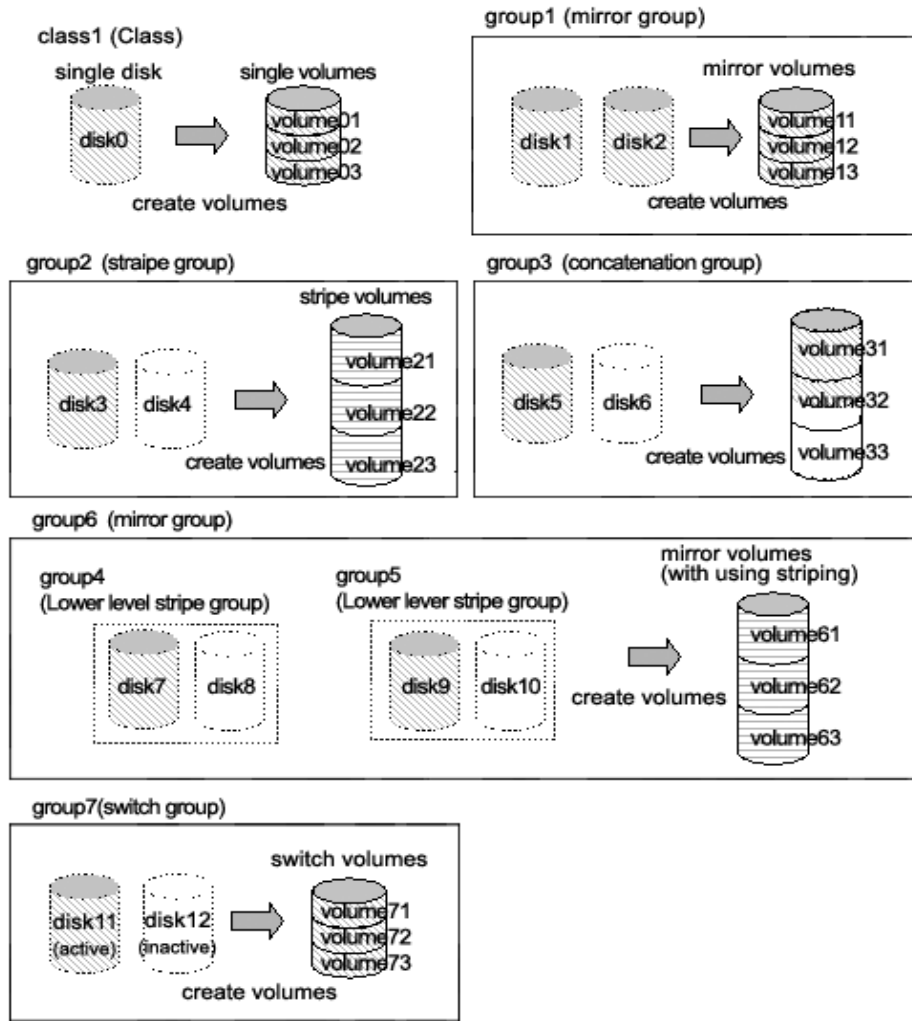
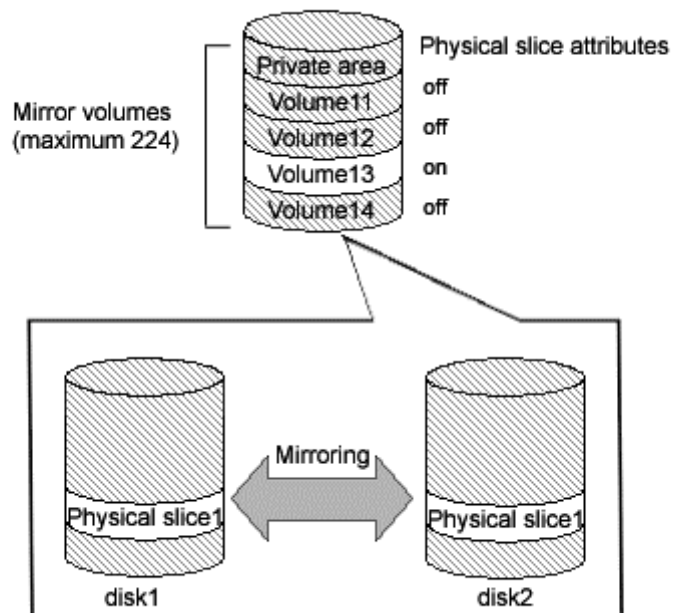

Figure: Logical Partitioning (Physical Slice Attribute)



2.6 Logical Slice

Logical slices are the smallest objects managed by GDS. A logical slice is also simply referred to as "slice."

Mirror volume is created by mirroring more than one logical slice. Each mirror volume will have one logical slice for every disk and lower level group belonging to the mirror group.

A single volume, stripe volume and a volume in concatenation group will each consist of one logical slice.

A switch volume consists of one logical slice, which is on the active disk.

Usually, an application cannot access the slices consisting a volume. But in the case of a mirror volume with its physical slice attribute set to "on," temporarily detaching the slice will allow the application to directly access the slice. A snapshot (replication) of the volume can be created with this function.

Attributes

A slice has the following attributes.

Name

This attribute identifies the slice within a class.

JRM

This attribute indicates the just resynchronization mechanism mode for slices.

on

JRM for slices is enabled.

off

JRM for slices is disabled.

Access Mode

This attribute sets the access mode. The value can be set to one of the followings.

rw

Sets access mode for read and write.

ro

Sets access mode for read only.

Operation

The following operations are available for slices.

Detach

A snapshot of a mirror volume can be created by detaching one of the slices consisting the mirror volume with the `sdxslice -M` command.

For details about GDS Management View, see "5.3.2.1 Backup (by Slice Detachment)."

Attach

The temporarily detached slice can be attached to the volume again with the `sdxslice -R` command.

For details about GDS Management View, see "5.3.2.1 Backup (by Slice Detachment)."

Activate

The detached slice can be activated with the `sdxslice -N` command.

For details about GDS Management View, see "5.3.2.1 Backup (by Slice Detachment)."

Stop

The detached slice can be stopped with the `sdxslice -F` command.

For details about GDS Management View, see "5.3.2.1 Backup (by Slice Detachment)."

Take over

Detached slice can be taken over from another node with the `sdxslice -T` command.

The operation from GDS Management View is unsupported.

Status Display

Slice status can be displayed with the `sdxinfo` command.

For details about GDS Management View, see "5.3.1 Viewing Configurations and Monitoring Statuses."

Change Attributes

Attribute values of the detached slice can be changed with the `sdxattr -S` command.

The operation from GDS Management View is unsupported.

Status

A slice can have the following status.

ACTIVE

Data is normal, and accessible.

Here, the volume is ACTIVE. The total number of slices that are in the ACTIVE, STOP, or COPY status (in process of background copying) within the mirror volume indicates the present multiplicity of the mirroring configuration (1 to 8).

STOP

Data is normal, but inaccessible.

Here, the volume is in the STOP status. The total number of slices that are in the STOP, ACTIVE, or COPY (in process of background copying) status within the mirror volume indicates the present multiplicity of the mirroring configuration (1 to 8).

INVALID

Data is invalid and inaccessible.

When an I/O error is detected in a slice during the mirroring process, the slice becomes INVALID.

Promptly identify the problem and restore the slice based on the disk driver message or the like.

After restoring the slice, execute the synchronization copying. When it ends successfully, the slice will be valid (the slice will be made the ACTIVE or STOP status). If it fails, it will be INVALID again.

COPY

Synchronization copying is in process to ensure the data integrity.

Synchronization copying is executed from a slice in the valid status (ACTIVE or STOP) to a slice in the COPY status.

When it ends successfully, the slice will be made valid (ACTIVE or STOP). If it fails, it will be INVALID.

TEMP

The slice is temporarily detached from the volume and can be accessed independently.

When the `sdxslice -M` command ends successfully, the slice is made the TEMP status.

To restore the status (ACTIVE or STOP), execute the `sdxslice -R` command.

TEMP-STOP

The slice is temporarily detached from the mirror volume, but cannot be accessed separately.

To make the slice accessible, activate the slice executing the `sdxslice -N` command or the `sdxslice -T` command.

NOUSE

The slice is inaccessible for a special reason.

When the disk is not available for operation (DISABLE or SWAP), all slices related to the disk are made the NOUSE status.

Reference

There are the following points of concern for slices.

Important Points

A.2.8 Creating a Snapshot by Slice Detachment

A.2.10 Just Resynchronization Mechanism (JRM)

Figure: Logical Slice

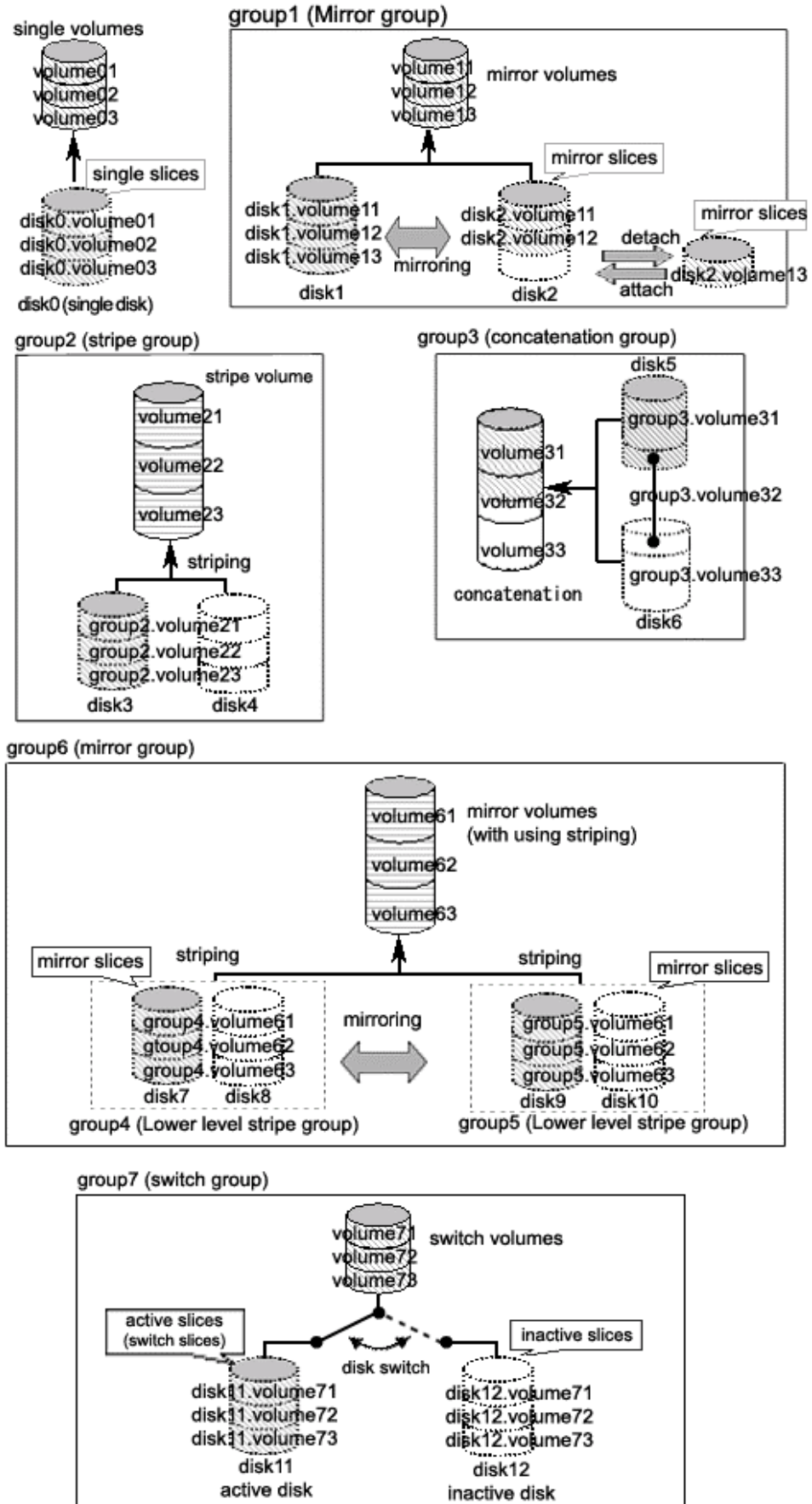

2.7 GDS Snapshot Objects

2.7.1 Proxy Object

An SDX object which is related to another SDX object (called master object) and plays the role of substitution of the master object is called a proxy object.

There are two kinds of proxy objects. The one is a proxy volume and the other is a proxy group.

A proxy volume can be joined and synchronized to a master volume, and they can be temporarily parted to become accessible as separate volumes. By joining and synchronizing the proxy volume to the master volume and then parting them, snapshot (copy at the moment) data of the master volume is instantly taken into the proxy volume.

A proxy group which is related to a master group has the same volume configuration as the master group. Each volume in the proxy group is a proxy volume of the corresponding master volume. By joining and synchronizing the proxy group to the master group and then parting them, snapshots of all the volumes in the master group are taken into the proxy group at a time.

Operation

The following operations are available for proxy objects.

Join

A pair of specified master and proxy volumes or master and proxy groups will be related and synchronized with the `sdxproxy Join` command.

For details about GDS Management View, see "5.2.3.1 Join."

Part

Master-proxy synchronization will be canceled and the proxy will be accessible as another device other than the master using the `sdxproxy Part` command. The master-proxy relationship will be maintained. The parted proxy will be a snapshot (a replication) of the master at that moment.

For details about GDS Management View, see "5.3.2.2 Backup (by Synchronization)."

Rejoin

The parted master and proxy will be resynchronized with the `sdxproxy Rejoin` command.

For details about GDS Management View, see "5.3.2.2 Backup (by Synchronization)."

Rejoin and Restore

The parted proxy is rejoined with the master, and master volume data will be restored using the proxy with the `sdxproxy RejoinRestore` command.

For details about GDS Management View, see "5.3.3 Restore."

Swap

The slices composing the master and those composing the proxy will be exchanged with the `sdxproxy Swap` command.

For details about GDS Management View, see "5.3.5 Disk Migration."

Relate

A pair of a master volume and a proxy volume or a master group and a proxy group can be related and parted, with the `sdxproxy Relate` command.

For details about GDS Management View, see "5.2.3.2 Relate."

Update

Data can be copied (overwritten) from a master to a parted proxy with the `sdxproxy Update` command. The updated proxy becomes a snapshot (a replica) of the master at the moment.

For details about GDS Management View, see "5.3.2.3 Backup (by OPC)."

Restore

Data from a parted proxy can be restored back to the master with the `sdxproxy Restore` command. The proxy data at the moment is copied (overwritten) to the master. For details about GDS Management View, see "5.3.3 Restore."

Cancel Copy Session

The session of a copy function of a disk unit residing between the master and the parted proxy can be canceled with the `sdxproxy Cancel` command. The operation from GDS Management View is unsupported.

Break

The specified relationship between a pair of volumes or groups as the master and proxy will be cancelled and they will return to individual objects with the `sdxproxy Break` command. For details about GDS Management View, see "5.5.5 Breaking a Proxy."

Status

The relationship between master volumes and proxy volumes will be one of the following statuses. These statuses can be viewed in the PROXY field for volumes displayed with the `sdxinfo` command.

Joined

Master and proxy are joined. In this status, the proxy cannot be accessed.

Parted

Proxy is parted from the master and can be accessed independently from the master (unless the volume is stopped explicitly)

Reference

There are the following points of concern for proxy objects.

Rules

- A.1.7 Exception to Proxy Configuration
- A.1.8 Number of Proxy Volumes
- A.1.9 Proxy Volume Size
- A.1.10 Proxy Group Size

Important Points

- A.2.9 The Difference between a Mirror Slice and a Proxy Volume
- A.2.10 Just Resynchronization Mechanism (JRM)
- A.2.12 Object Operation When Using Proxy
- A.2.13 Using the Advanced Copy Function in a Proxy Configuration
- A.2.14 Instant Snapshot by OPC
- A.2.15 Ensuring Integrity of Snapshot Data

Figure: Operating Proxy Objects

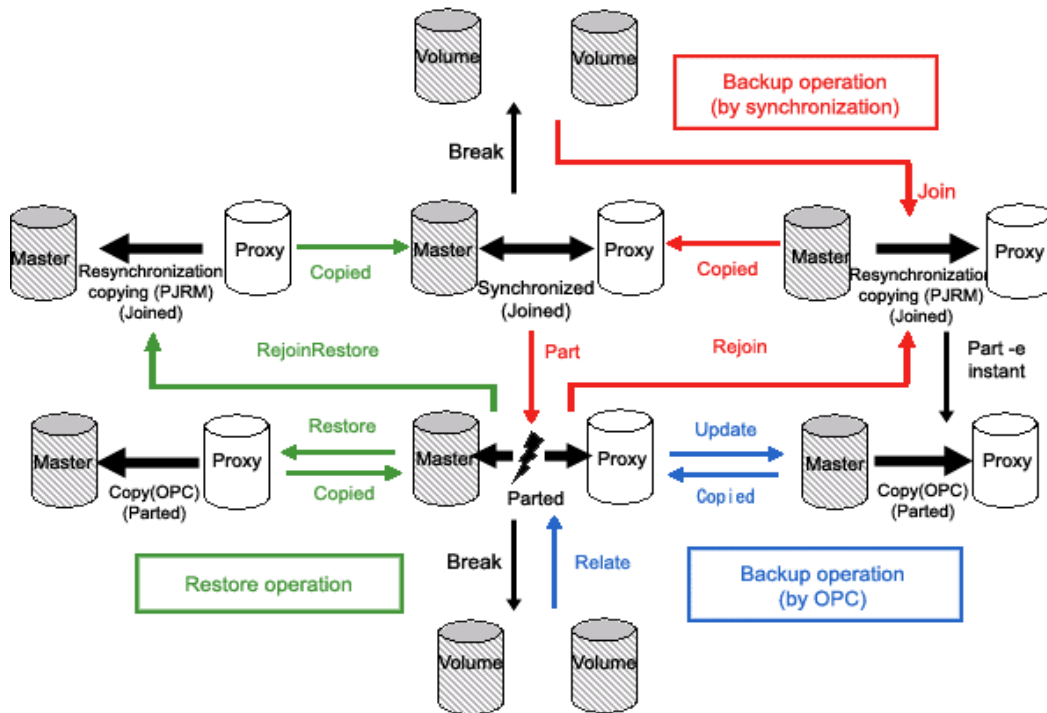

Figure: Swapping Master Volume and Proxy Volume

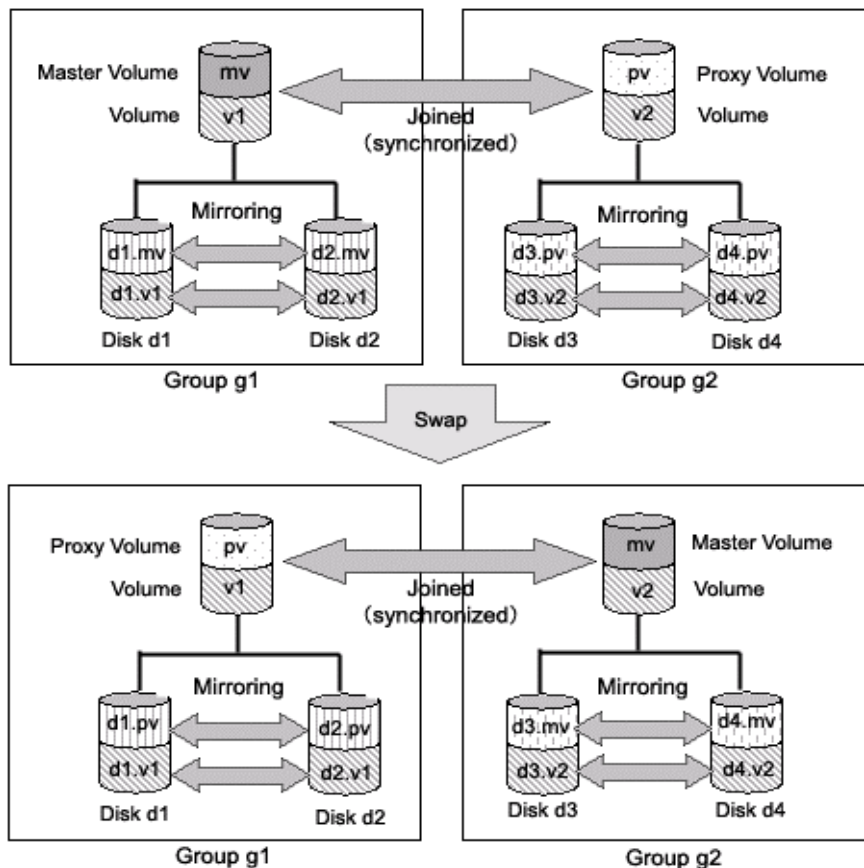
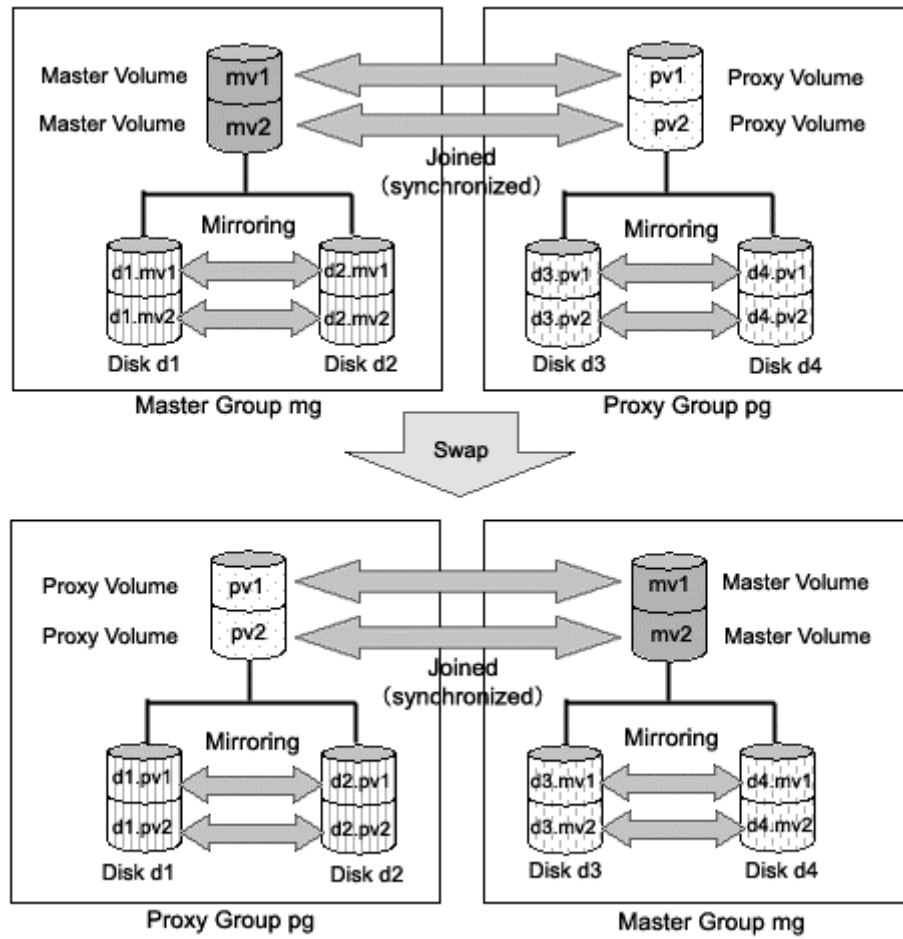

Figure: Swapping Master Group and Proxy Group



2.7.2 Shadow Object

There are five types of shadow object as follows: shadow classes, shadow disks, shadow groups, shadow volumes and shadow slices. These objects correspond to disk classes, SDX disks, disk groups, logical volumes and logical slices that are SDX objects respectively.

When SDX objects and shadow objects do not have to be classified particularly, they may be called "objects" collectively.

On the server where GDS Snapshot is installed, physical disks that are not registered with disk classes in the same domain and that store SDX disk management data, can be managed as shadow objects and accessed. Physical disks conforming to the following conditions can be managed as shadow objects.

- Disks registered with a class of GDS in another domain and managed as an SDX disk.

Shadow objects have the following characteristics.

- When shadow objects, such as shadow disks and shadow volumes, are configured or broken up, the physical disk format and data remain unchanged. For this reason, shadow volumes can be created without affecting data stored on the physical disks, and the data can be read in or write out through the shadow volumes.
- The configuration information of shadow objects is not saved on the private slices but managed on memory. Shadow objects are cleared by server reboot, but they can be reconfigured. However, if those objects in the same configuration are not created after the server reboot, restoration is necessary.
For details, see "Rebooting a Node" in "A.2.20 Shadow Volume."

Shadow objects other than shadow disks can be named as desired. The object names must be unique in the entire system. For details about the shadow disk naming restrictions, see "A.1.1 Object Name."

2.7.2.1 Shadow Class

A shadow class is the shadow object corresponding to a disk class that is an SDX object.

When disk classes and shadow classes do not have to be classified particularly, they may be called "classes" collectively.

Physical disks conforming to the following conditions can be registered with shadow classes.

- Disks registered with a class of GDS in another domain and managed as an SDX disk.
If this applies, with one shadow class, a physical disk registered with the class that has the same name in another domain can be registered. When multiple physical disks are registered with one class in another domain, part or all of those disks can be registered with a shadow class. It is also possible to register part of those disks to a shadow class and the other to another shadow class.

In addition, the sizes of the private slices of physical disks to be registered with the same shadow class must be the same.

Attributes

A shadow class has the following attributes.

Name

This attribute identifies the shadow class in a system.

Type

This attribute indicates the type of shadow class. The following value is set.

Local

The object managed in a shadow class is available only on the current node.

Scope

This attribute indicates a group of nodes on which objects in the shadow class are available. The current node name is set.

Operation

The operations other than status display are not available from Management View. Use the command for each operation.

Create

A new shadow class will be automatically created by specifying a new class name when registering a disk with the `sdxshadowdisk -M` command.

Delete

The shadow class will be automatically deleted by deleting the last registered shadow disk from a shadow class with the `sdxshadowdisk -R` command.

Status Display

The shadow class status can be displayed with the `sdxinfo` command. A shadow class is indicated by 1 (one) in the SHADOW field for class information displayed with the `sdxinfo -e` long command.

For details about GDS Management View, see "5.3.1 Viewing Configurations and Monitoring Statuses."

Status

Unlike a disk class, there is no possibility that a shadow class is closed down.

Reference

There are the following points of concern for shadow classes.

Rules

A.1.1 Object Name

A.1.2 Number of Classes

Important Points

A.2.18 Operation in Cluster System

The disks that are registered with a class in a certain domain (domain alpha in the figure below) and accordingly are managed as SDX disks can be registered with a shadow class in another domain (domain beta in the figure below) connected to the same SAN.

Figure: Example of Common Configuration with a Shadow Class

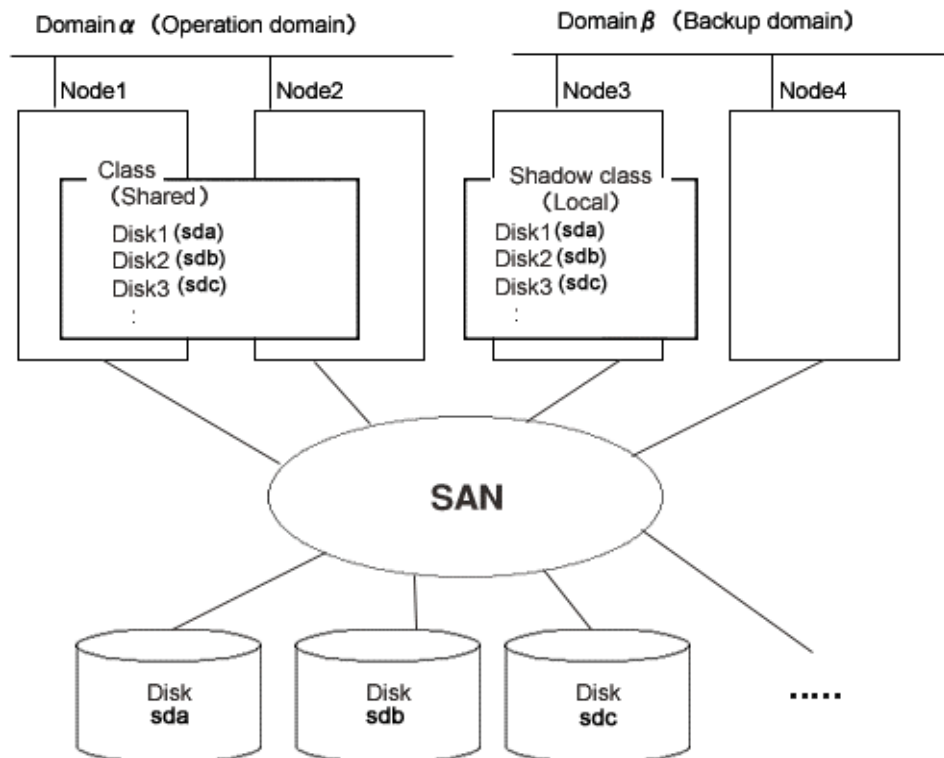

Note Physical Device Name

The same physical device name (such as sda) is not necessarily assigned to the identical physical device in domain alpha and domain beta.

2.7.2.2 Shadow Disk

A physical disk registered with a shadow class is called a shadow disk. A shadow disk is the shadow object corresponding to an SDX disk that is an SDX object.

When SDX disks and shadow disks do not have to be classified particularly, they may be called "disks" collectively.

Attributes

A shadow disk has the following attributes.

Name

This attribute identifies the shadow disk within a shadow class. There are the following restrictions.

- When it is registered with a class in another domain and managed as an SDX disk, the shadow disk must be named as same as the SDX disk in the said domain.

Type

This attribute indicates the type of shadow disk. Either of the following values will be set.

Mirror

The disk has been connected to a mirror group.

Stripe

The disk has been connected to a stripe group.

Concatenation

The disk has been connected to a concatenation group.

Single

A shadow volume can be created without connecting to a shadow group.

Undefined

The disk has been registered with the shadow class without its usage being specified.

Operation

The operation other than status display is not available from Management View. Use the command for each operation.

Create

A disk will be created by registering a physical disk with a certain shadow class using the `sdxshadowdisk -M` command.

Delete

The shadow disk can be deleted from a shadow class with the `sdxshadowdisk -R` command.

Connect

The shadow disk can be added to a certain shadow group with the `sdxshadowdisk -C` command.

Disconnect

The shadow disk will be disconnected from the shadow group with the `sdxshadowdisk -D` command.

Status Display

The shadow disk status can be displayed with the `sdxinfo` command. For details about GDS Management View, see "5.3.1 Viewing Configurations and Monitoring Statuses."

Status

A shadow disk can have the following status.

ENABLE

The shadow disk is in the normal status.

Reference

There are the following points of concern for shadow disks.

Rules

A.1.3 Number of Disks

Important Points

A.2.2 Restraining Access to Physical Special File

A.2.4 Initializing Disk

A.2.5 Disk Size

The physical disk that is registered with a class in a certain domain (domain alpha) with the `sdxdisk -M` command and accordingly is managed as an SDX disk can be registered with a shadow class in another domain (domain beta) with the `sdxshadowdisk -M` command and accordingly be managed as a shadow disk. The shadow disk must be named as same as the SDX disk.

Figure: An SDX Disk and a Shadow Disk

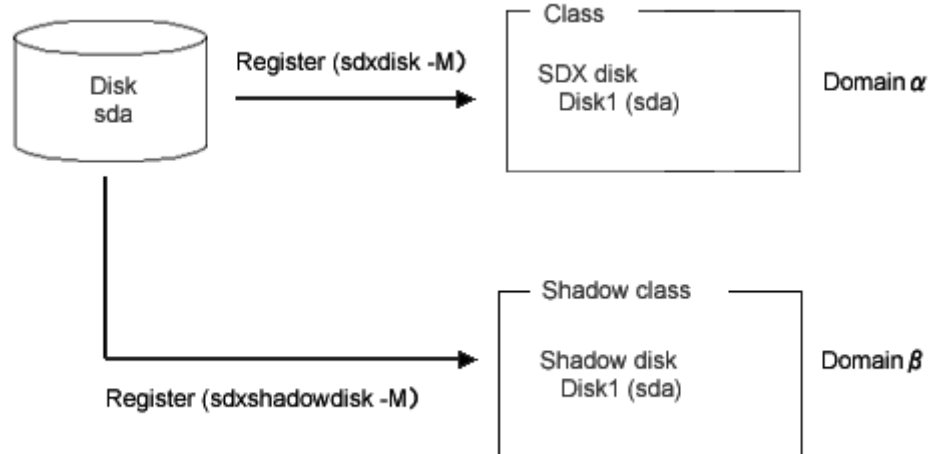

Note Physical Device Name

The same physical device name (such as `sda`) is not necessarily assigned to the identical physical device in domain alpha and domain beta.

2.7.2.3 Shadow Group

A shadow group is the shadow object corresponding to a disk group that is an SDX object.

When disk groups and shadow groups do not have to be classified particularly, they may be called "groups" collectively.

To access data on a logical volume through a shadow volume, a shadow group must be created in the same configuration as that of the disk group to which the logical volume belongs. The following configurations must be identical.

- Group type. This can be viewed in the TYPE field displayed with the `sdxinfo -G -e long` command.
- Disks constituting the group and disks constituting the lower level group. These can be viewed with the `sdxinfo -D` command and the `sdxinfo -G` command.
- Order of connecting disks and lower level groups when the group is the stripe type or the concatenation type. This can be viewed in the DISKS field displayed with the `sdxinfo -G` command.
- Stripe width when the group is the stripe type. This can be viewed in the WIDTH field displayed with the `sdxinfo -G -e long` command.

In addition, a shadow volume can be created by connecting only one of the following disks to a shadow group of the mirror type, and thus data on a single volume or on a slice temporarily detached can be accessed.

- Single disk.
- Disk containing a slice temporarily detached (in the TEMP status).

Attributes

A shadow group has the following attributes.

Name

This attribute identifies the shadow group within a shadow class.

Type

This attribute indicates the type of shadow group. One of the following values can be set.

mirror

Shadow disks and lower level shadow groups belonging to the shadow group will be mirrored to one another. A maximum of 8 disks and lower level shadow groups may be connected to a shadow group in total. In other words, a maximum of eight-way multiplex mirroring is supported.

stripe

Shadow disks and lower level shadow groups connected to the shadow group will configure stripe columns respectively and will be striped. Since a maximum of 64 shadow disks and lower level shadow groups can be connected to a shadow group in total, striping across a maximum of 64 columns is supported.

concat

Shadow disks connected to the shadow group are concatenated. Since a maximum of 64 shadow disks can be connected to a shadow group, a maximum of 64 shadow disks can be concatenated.

Stripe Width

This is an attribute of shadow groups of the "stripe" type, which indicates the data unit size when data is striped.

Operation

The operation other than status display from Management View is unsupported. Use the command for each operation.

Create

A shadow group (higher level) will automatically be created by specifying a new (higher level) shadow group name when connecting a shadow disk with the `sdxshadowdisk -C` command, or connecting a shadow group with the `sdxshadowgroup -C` command.

Delete

The shadow group (higher level) will be automatically removed by disconnecting the only remaining shadow disk with the `sdxshadowdisk -D` command, or by disconnecting the only remaining lower level shadow group with the `sdxshadowgroup -D` command. You can also delete a shadow group with the `sdxshadowgroup -R` command.

Connect

A shadow group will be added to another shadow group with the `sdxshadowgroup -C` command. A shadow group that is connected to another shadow group is particularly called a lower level shadow group, and a shadow group to which another shadow group is connected is particularly called a higher level shadow group.

Disconnect

The lower level shadow group will be disconnected from the higher level shadow group with the `sdxshadowgroup -D` command.

Status Display

The shadow group status can be displayed with the `sdxinfo` command. For details about GDS Management View, see "5.3.1 Viewing Configurations and Monitoring Statuses."

Reference

There are the following points of concern for shadow groups.

Rules

A.1.4 Number of Groups

A.1.6 Creating Group Hierarchy

2.7.2.4 Shadow Volume

A volume created in a shadow group or a shadow disk of the single type is called a shadow volume. The users and applications will access data on the shadow volumes instead of the physical disks. A shadow volume is the shadow object corresponding to a logical volume that is an SDX object.

When logical volumes and shadow volumes do not have to be classified particularly, they may be called "volumes" collectively.

Create shadow volumes conforming to the following rules in order to use the shadow volumes to access data in the corresponding logical volumes.

- Equal to the corresponding logical volumes in size. For volume sizes, check the BLOCKS field displayed with the `sdxinfo -V` command.
- Whose the first block numbers must be consistent with the first block numbers of the corresponding logical volumes. Therefore, create shadow volumes within the same shadow group or shadow disk in ascending order in conformity to the order of the first block numbers of the corresponding logical volumes. For the first block numbers of volumes, check the 1STBLK field displayed with the `sdxinfo -V` command.

Synchronization copying is not conducted when a shadow volume of the mirror type is created. When a shadow volume corresponding to a mirror volume is to be created, synchronization of the mirror volume must be ensured in advance by the use of GDS managing that mirror volume.

Shadow volumes and the corresponding logical volumes are managed independently. For example, the change on the slice status in one volume is not updated on the slice status in the other volume. For this reason, you must note certain operational particulars when using shadow volumes. For details, see "A.2.20 Shadow Volume."

Attributes

A shadow volume has the following attributes.

Name

This attribute identifies the shadow volume within a shadow class.

JRM

This attribute identifies the just resynchronization mechanism mode. The following value is set.

off

JRM is inactive.

Lock Volume

This attribute identifies the "Lock volume" mode. The following value is set.

off

The volume will not be locked.

Access Mode

This attribute sets the default access mode. If a volume is activated without specifying the access mode, the default setting will be applied. The following value is set.

ro

The default is set to read only.

The access mode attribute value cannot be set to `rw` (read and write). To write data on a shadow volume, the shadow volume must first be stopped and reactivated in the read and write mode using the `sdxshadowvolume -N` command with the `-e mode=rw` option.

Physical Slice

This attribute is always set to `off` regardless whether the shadow volume has a physical slice, which means the shadow slice is registered with partition table.

Operation

The operation other than status display from Management View is unsupported. Use the command for each operation.

Create

A shadow volume can be created in the highest level shadow group or a shadow disk of the single type with the `sdxshadowvolume -M` command.

Delete

The shadow volume can be deleted with the `sdxshadowvolume -R` command.

Start

The shadow volume can be started with the `sdxshadowvolume -N` command.

Stop

The shadow volume can be stopped with the `sdxshadowvolume -F` command.

Status Display

The volume status can be displayed with the `sdxinfo` command.

For details about GDS Management View, see "5.3.1 Viewing Configurations and Monitoring Statuses."

Status

A shadow volume can have the following status.

ACTIVE

Data is accessible.

After a shadow volume is started normally, it is given ACTIVE status. Here, there are one or more shadow slices in the ACTIVE status in the shadow volume.

STOP

Data is inaccessible, but the shadow volume can be activated and be ACTIVE.

After the shadow volume is stopped normally, it is given STOP status. Here, there are one or more shadow slices in STOP status in the shadow volume.

Reference

There are the following points of concern for shadow volumes.

Rules

A.1.5 Number of Volumes

Important Point

A.2.6 Volume Size

A.2.17 Volume Access Mode

A.2.20 Shadow Volume

Multiple physical disks virtualized as a logical volume in a certain domain (domain alpha in the figure below) can be virtualized as a shadow volume in another domain (domain beta in the figure below), and the shadow volume can be used in order to access the data on the logical volume in domain alpha from domain beta. The primary service (service A in the figure below) can be run by the use of the logical volume in domain alpha, and another service (service B: for example, backup and restore, restore, batch processing) can be run by the use of the shadow volume in domain beta. However, service A and service B cannot be run simultaneously. If they are run simultaneously, data consistency between disks is not ensured.

Figure: A Logical Volume and a Shadow Volume

* Service A and service B cannot be run simultaneously

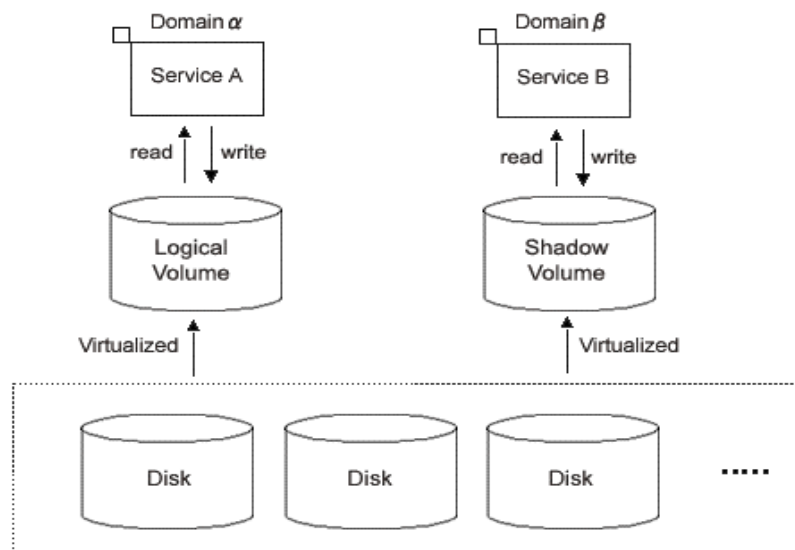

One physical disk temporarily detached from mirroring among multiple physical disks virtualized as a mirror volume in a certain domain (domain alpha in the figure below) can be virtualized as a shadow volume in another domain (domain beta in the figure below), and the shadow volume can be used in order to access the data on the temporarily detached slice in domain alpha from domain beta. The primary service (service A in the figure below) can be run by the use of the mirror volume in domain alpha from which one slice is temporarily detached, and another service (service C: for example, backup and restore, restore, batch processing) can be run by the use of the shadow volume in domain beta simultaneously. However, when a different service (service B in the figure below) is run by the use of the temporarily detached slice in domain alpha, service B and service C cannot be run simultaneously. If they are run simultaneously, data consistency between disks is not ensured.

Figure: Mirror Slice Temporary Detachment and a Shadow Volume

* Service B and service C cannot be run simultaneously

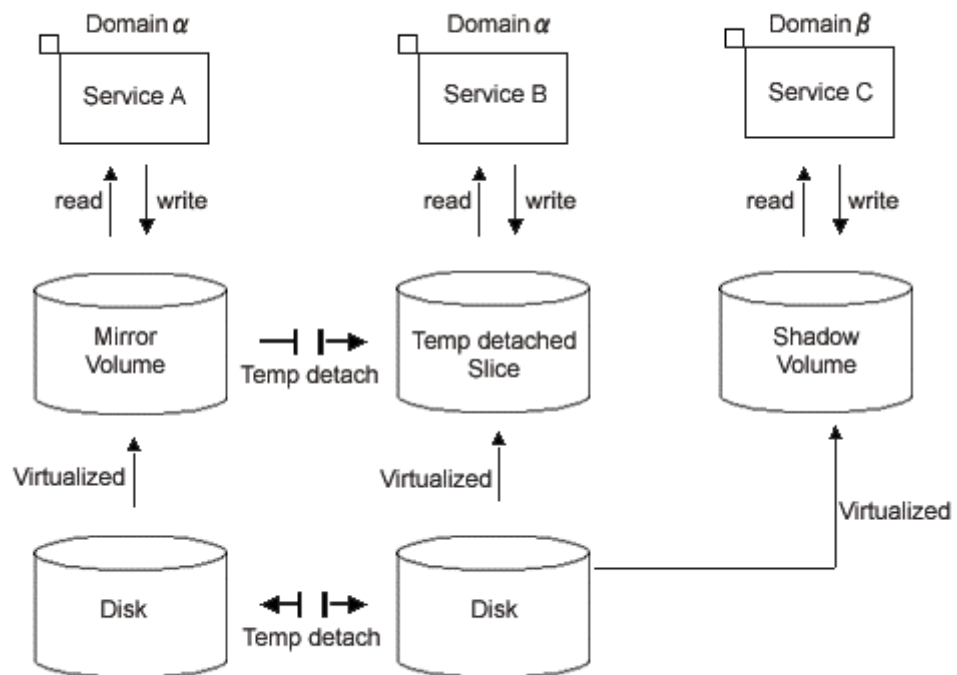

Multiple physical disks virtualized as a proxy volume in a certain domain (domain alpha in the figure below) can be virtualized as a shadow volume in another domain (domain beta in the figure below), and the shadow volume can be used in order to access the data on the proxy volume in domain alpha from domain beta. The primary service (service A in the figure below) can be run by the use of the master volume in domain alpha from which the proxy is parted, and another service (service C: for example, backup and restore, restore, batch processing) can be run by the use of the shadow volume in domain beta simultaneously. However, when a different service (service B in the figure below) is run by the use of the proxy volume in domain alpha, service B and service C cannot be run simultaneously. If they are run simultaneously, data consistency between disks is not ensured.

Figure: A Proxy Volume and a Shadow Volume

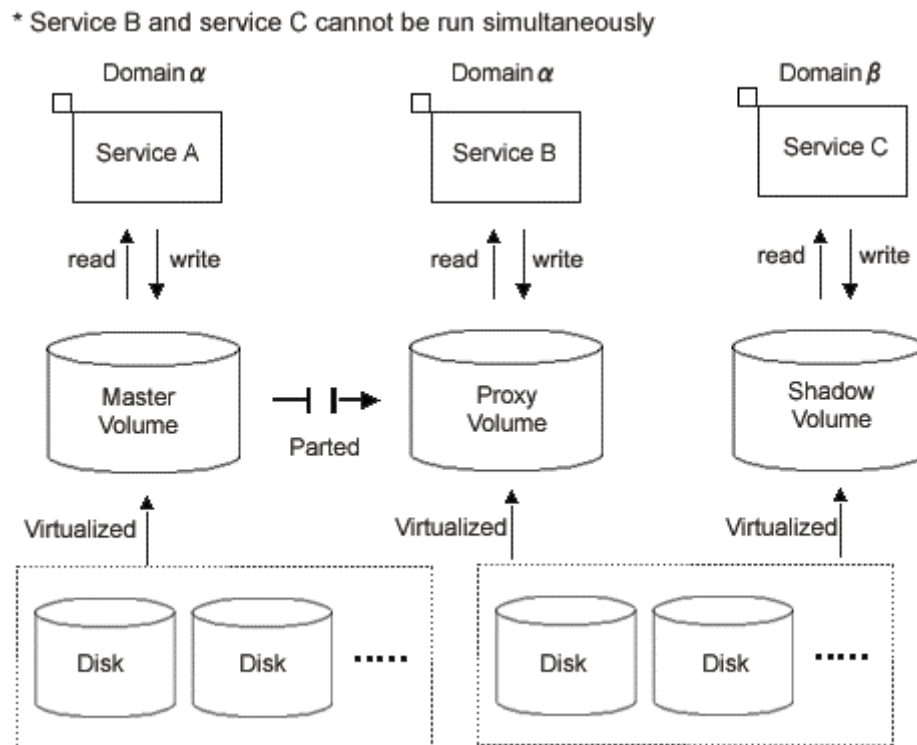

2.7.2.5 Shadow Slice

A shadow slice is a component of a shadow volume. A shadow volume of the mirror type consists of one or more mirrored shadow slices. A shadow volume of the single type, stripe type, or concatenation type consists of one shadow slice. A shadow slice is the shadow object corresponding to a logical slice that is an SDX object.

Independent access to a shadow slice detached from a shadow volume of the mirror type is unsupported.

When logical slices and shadow slices do not have to be classified particularly, they may be called "slices" collectively.

Attributes

A shadow slice has the following attributes.

Name

This attribute identifies the shadow slice within a shadow class.

Operation

Status Display

The slice status can be displayed with the `sdxinfo` command.

For details about GDS Management View, see "5.3.1 Viewing Configurations and Monitoring Statuses."

Status

ACTIVE

Data is accessible.

Here, the shadow volume is in the ACTIVE status. The total number of shadow slices in the ACTIVE or STOP status within a shadow volume of the mirror type indicates the present multiplicity of the mirroring configuration (1 to 8).

STOP

Data is inaccessible.

Here, the shadow volume is in the STOP status. The total number of shadow slices in the ACTIVE or STOP status within a shadow volume of the mirror type indicates the present multiplicity of the mirroring configuration (1 to 8).

INVALID

Data is inaccessible due to an I/O error.

When an I/O error is detected in a mirrored shadow slice, the shadow slice becomes INVALID.

For details, see "F.1.1 Slice Status Abnormality."

Chapter 3 Starting and Exiting GDS Management View

GDS Management View manages and monitors objects by using the Web browser. This chapter explains how to start and exit the GDS Management View.

GDS Management View uses Web-Based Admin View / WWW Server for Admin View.

For details about Web-Based Admin View / WWW Server for Admin View, see "Web-Based Admin View Operation Guide."

3.1 Preparation for Starting GDS Management View

In order to start GDS Management View, the following must be completed.

- Decide the user group.
- Set up the client environment.
- Set up the Web environment.

3.1.1 Deciding the User Group

In order to use GDS Management View, you must create user groups that the operating system manages and register the user names on all nodes where GDS are installed.

3.1.1.1 User Group Types

There are two types of user groups.

wvroot

"wvroot" is a Web-Based Admin View administrator group and is created automatically when Web-Based Admin View is installed. This permits availability of all kinds of operation management products running on Web-Based Admin View, such as GDS management, environment setup, logging view, and all.

sdxroot

This is the administrator group for GDS management. This user type can perform GDS Management View operations.

3.1.1.2 Creating User Groups

After installing the software, only user group wvroot will be automatically created. The other user group sdxroot, explained in "3.1.1.1 User Group Types" must be created as necessary. User group can be created using the following command.

```
# groupadd sdxroot
```

3.1.1.3 Registering to a User Group

You can register a user name to a user group with a command. Type an appropriate user group such as sdxroot, and execute the following command.

- **When registering an existing user to a user group**

- When registering a group to "Primary Group"

```
# usermod -g Group name(you wish to register) User name
```

- When registering a group to "Secondary Group"

```
# usermod -G Group name(you wish to register) User name
```

- **When registering a new user to a user group**

- When registering a group to "Primary Group"

```
# useradd -g Group name(you wish to register) User name
```

- When registering a group to "Secondary Group"

```
# useradd -G Group name(you wish to register) User name
```



Note

Registering a User to the wvroot Group

A user registered to the wvroot group will have the equivalent permission as a user assigned to the system administrator group. Only users responsible for the entire system should be registered to this group.

3.1.2 Setting up the Client Environment

Client hardware, OS and Web browser supported by GDS Management View is as follows.

PC Client

CPU

Pentium II 233MHz and above

RAM

minimum of 128MB

OS

Windows(R) 98, Windows(R) 98 Second Edition, Windows NT (R), Windows(R) 2000, Windows(R) Me, Windows(R) XP

Web Browser

Netscape Communicator 4.5 to 4.7X, Netscape 6.23, Netscape 7.1, Netscape 7.2, Internet Explorer 5.0 or higher.

(Web browsers need Java Plug-in.)

Java Plug-in

Java(TM) 2 Runtime Environment Standard Edition v1.3.1

Java(TM) 2 Runtime Environment Standard Edition v1.4.2

Display

800 * 600 dots and above, possible of displaying high color (16bit,65,536 colors)

Linux(R)

CPU

Pentium III and above

RAM

minimum of 256 MB

OS

Red Hat Enterprise Linux AS/ES (v.2.1)

Red Hat Enterprise Linux AS/ES (v.3)

SuSE SLES-7 (i386)

SuSE SLES-8 (i586)

Web Browser

For Red Hat Enterprise Linux AS/ES (v.2.1)

– Netscape Communicator 4.79

For Red Hat Enterprise Linux AS/ES (v.3)

– Netscape Communicator 7.1

– Netscape Communicator 7.2

For SuSE SLES-7 (i386)

– Netscape Communicator 4.77

For SuSE SLES-8 (i586)

– Netscape Communicator 4.80

– Netscape Communicator 6.23 (bundled Java Plug-in with Netscape Communicator 6.23)

Java Plug-in

For Red Hat Enterprise Linux AS/ES (v.2.1), SuSE SLES-7, SuSE SLES-8

– IBM(R) Runtime Environment for Linux(R), Java(TM) 2 Technology Edition, Version 1.3.1, 32-bit version

For Red Hat Enterprise Linux AS/ES (v.3)

– Java(TM) 2 Runtime Environment, Standard Edition, Version 1.4.2

3.1.3 Setting up the Web Environment

In order to use GDS Management View, you must define the environment for the client and the Web browser. For details about setting the Web browser, see "Web-Based Admin View Operation Guide."

3.2 Starting the GDS Management View

Start the GDS Management View after all the necessary settings are complete.

3.2.1 Starting Web-Based Admin View Operation Menu

Follow the procedures below to start Web-Based Admin View.

Procedures

1. Start the Web browser on your client.
2. Access the management server by specifying the following URL

When using Java Plug-in.

`http://host name:port number/Plugin.cgi`

host name

Specify the public LAN IP address for the primary or secondary management server, or host name.

port number

Specify "8081." When the port number has been changed, specify the new port number.



See

For details about changing port numbers, see "Web-Based Admin View Operation Guide."



Note When the Web-Based Admin View does not start

If you specified the management server's host name for "host name", and the Web-Based Admin View does not start, specify the public LAN IP address instead.

3. After starting the Web-Based Admin View, the following user input screen appears.
- 4.

Figure: User Name Input Screen

The screenshot shows a Java applet window titled "Web-Based Admin View". It has a standard Windows-style title bar with minimize, maximize, and close buttons. The main area contains two text input fields: "User name:" and "Password:". Below these fields is a single "OK" button. At the bottom of the window, there is a status bar that reads "Unsigned Java Applet Window".

Type the user name and password for the management server, and press <OK>.

5. After completing authentication, the top menu of Web-Based Admin View appears.

3.2.2 Web-Based Admin View Operation Menu Functions

The Web-Based Admin View screen supports the following facilities.

Menu	Outline
Global Disk Services	Start the GDS Management View.

See "Web-Based Admin View Operation Guide" about other operation menus.

Figure: Web-Based Admin View Operation Menu(Top Menu)

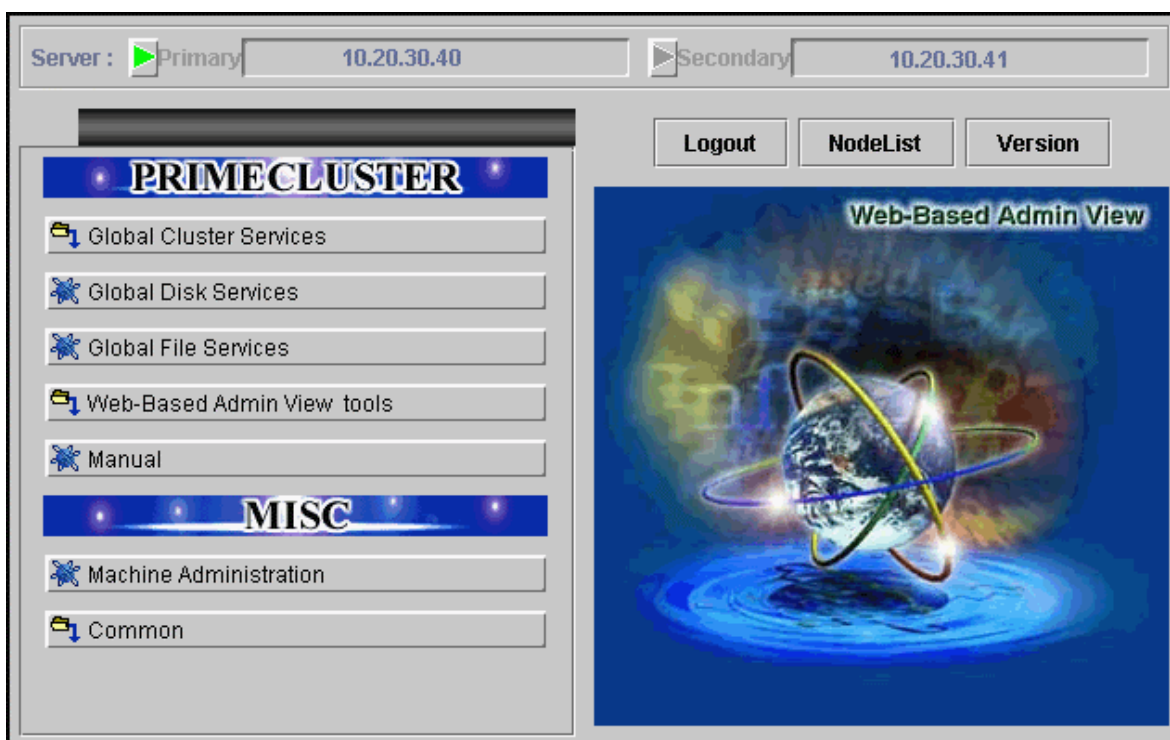

Note The state of Web-Based Admin View Operation Menu

- The Web-Based Admin View menu varies depending on the products installed.
- If a dialog is displayed because of a Web-Based Admin View error, the picture on the right area of the screen turns red. Click the red picture, and then a hidden dialog is brought to the front. As any errors come into focus, be sure to make the picture viewable.

3.2.3 Starting GDS Management View

Click the GDS management icon on the Web-Based Admin View Operation menu to start the GDS Management screen (hereinafter main screen).

From the main screen, you can perform GDS object configuration, such as a class or a volume, status confirmation, and disk swap.

For details, see "Chapter 5 Operation"

Figure: GDS Management Main Screen

The screenshot displays the GDS Management Main Screen. The interface is divided into several sections:

- Configuration Tree (Left):** A hierarchical tree view showing the structure of GDS objects. It includes nodes for 'linux04', 'class0001', 'group0001', 'group0003', 'class0002', 'Mastergrp001', 'Proxygrp', and 'disksd0010'.
- Volume Information (Center):** A table listing the details of various volumes. The columns are Volume Name, Status, Class Name, Size, JRM, Physical Slice, Type, and Master.
- Disk Information (Bottom):** A table listing the details of physical disks. The columns are Disk Name, Status, Physical Disk, Group Name, and Disk Type.
- Log Information (Bottom):** A section for viewing system logs, currently empty.

Volume Name	Status	Class Name	Size	JRM	Physical Slice	Type	Master
volume0001	active	class0001	0.25 GB	off	off	stripe	-----
volume0002	active	class0001	0.25 GB	on	on	mirror	-----
volume0003	active	class0001	0.51 GB	on	on	mirror	-----
Mstervol	active	class0002	0.25 GB	on	on	mirror	-----
Mstervol2	active	class0002	0.25 GB	on	off	mirror	-----
mstervol3	active	class0002	0.25 GB	off	off	mirror	-----
Mstervol4	stop	class0002	0.25 GB	on	on	mirror	-----
Mstervol_Proxygrp	stop	class0002	0.25 GB	on	on	mirror	-----
Mstervol2_Proxyg...	stop	class0002	0.25 GB	on	off	mirror	-----
mstervol3_Proxy...	stop	class0002	0.25 GB	on	off	mirror	-----

Disk Name	Status	Physical Disk	Group Name	Disk Type
disksd0001	enabled	sdaa	group0001	stripe
disksd0002	enabled	sdab	group0001	stripe
disksd0003	enabled	sdac	group0002	concat
disksd0004	enabled	sdad	group0002	concat
disksd0005	enabled	sdae	group0003	mirror
disksd0006	enabled	sdaf	group0003	mirror
disksd0007	enabled	sdag	Mastergrp001	mirror
disksd0008	enabled	sdah	Mastergrp001	mirror
disksd0009	enabled	sdai	Proxygrp	mirror
disksd0010	enabled	sdaj	-----	single

3.3 Exiting GDS Management View

How to exit the GDS Management View is described below.
On the [General] menu, click [Exit]. The following message appear

Figure: Exit Message

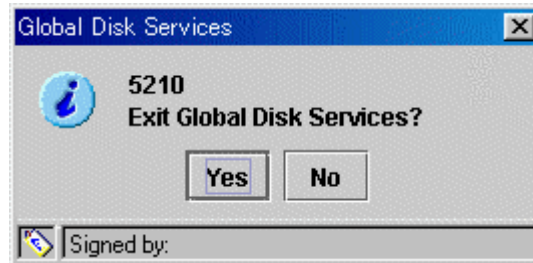

Press <Yes>, and Web-Based Admin View (top menu) appears.
Press <No>, and you will return to the main screen.

How to exit Web-Based Admin View is described below.

- Press <Log Out> from one of the following menus; top menu, GDS Management Operation menu, or Common Operation menu.
- Log In screen appears. Exit the browser, or press Back on the browser and exit GUI.



Note **When the login screen remains displayed**

After exiting the Web browser, the login screen may remain displayed for a while. Since it will soon disappear, there is no need to do anything.

3.4 Changing the Web-Based Admin View Settings

When changing one of the following settings after installing Web-Based Admin View, see "Web-Based Admin View Operation Guide" for details.

- Modifying the IP address of the public LAN
- Modifying the port number of the network service
- Changing the management server
- Modifying the operation of the secondary management server
- Modify the network environment in the management server

Chapter 4 Management View Screen Elements

This chapter explains the screen elements of GDS Management View.
Screen elements refer to the following items:

- screen configuration
- menu configuration and functions
- icon types and object status
- object information

4.1 Screen Configuration

Main Screen

Click <Global Disk Services> from Web-Based Admin View, and the screen below appears.

From the main screen, you can perform GDS object configuration, such as a class and a volume, status confirmation, and disk swap.

You can also configure and view the statuses of GDS Snapshot proxy objects and shadow objects and also operate those proxy objects.

The following operations are unsupported. Use commands for these operations.

- Object operations in classes that include switch groups (Information of relevant objects is displayed in blue.)
- Operations of GDS Snapshot shadow objects (Information of relevant objects is displayed in italic format.)

The screen configuration of the main screen is shown below.

Figure: GDS Management Screen (Main Screen)

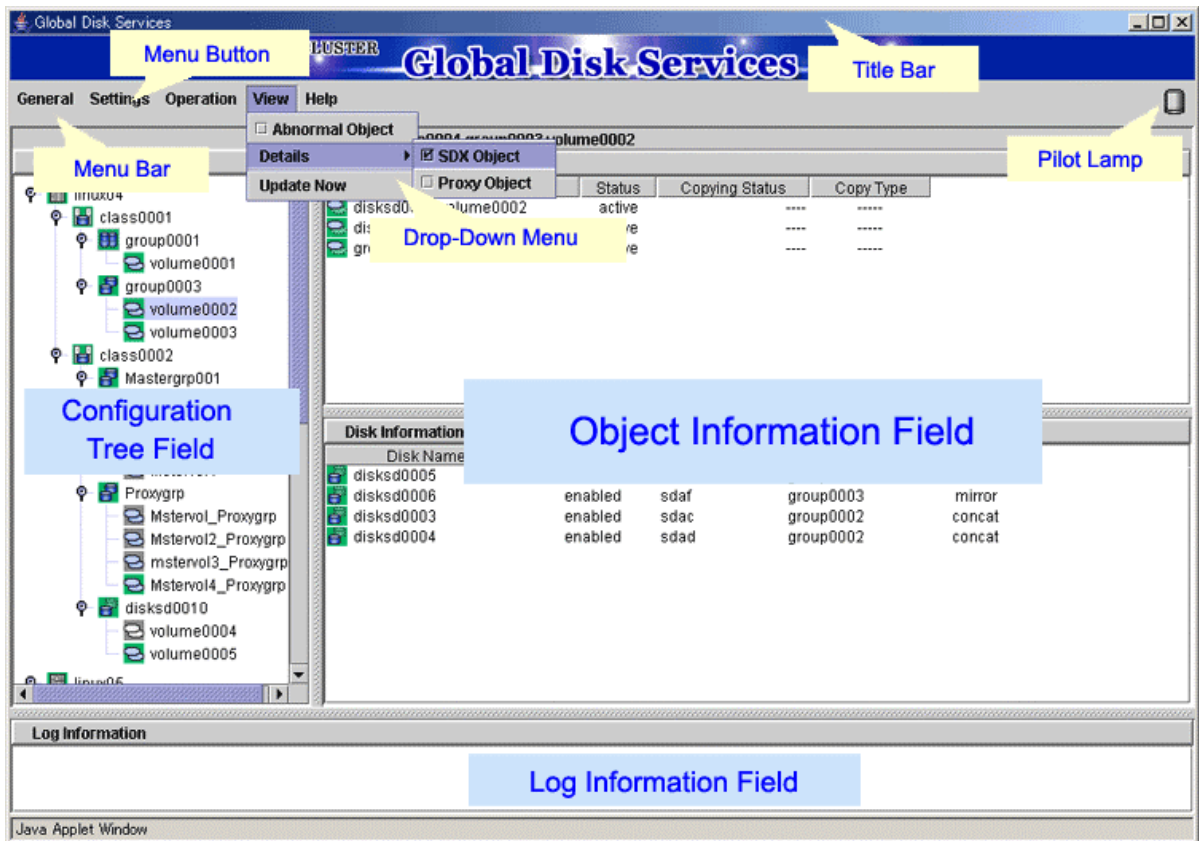

Configuration Tree Field

Objects managed with GDS are displayed in a tree-structured directory system. Each object has an icon depicting the type and the status of the object.

For details about the icon type and status, see "4.3 Icon Types and Object Status."

By selecting the node in the GDS configuration tree field, you can switch between the nodes you want to display or operate.

Object Information Field

Detailed information of objects is displayed in table format.
The displayed contents vary according to the menus selected in [View]:[Details] and the object types selected on the GDS configuration tree.
For details about displayed contents, see "4.4 Object Information."

Log Information Field

Displays error message output by the GDS daemon program.

Title Bar

Displays screen title (Global Disk Services).

Menu Bar

Displays the menu buttons.

Menu Button





Allows you to control the objects selected on screen. There are [General], [Settings], [Operation], [View] and [Help].

Drop-Down Menu

When a menu button from the menu bar is selected, a drop-down menu will be displayed.
For details about drop-down menu, see "4.2 Menu Configuration and Functions."

Pilot Lamp

Shows the status of the monitored objects.
The lamp will indicate the following status.

Pilot Lamp	Status	Meaning
 (Gray lit up)	Normal	Normal status.
 (Red blinking)	Abnormal	Critical abnormality (e.g. closed class, invalid volume)
 (Red lit up)	Abnormal	When red blinking warning lamp is single-clicked.
 (Yellow blinking)	Degradation	<ul style="list-style-type: none">Volume operating at degradation. (e.g. invalid slice, disabled disk)Disk I/O error
 (Yellow lit up)	Degradation	When yellow blinking warning lamp is single-clicked.

GDS Configuration Settings screen

Select Configuration from [Settings] menu, and the "GDS Configuration Settings screen" shown below will appear.

Use the <Screen Switching Tab> to switch between "Class Configuration", "Group Configuration", and "Volume Configuration" settings screens.

Figure: GDS Configuration Settings Screen

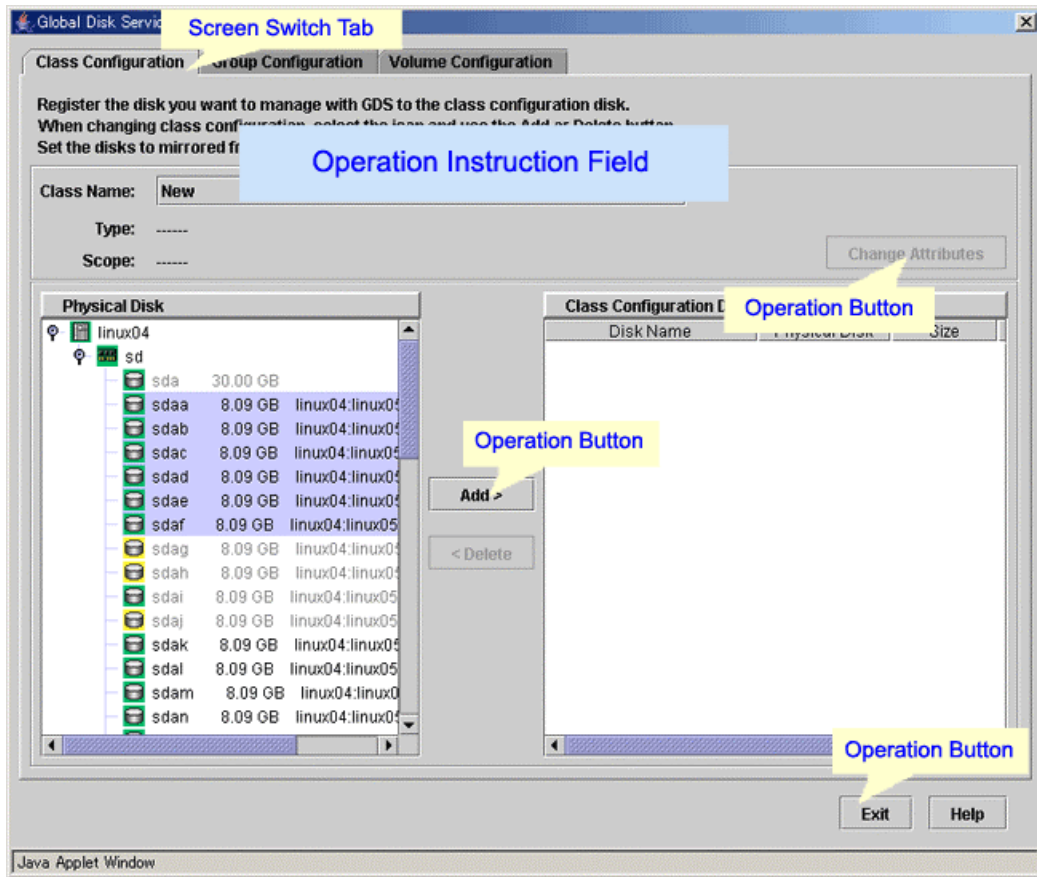

For information on how to set each configuration, see "5.2.1 Operating from the Settings Menu."

4.2 Menu Configuration and Functions

Each menu button has a drop-down menu allowing you to operate the selected object on screen. This section explains the menu configuration and functions. The operations for shadow objects available with GDS Snapshot are not supported.

4.2.1 General



Change Monitoring Intervals

Sets the monitoring interval (in minutes) of objects.

Figure: [General]: [Change Monitoring Intervals] Screen



Note When Changing Monitoring Intervals

The default value for monitoring intervals is 5 minutes. When GDS Management is restarted, the monitoring interval is initialized to 5 minutes. To change the monitoring interval, modify the monitoring interval value each time GDS Management is restarted.

Exit

Exits GDS Management.

Figure: [General]: [Exit] Screen

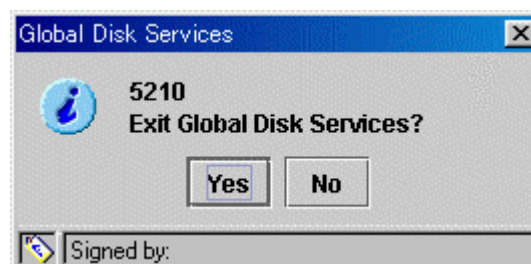

4.2.2 Settings



Class Configuration

Sets the class configuration.

For details, see "5.2.1 Operating from the Settings Menu."

Figure: [Settings]: [Class Configuration] Screen

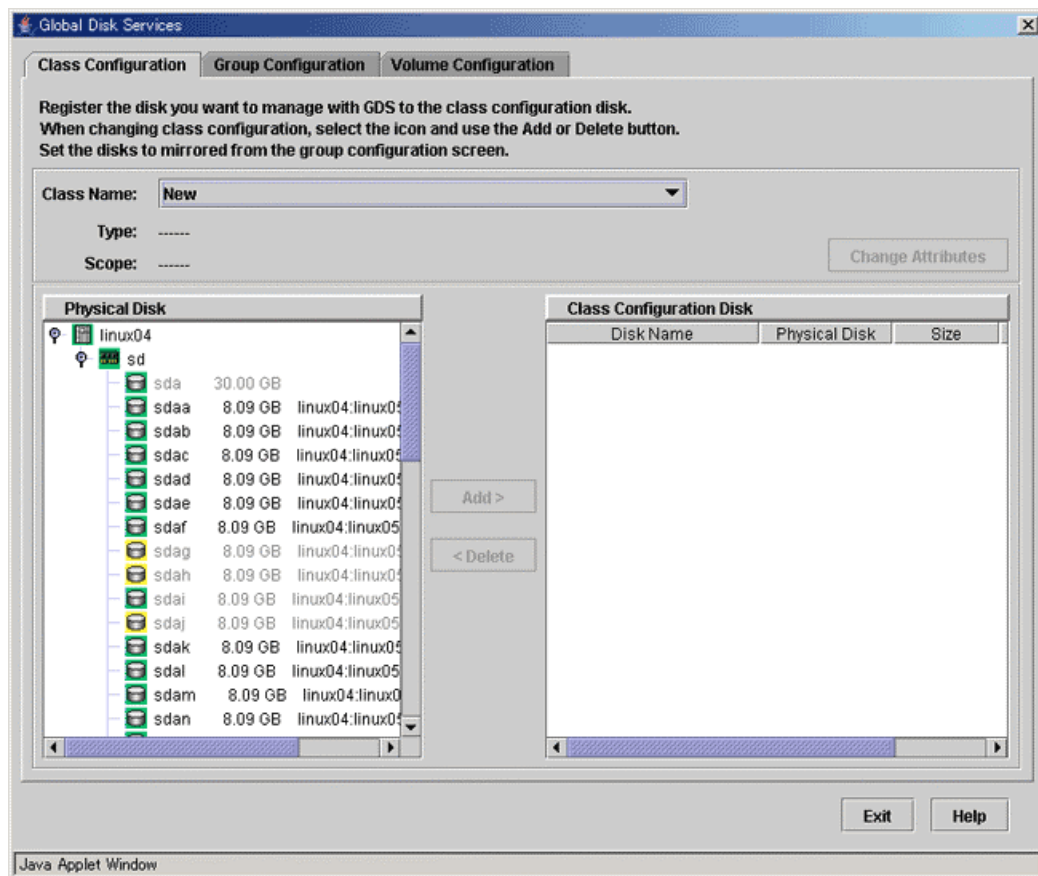

Group Configuration

Sets the group configuration.

For details, see "5.2.1 Operating from the Settings Menu."

Figure: [Settings]: [Group Configuration] Screen

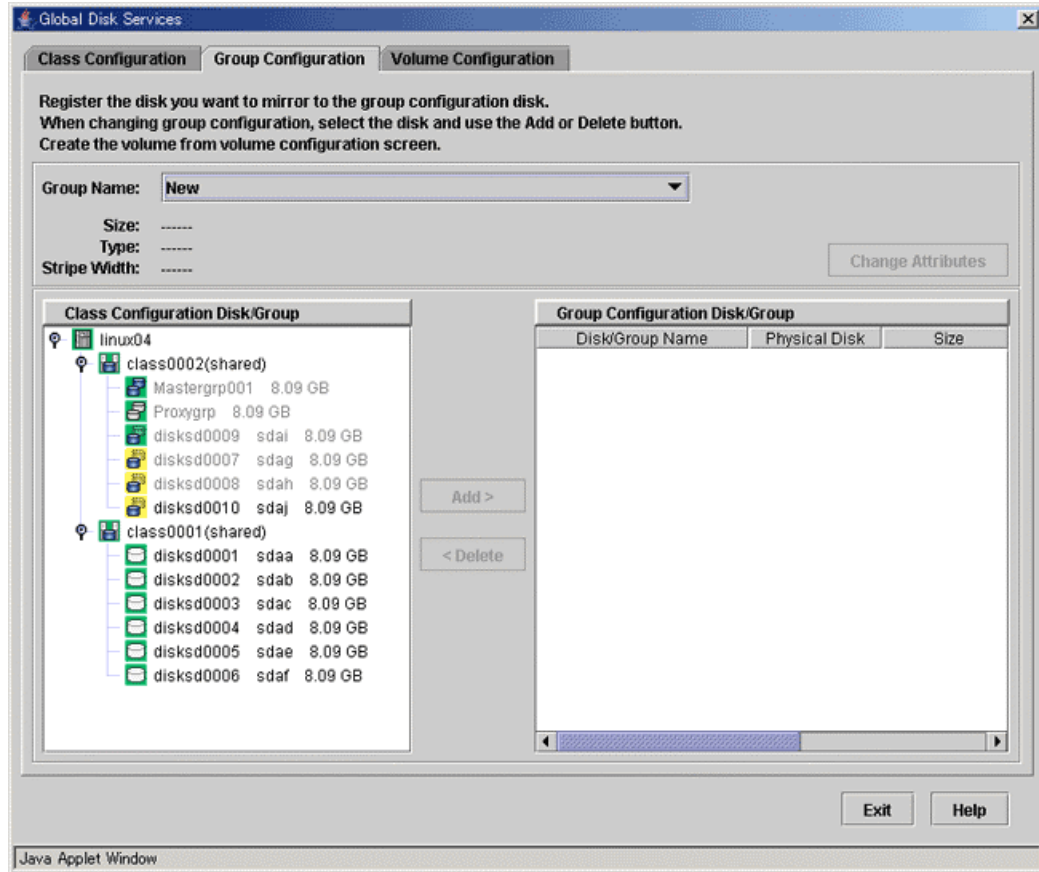

Volume Configuration

Sets the volume configuration.
For details, see "5.2.1 Operating from the Settings Menu."

Figure: [Settings]: [Volume Configuration] Screen

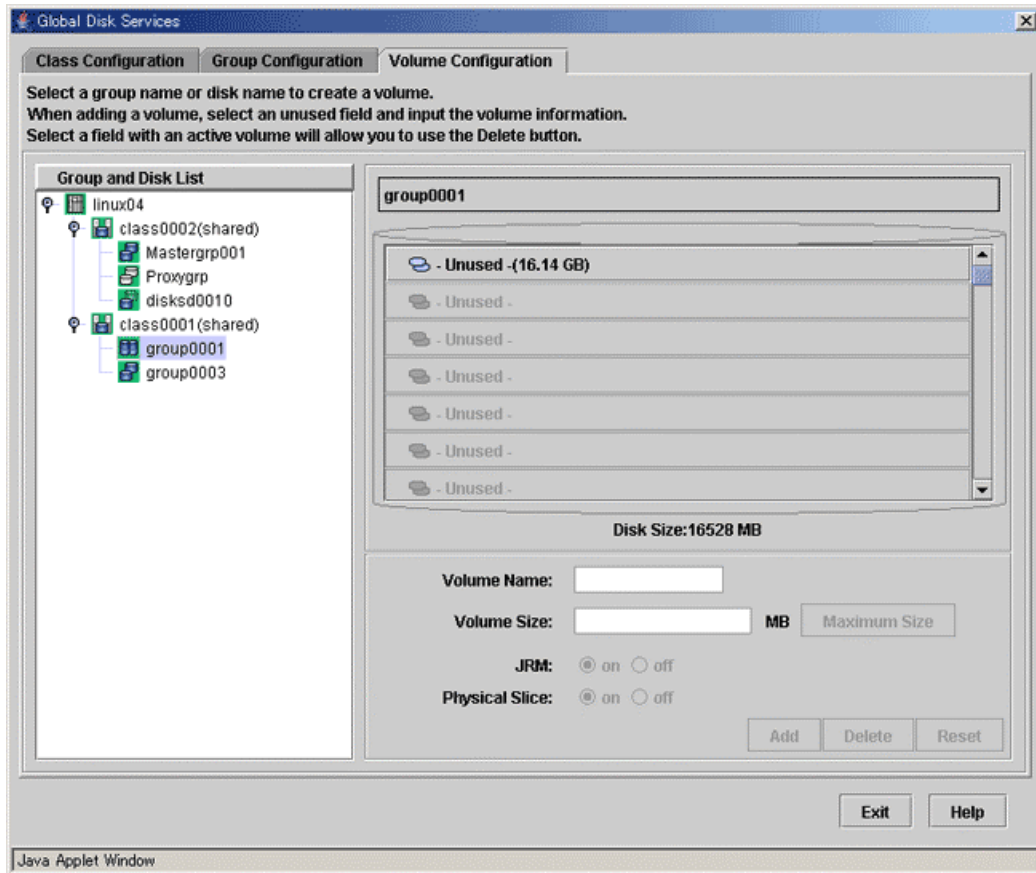

File System Configuration

Sets the file system configuration.

For details, see "5.2.2 File System Configuration."

Figure: [Settings]: [File System Configuration] Screen

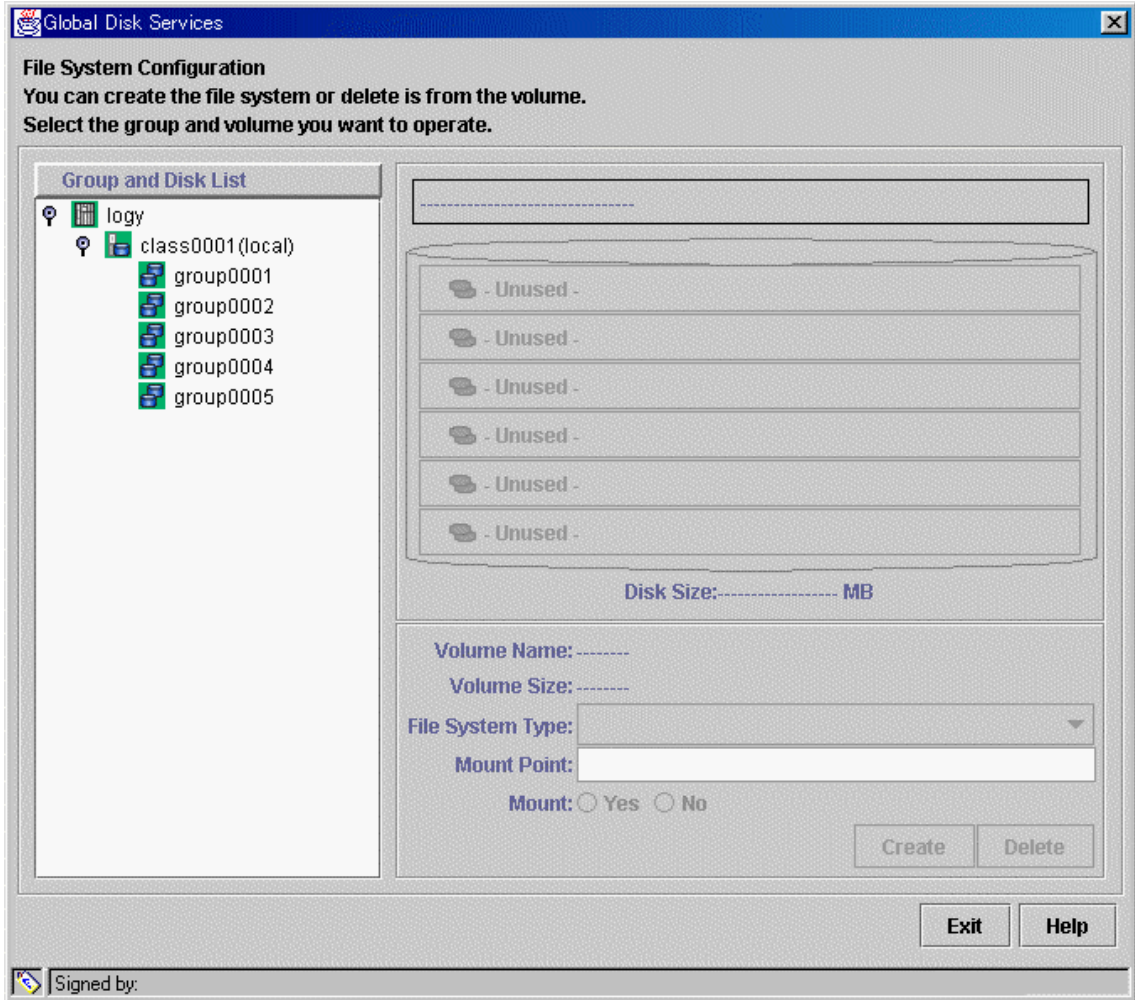

4.2.3 Operation

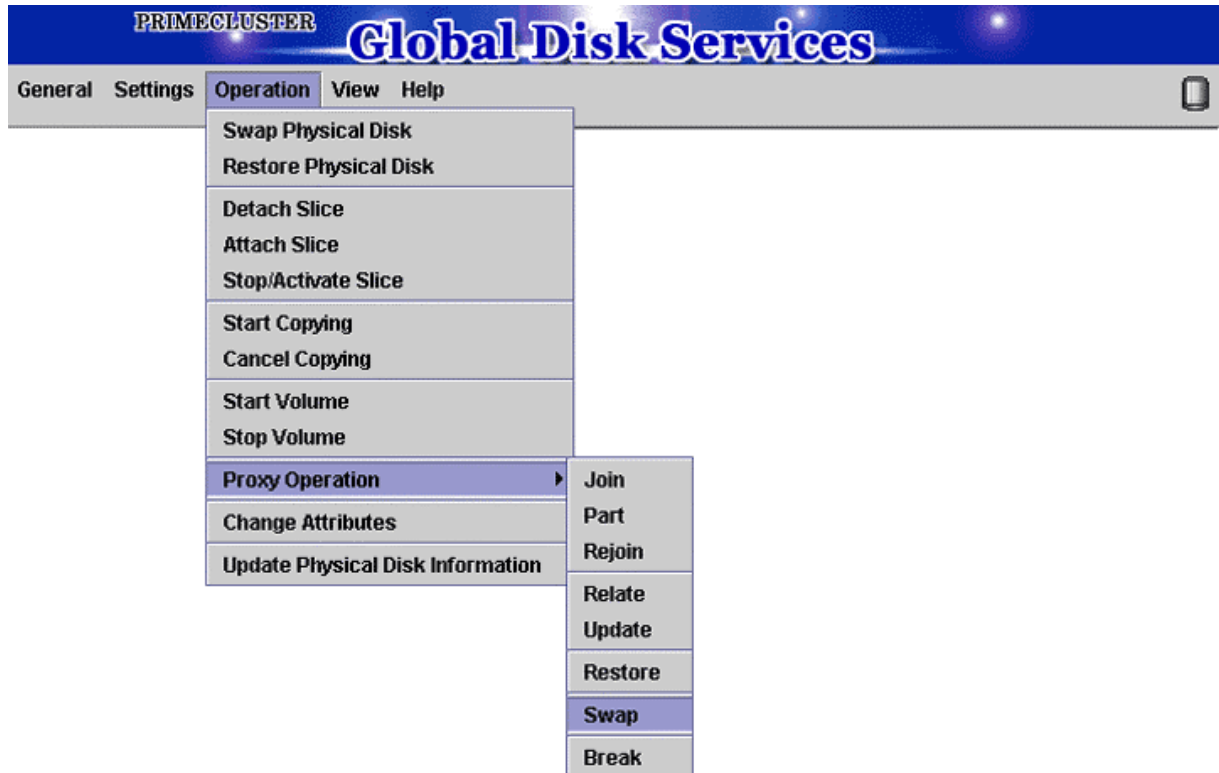

Swap Physical Disk

Places the physical disk off-line when swapping physical disks.
For details, see "5.3.4 Disk Swap."

Restore Physical Disk

Places the swapped physical disk on-line for restoration, after swapping the physical disks.
For details, see "5.3.4 Disk Swap."

Detach Slice

Detaches one of the slices from Mirror volume to prepare for backup.
The detached slice will become accessible as a separate logical device.
For details, see "5.3.2.1 Backup (by Slice Detachment)."

Attach Slice

Slice detached by [Detach Slice] is attached to Mirror volume again.
For details, see "5.3.2.1 Backup (by Slice Detachment)."

Stop/Activate Slice

Stop Slice

In order to protect data of the slice which has been detached to prepare for backup, a slice with "temp" status will temporarily become inaccessible.

Activate Slice

The detached slice which is now inaccessible ("temp-stop" status) as a result of [Stop Slice] operation or switching of nodes will be reactivated and become accessible.

For details, see "5.3.2.1 Backup (by Slice Detachment)."

Start Copying

A slice with "invalid" or "copy-stop" status as a result of [Cancel Copying] operation will be attached to a mirror volume, and synchronization copying will be performed.
For details, see "5.3.6 Copying Operation."

Cancel Copying

Execution of copying will be stopped to avoid effects caused by accessing the disk in the process of synchronization copying.
For details, see "5.3.6 Copying Operation."

Start Volume

Starts the stopped volume.

Stop Volume

Stops the volume.

Proxy Operation

Operates proxy objects. This menu is available only if GDS Snapshot is installed.

Join

Relates proxy objects to master objects and synchronizes them as preparation for snapshot creation by synchronization, or online disk migration.
For details, see "5.2.3.1 Join."

Part

Parts joined proxies from masters temporarily to make them accessible as logical devices that are different from the masters for snapshot creation by synchronization. The parted proxies can be used as snapshots (replicas) of the masters at the moment.
For details, see "5.3.2.2 Backup (by Synchronization)."

Rejoin

Joins parted proxies to masters again and synchronizes them as preparation for snapshot re-creation by synchronization.
For details, see "5.3.2.2 Backup (by Synchronization)."

Relate

Relates proxy objects to master objects and parts them as preparation for snapshot creation by OPC.
For details, see "5.2.3.2 Relate."

Update

Copies (overwrites) data from masters to parted proxies for snapshot creation by OPC. The updated proxies can be used as snapshots (replicas) of the masters at the moment.
For details, see "5.3.2.3 Backup (by OPC)."

Restore

Copies (overwrites) data from parted proxies to masters for restoration of damaged master data. The masters are recovered by the proxy data at the moment.
For details, see "5.3.3 Restore."

Swap

Swaps slices of synchronized masters and proxies for online disk migration.
For details, see "5.3.5 Disk Migration."

Break

Breaks the relationships between masters and proxies and makes them unrelated again.
For details, see "5.5.5 Breaking a Proxy."

Change Attributes

Changes the attributes of the selected object.
For details, see "5.4 Changes."

Update Physical Disk Information

You can update the disk information without rebooting the system. This feature is useful in the situations given below.

- When physical disk size is not displayed properly.
- When you turn on the disk array or the disk unit after booting the system.
- When the disk has become inaccessible while operating the system.
- When the configuration of devices such as mphd or mplb has been changed.

4.2.4 View



Abnormal Object

Only displays objects with abnormalities; not all objects.

Details

Changes displayed contents in the Object Information Field.
By default, [SDX Object] is selected.

SDX Object

Displays information of volumes, disks and slices.

Proxy Object

Displays information of proxy volumes, proxy groups and slices.

For details about the Objects Information Field, see " 4.4 Object Information "

Update Now

Usually, GDS Management screen updates the information on object status at an interval specified by [Change Monitoring Intervals] in the [General] menu.

If you select [Update Now], object status will be updated immediately regardless to the interval specified by [Change Monitoring Intervals].

In order to recognize the disk again, select [Update Physical Disk Information] from [Operation] menu.

4.2.5 Help



Help

Displays Help information.

4.3 Icon Types and Object Status

GDS Management uses icons to show the status of the objects.





Information

The SDX objects that belong to GDS classes and the shadow objects that belong to GDS Snapshot shadow classes are distinguished by fonts. Information related to shadow objects is displayed in italics.

The status and the icons of objects are shown below.



1. Node

Icon	Status	Meaning
 (Green)	Normal	-
 (Yellow)	Abnormal	Abnormality within the node.
 (Red)	Abnormal	Abnormality of the node.



2. Adapter

Icon	Status	Meaning
 (Green)	-	-



3. Class (shared)

Icon	Status	Meaning
 (Green)	Normal	-
 (Yellow)	Abnormal	Abnormality within the (shared) class.
 (Red)	Closed	Closed class within the class.



4. Shadow Class (local)

Icon	Status	Meaning
 (Green)	Normal	-
 (Yellow)	Abnormal	Abnormality within the (root) class.



5. Group (mirror)

Icon	Status	Meaning
 (Green)	Normal	-
 (Yellow)	Abnormal	Abnormality within the (mirror) group.
 (Red)	Abnormal	Closed class within a class to which the (mirror) group belongs.



6. Group (stripe)

Icon	Status	Meaning
 (Green)	Normal	-
 (Yellow)	Abnormal	Abnormality within the (stripe) group.
 (Red)	Abnormal	Closed class within a class to which the (stripe) group belongs.

7. Group (concat)

Icon	Status	Meaning
 (Green)	Normal	-
 (Yellow)	Abnormal	Abnormality within the (concat) group.
 (Red)	Abnormal	Closed class within a class to which the (concat) group belongs.







8. Group (switch)

Icon	Status	Meaning
 (Green)	Normal	-
 (Yellow)	Abnormal	Abnormality within the (switch) group.
 (Red)	Abnormal	Closed class within a class to which the (switch) group belongs.





9. Physical Disk

Icon	Status	Meaning
 (Green)	-	-





10. Disk connected to the group

Icon	Status	Meaning
 (Green)	enabled	Operation enabled.
 (Yellow)	enabled	Some volumes or slices with status other than active.
 (Red)	enabled	I/O error on the disk.
 (Red)	disabled	Operation disabled.
 (Red)	close	Closed class within a class to which the disk belongs.
 (Light Brown)	swap	Disk swap possible.





11. Single Disk

Icon	Status	Meaning
 (Green)	enabled	Operation enabled.
 (Yellow)	enabled	Some volumes or slices with status other than active.
 (Red)	enabled	I/O error on the disk.
 (Red)	disabled	Operation disabled.
 (Red)	close	Closed class within a class to which the single disk belongs.







12. Spare Disk

Icon	Status	Meaning
 (Green)	enabled	Operation enabled.
 (Yellow)	enabled	Some volumes or slices with status other than active.
 (Red)	enabled	I/O error on the disk.
 (Red)	close	Closed class within a class to which the spare disk belongs.
 (Light Brown)	swap	Disk swap possible.









13. Unused Disk

Icon	Status	Meaning
 (Green)	enabled	Operation enabled.
 (Red)	enabled	I/O error on the disk.
 (Red)	disabled	Operation disabled.
 (Red)	close	Closed class within a class to which the unused disk belongs.
 (Light Brown)	swap	Disk swap possible.







14. Volume

Icon	Status	Meaning
 (Green)	active	Active volume.
 (Yellow)	copy	Copying
 (Yellow)	warning	Object status of some slices is a status other than active. (except copying)
 (Black)	stop	Volume stopped.
 (Red)	invalid	Abnormality of volume.
 (Red)	close	Closed class within a class to which the volume belongs.



15. Slice

Icon	Status	Meaning
 (Green)	active	Active slice.
 (Black)	stop	Slice stopped.
 (Red)	invalid	Abnormality of slice. (Invalid data)
 (Red)	close	Closed class within a class to which the slice belongs.
 (Blue)	copy	Copying
 (Blue)	copy-stop	Synchronization copying temporarily interrupted.
 (Light Blue)	temp	Slice temporarily excluded. (accessible)
 (Light Blue)	temp-stop	Slice temporarily excluded. (inaccessible)
 (Light Brown)	nouse	Operation disabled.

16. Proxy volume

Icon	Status	Meaning
 (Green)	active	Active proxy volume.
 (Yellow)	copy	Copying
 (Yellow)	warning	Object status of some slices is a status other than active. (except copying)
 (Black)	stop	Proxy volume stopped.
 (Red)	invalid	Abnormality of proxy volume.
 (Red)	close	Closed class within a class to which the proxy volume belongs.

17. Proxy group

Icon	Status	Meaning
 (Green)	Normal	-
 (Yellow)	Abnormal	Abnormality within the group.
 (Red)	Abnormal	Closed class within a class to which the group belongs.



Note **Abnormality Detected with GDS Management**

What GDS Management displays as abnormal is limited to objects detected by GDS.

Therefore, even if the disk unit may have a hardware abnormality, it will be displayed as normal until it is accessed, and then abnormality is detected.

You should pinpoint the hardware error on a disk unit based on, for example, log messages for the disk driver output in the /var/log/messages file. For details, see "F.1.9 Disk Unit Errors."

4.4 Object Information

This section describes information displayed in the Main Screen's Object Information Field.

The displayed contents in the Object Information Field vary according to the menus selected in [View]:[Details] and the object types selected on the GDS configuration tree.

By default, [View]:[Details]:[SDX Object] is selected.

- [View]:[Details]:[SDX Object] shows:

GDS Configuration Tree Object	Object Information Field (Upper)	Object Information Field (Lower)
Volume	Slice information	Disk information
Non-volume	Volume information	Disk information

- [View]:[Details]:[Proxy Object] shows:

GDS Configuration Tree Object	Object Information Field (Upper)	Object Information Field (Lower)
Volume	Proxy volume information	Slice information
Non-volume	Proxy group information	Proxy volume information

The Object Information Field displays the following information.

Field Name	Displayed Information
Volume Information	Volume name, status, assigned class name, size, JRM mode, physical slice attribute, type, master volume name
Disk Information	Disk name, status, physical disk name, assigned group name, type
Slice Information	Slice name, status, copy status, master-proxy GDS Snapshot copy type
Proxy Volume Information	Proxy volume name, master volume name, status, snapshot creation time (last parted or updated time), JRM (for rejoin and restore) mode
Proxy Group Information	Proxy group name, master group name

Chapter 5 Operation

This chapter describes the GDS operations from GDS Management View.

From GDS Management View, you can configure, operate, reconfigure, delete, view the configuration of, and monitor the status of GDS objects (SDX objects). If GDS Snapshot is installed, you can also operate proxy objects and view their configurations and statuses. For shadow objects, configuration viewing and status monitoring only are possible.

For details about operations supported in GDS Management View, see "5.1.7 Operations from GDS Management View."

5.1 Operation Outline

This section explains the GDS settings and operation management.



Note **Resource registration of shared disks**

Before defining the configuration of GDS objects such as classes and volumes, perform the following procedures.

1) Automatic Resource Registration

Conduct PRIMECLUSTER automatic resource registration. Similar procedures are also required when shared disks are not managed, but only system disks and local disks are managed. For details about resource registration, see "Appendix H Register shared disk units."

2) Physical Disk Information Update

To register MPHD disks or MPLB disks with classes, after conducting automatic resource registration, execute [Update Physical Disk Information] in the [Operation] menu in GDS Management View.

5.1.1 Configuration Settings

Use relevant menus for configuration.

The setting procedures differ depending on the type of volume you are creating.

- Single volume configuration settings
- Other volume (mirror volume, stripe volume, volume in a concatenation group) configuration settings

Switch volume creation from GDS Management View is unsupported. For creating those volumes, use commands.

5.1.1.1 Single Volume Configuration Settings

The operation outline of single volume configuration settings is shown below.

Chart: Single Volume Configuration Settings Operation

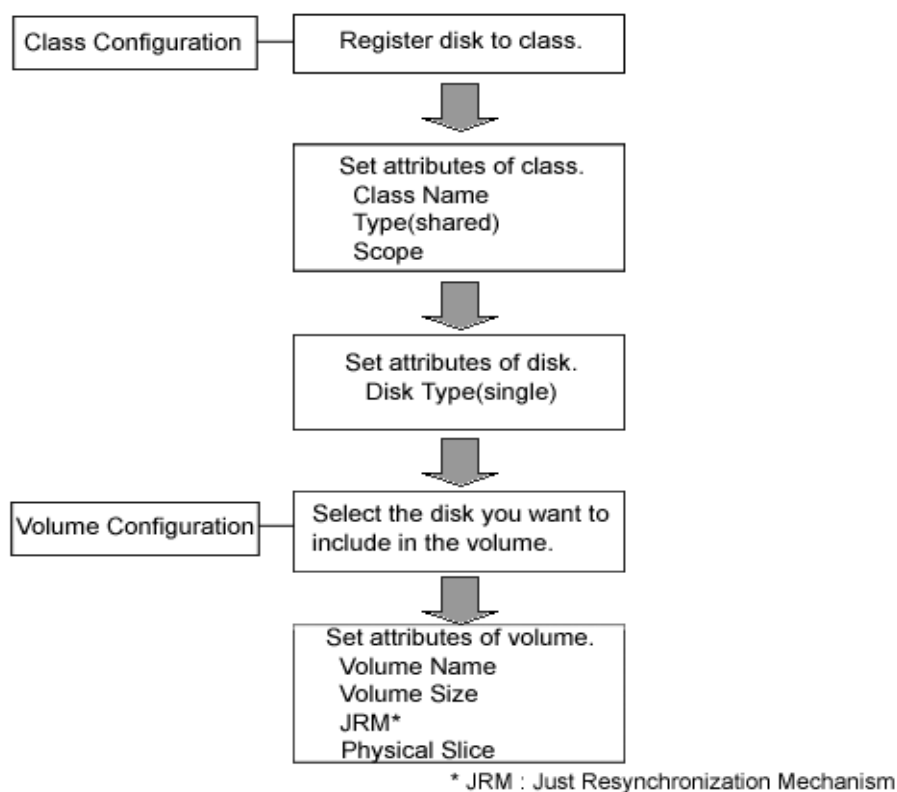

See

For details about the operation methods, see "5.2.1 Operating from the Settings Menu."

5.1.1.2 Other Volume Configuration Settings

The operation outline of the configuration settings for volumes other than single volume (mirror volume, stripe volume, volume in a concatenation group) is shown below.

Switch volume creation from GDS Management View is unsupported. For creating those volumes, use commands.

Chart: Volume Configuration Settings Operation

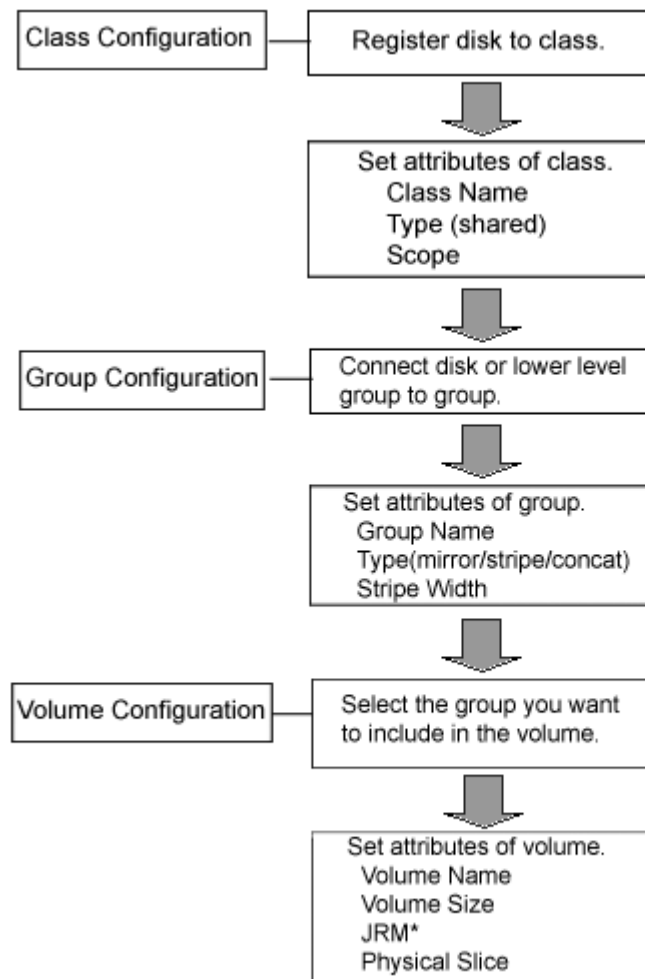

* JRM : Just Resynchronization Mechanism



See

For details about the operation methods, see "5.2.1 Operating from the Settings Menu."

5.1.2 Backup

Volumes can be backed up while applications using them are running.

The following three backup methods are available.

- Slice detachment
- Synchronization
- OPC

5.1.2.1 Backup (by Slice Detachment)

The following figure shows the procedures for backing up mirror volumes through snapshot by slice detachment.

Chart: Backup Operation (by Slice Detachment)

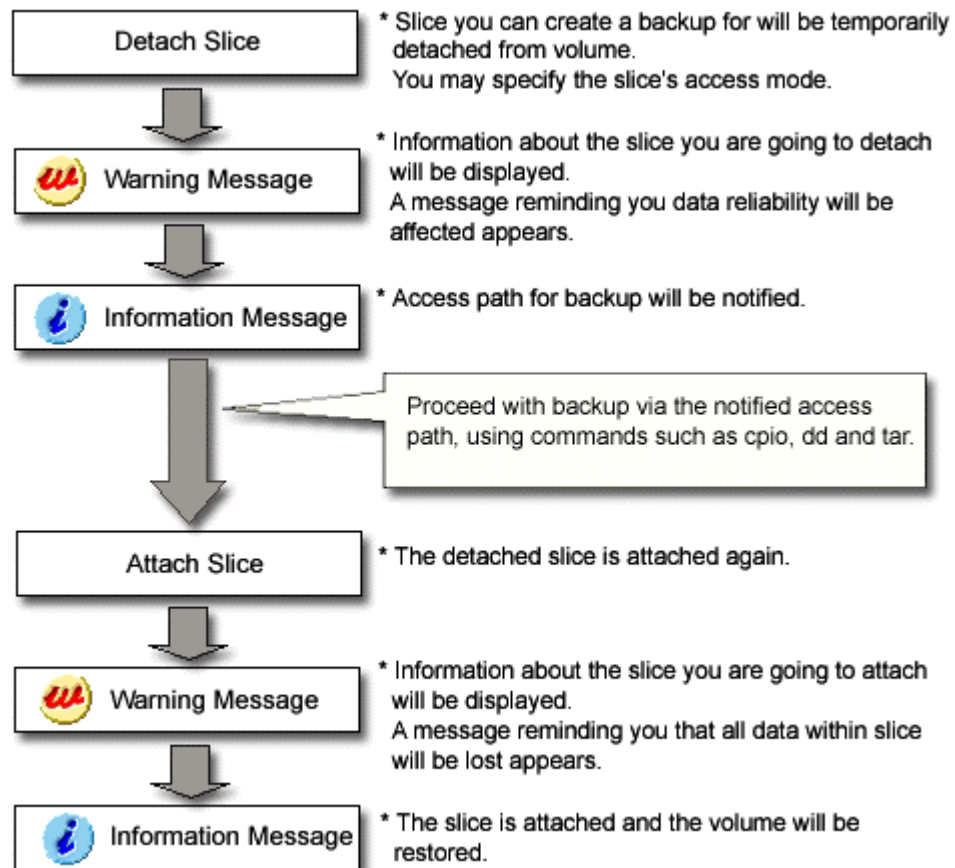

Note Use Conditions on Snapshot by Slice Detachment

Slices can be detached only from mirror volumes with physical slices. In other words, if disks are not connected directly to mirror groups, creation of snapshots by slice detachment is impossible.



See

For details about the operation methods, see "5.3.2.1 Backup (by Slice Detachment)."

5.1.2.2 Backup (by Synchronization)

The following figure shows the procedures for backing up volumes through use of snapshots (proxy volumes) of GDS Snapshot created by synchronization.

Chart: Backup Operation (by Synchronization)

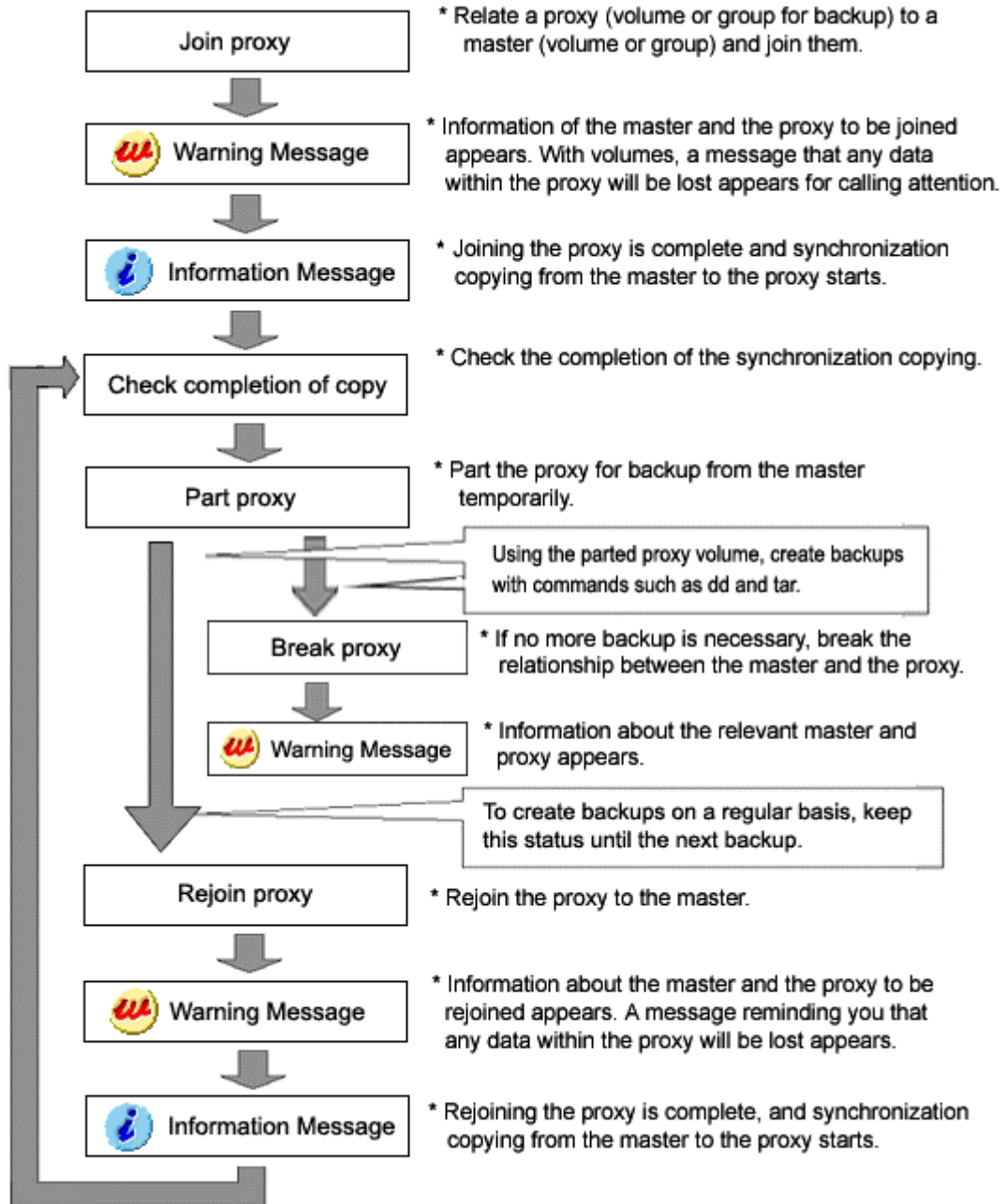

See

For details about the operation methods, see "5.3.2.2 Backup (by Synchronization)."

5.1.2.3 Backup (by OPC)

The following figure shows the procedures for backing up volumes through use of snapshots (proxy volumes) of GDS Snapshot created by OPC.

Chart: Backup Operation (by OPC)

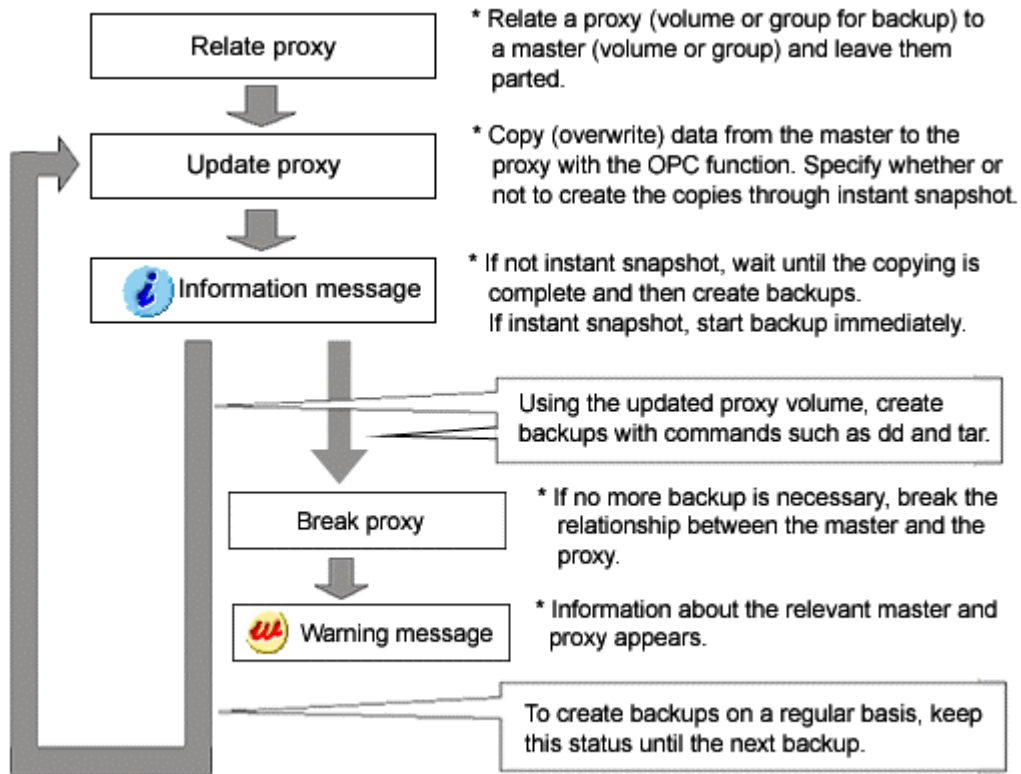

See

For details about the operation methods, see "5.3.2.3 Backup (by OPC)."

5.1.3 Restore

The following figure shows the procedures for restoring volumes through use of GDS Snapshot proxy volumes.

Chart: Restore Operation

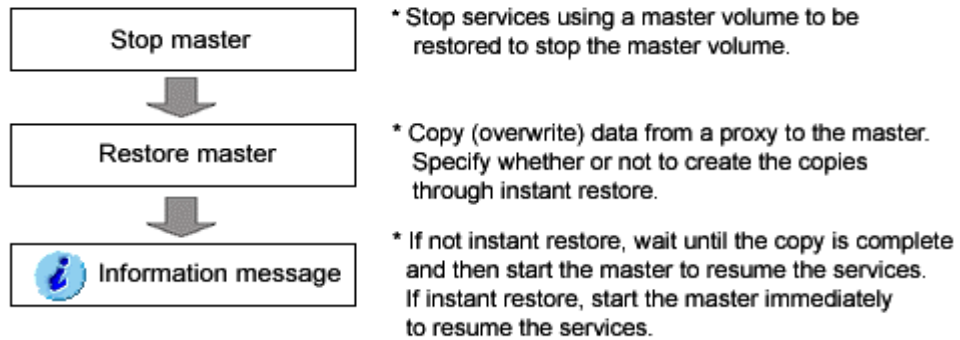

See

For details about the operation methods, see "5.3.3 Restore."

5.1.4 Disk Swap

The following operations are required for swapping disks in the even of a disk error, or for the purpose of preventive maintenance.

Chart: Disk Swap and Restoration Operation

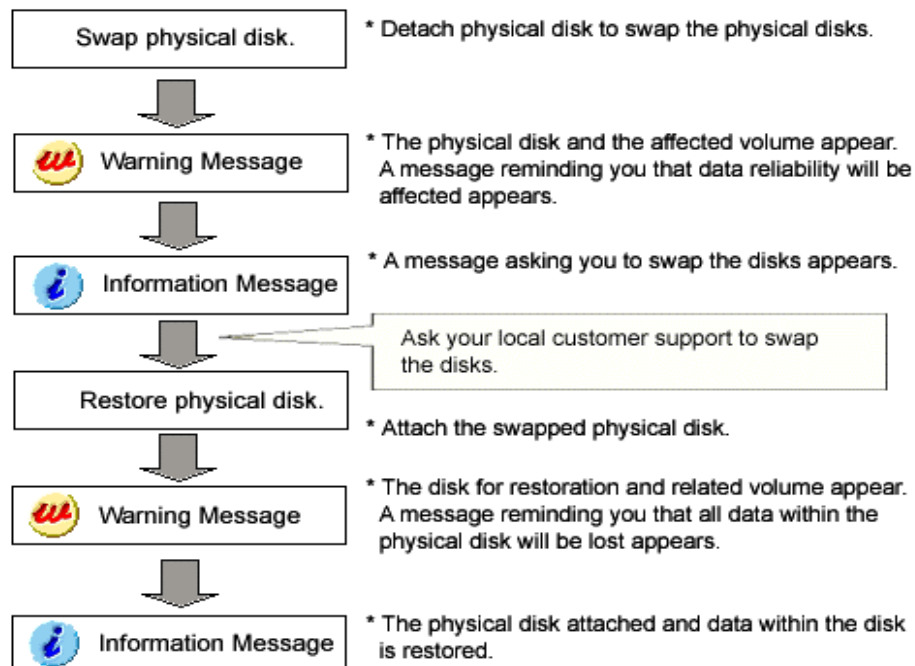

See

For details about the operation methods, see "5.3.4 Disk Swap."

5.1.5 Disk Migration

The following figure shows the procedures for migrating disks through use of GDS Snapshot proxy volumes.

Chart: Disk Migration Operation

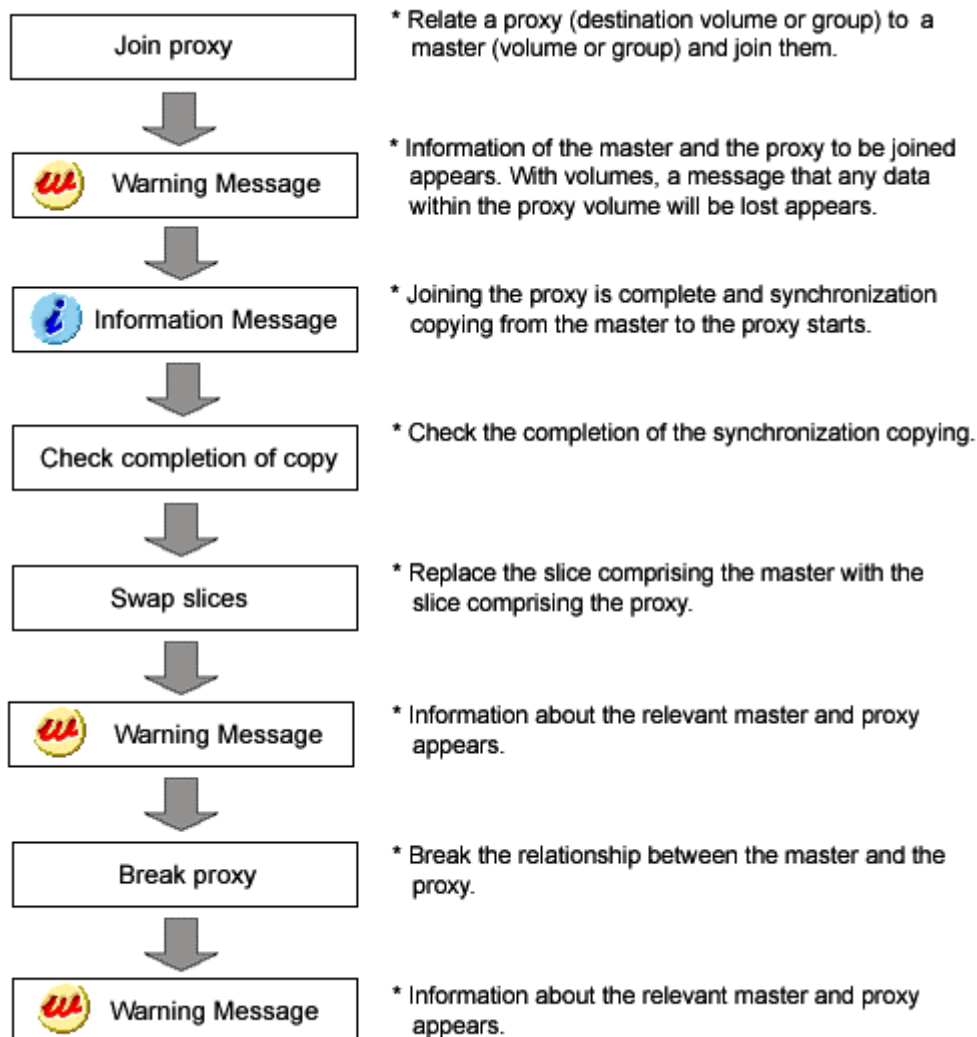

See

For details about the operation methods, see "5.3.5 Disk Migration."

5.1.6 Configuration Change

Procedures for changing or removing the configuration settings is shown below.

Chart: Configuration Changing Operation

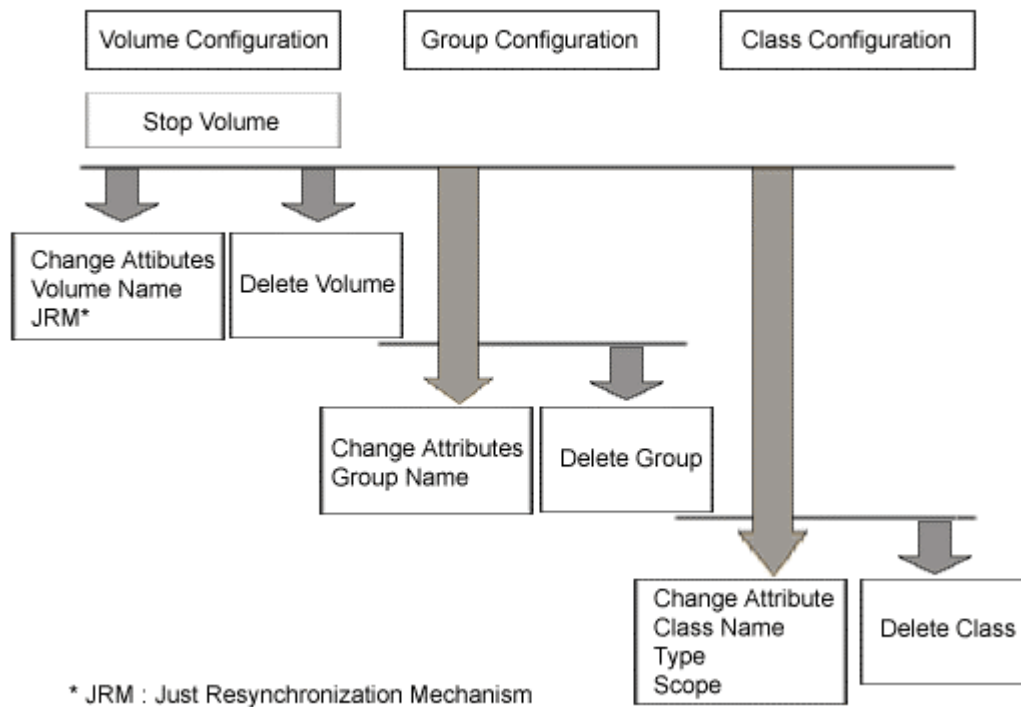

See

For details about the operation methods, see "5.4 Changes" or "5.5 Removals."

5.1.7 Operations from GDS Management View

GDS Management View supports the following operations.

Use commands for operations that are unsupported in GDS Management View.

Class operation

Operation	Command Operation	GDS Management View Operation
Create	# sdxdisk -M	For details, see "5.2.1.1 Class Configuration" in "5.2.1 Operating from the Settings Menu."
Remove	# sdxdisk -R or # sdxclass -R	For details, see "5.5.4 Removing a Class" in "5.5 Removals"
Change Attribute (Class Name)	# sdxattr -C -a name= <i>classname</i>	For details, see "5.4.1 Class Configuration" in "5.4 Changes."
Change Attribute (Scope)	# sdxattr -C -a scope= <i>node:node:...</i>	For details, see "5.4.1 Class Configuration" in "5.4 Changes."
Change Attribute (Hot Spare)	# sdxattr -C -a hs={on off}	Unsupported
Change Attribute (Hot Spare Mode)	# sdxattr -C -a hsmode={exbox bybox}	Unsupported
Restore	# sdxfix -V	Unsupported

Group operation

Operation	Command Operation	GDS Management View Operation
Connect	# sdxdisk -C or # sdxgroup -C	For details, see "5.2.1.2 Group Configuration" in "5.2.1 Operating from the Settings Menu."
Remove	# sdxdisk -D or # sdxgroup -D or # sdxgroup -R	For details, see "5.5.3 Removing a Group" in "5.5 Removals."
Change Attribute (Group Name)	# sdxattr -G -a name= <i>groupname</i>	For details, see "5.4.2 Group Configuration" in "5.4 Changes."
Change Attribute (Active Disk)	# sdxattr -G -a actdisk= <i>disk</i>	Unsupported

Volume operation

Operation	Command Operation	GDS Management View Operation
Create	# sdxvolume -M	For details, see "5.2.1.3 Volume Configuration" in "5.2.1 Operating from the Settings Menu."
Remove	# sdxvolume -R	For details, see "5.5.2 Removing a Volume" in "5.3.3 Removals."
Start	# sdxvolume -N	For details, see "Start Volume" in "4.2.3 Operation."
Stop	# sdxvolume -F	For details, see "Stop Volume" in "4.2.3 Operation."
Expand	# sdxvolume -S	Unsupported
Change Attribute (Volume Name)	# sdxattr -V -a name= <i>volume name</i>	For details, see "5.4.3 Volume Configuration" in "5.4 Changes."
Change Attribute (JRM)	# sdxattr -V -a jrm={on off}	For details, see "5.4.3 Volume Configuration" in "5.4 Changes."

Operation	Command Operation	GDS Management View Operation
Change Attribute (Physical Slice)	# sdxattr -V -a pslice=[on off]	For details, see "5.4.3 Volume Configuration" in "5.4 Changes."
Change Attribute (Lock Volume)	# sdxattr -V -a lock=[on off]	Unsupported
Change Attribute (Access Mode)	# sdxattr -V ... -a mode=[rw ro]	Unsupported
Change Attribute (JRM for Proxy)	# sdxattr -V -a pjrm= off	Unsupported
Start Copying	# sdxcopy -B	For details, see "5.3.6 Copying Operation" in "5.3 Operation in Use."
Cancel Copying	# sdxcopy -C	For details, see "5.3.6 Copying Operation" in "5.3 Operation in Use."
Restore	# sdxfix -V	Unsupported

Slice operation

Operation	Command Operation	GDS Management View Operation
Detach	# sdxslice -M	For details, see "5.3.2.1 Backup(by Slice Detachment)" in "5.3 Operation in Use."
Attach	# sdxslice -R	For details, see "5.3.2.1 Backup(by Slice Detachment)" in "5.3 Operation in Use."
Activate	# sdxslice -N	For details, see "5.3.2.1 Backup(by Slice Detachment)" in "5.3 Operation in Use."
Stop	# sdxslice -F	For details, see "5.3.2.1 Backup(by Slice Detachment)" in "5.3 Operation in Use."
Take over	# sdxslice -T	Unsupported
Change Attribute	# sdxattr -S	Unsupported

Disk operation

Operation	Command Operation	GDS Management View Operation
Swap	# sdxswap -O	For details, see "5.3.4 Disk Swap" in "5.3 Operation in Use."
Restore	# sdxswap -I	For details, see "5.3.4 Disk Swap" in "5.3 Operation in Use."
Change Attribute	# sdxattr -D	For details, see "5.4.1 Class Configuration" in "5.4 Changes."
Clear Errors	# sdxfix -D	Unsupported

Proxy operation

Operation	Command Operation	GDS Management View Operation
Join	# sdxproxy Join	For details, see "5.2.3.1 Join" in the "5.2 Settings."
Part	# sdxproxy Part	For details, see "5.3.2.2 Backup(by Synchronization)" in "5.3 Operation in Use."
Rejoin	# sdxproxy Rejoin	For details, see "5.3.2.2 Backup(by Synchronization)" in "5.3 Operation in Use."
Rejoin and Restore	# sdxproxy RejoinRestore	For details, see "5.3.3 Restore" in "5.3 Operation in Use."
Swap	# sdxproxy Swap	For details, see "5.3.5 Disk Migration" in "5.3 Operation in Use."
Relate	# sdxpsoxy Relate	For details, see "5.2.3.2 Relate" in "5.2 Settings."
Update	# sdxpsoxy Update	For details, see "5.3.2.3 Backup(by OPC)" in "5.3 Operation in Use."
Restore	# sdxpsoxy Restore	For details, see "5.3.3 Restore" in "5.3 Operation in Use."
Cancel Hard Copy Session	# sdxpsoxy Cancel	Unsupported
Break	# sdxproxy Break	For details, see "5.5.5 Breaking a Proxy" in the "5.5 Removals."

Shadow operation

Operation	Command Operation	GDS Management View Operation
Operate Shadow Disk	# sdxshadowdisk	Unsupported
Operate Shadow Group	# sdxshadowgroup	Unsupported
Operate Shadow Volume	# sdxshadowvolume	Unsupported

Other operations

Operation	Command Operation	GDS Management View Operation
Configuration Parameter Operations	# sdxparam	Unsupported

5.2 Settings

This section explains the GDS setting procedure.

5.2.1 Operating from the Settings Menu

From the main screen, click [XXXXX Configuration] in the [Settings] menu. Settings screen for different features appears. Use the screen switch tab to switch between "Class Configuration", "Group Configuration" and "Volume Configuration".



Note Configuring a System of High Reliability

In order to ensure a system of high reliability, mirroring disks connected to separate I/O adapter, controller and cable is recommended.

5.2.1.1 Class Configuration

In this section, how to create a new class is explained.

In the [Settings] menu, click [Class Configuration]. Class Configuration screen appears.

Figure: Class Configuration

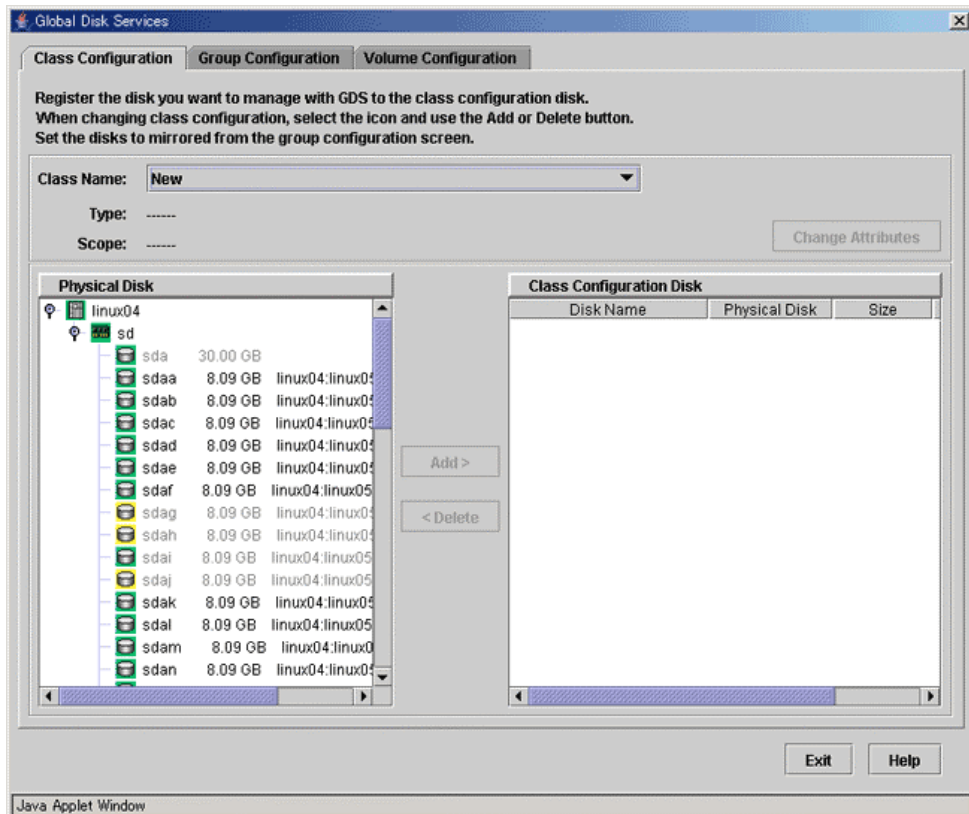

1. Selecting class name

In the "Class Name" list, select "New".

2. Selecting physical disk

In the <Physical Disk List>, select the physical disk you want to include in the disk class. You can select more than one physical disk at a time.

Selecting a physical disk will make the <Add> button available.

Figure: Selecting Physical Disk to Configure Class

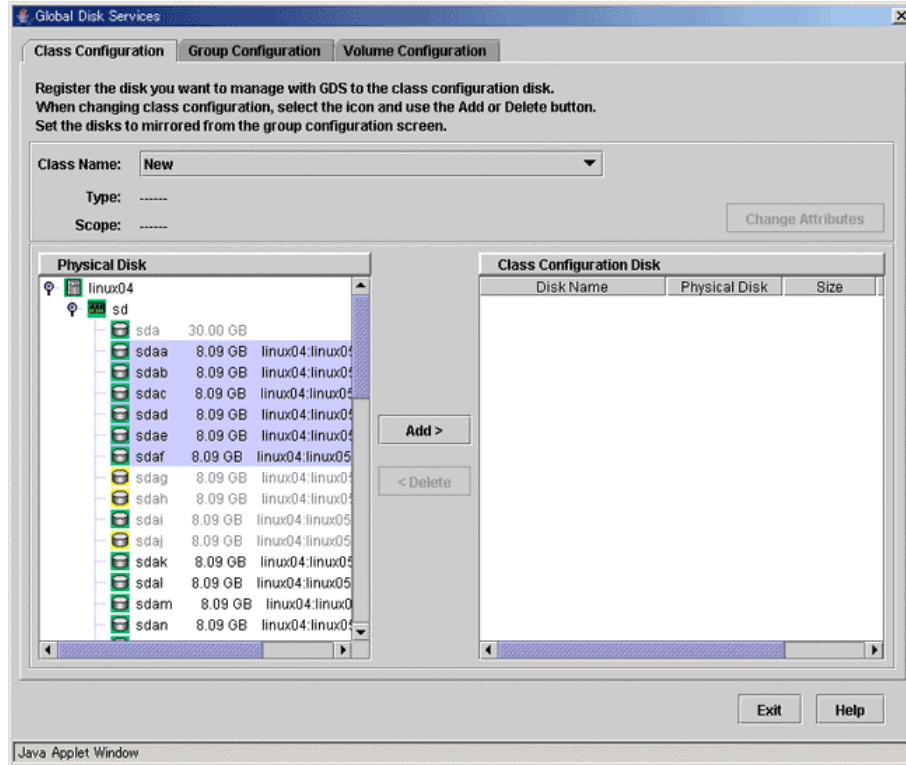

3. Creating a class

Press <Add>, and the message below appears.

Figure: Warning

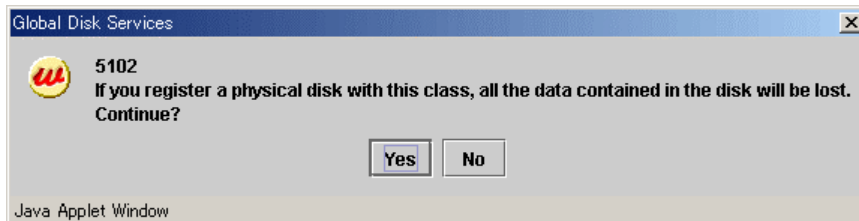

Press <Yes> to continue, and <No> to cancel.

Press <Yes>, and Class Attributes Definition screen appears.

Figure: Class Attributes Definition

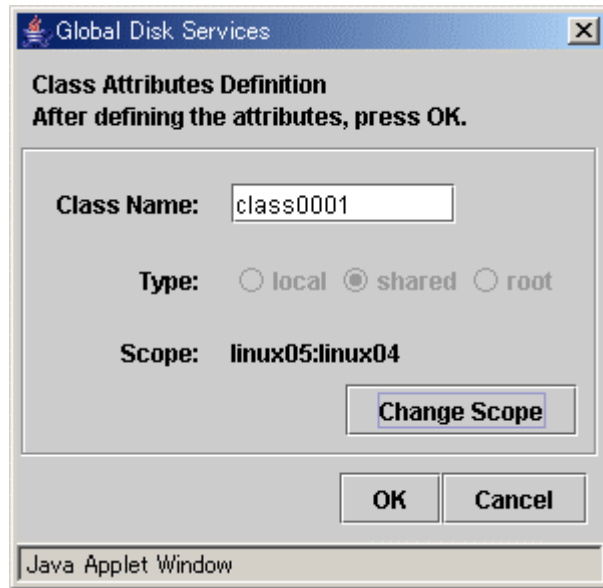

In the "Class Name" of Class Attributes Definition screen, an automatically created disk class name appears as default. Change the "Class Name" if necessary, and press <OK>.

The "Type" is "shared" and the "Scope" indicates a node that can share disks with respect to the class. To accept the settings, click the <OK> button.



Note Inputting Class Name

Class name will be used for the device path name.

/dev/sfdsk/class name/[r]dsk/volume name

You must be careful when inputting the class name, as once the volume is created, it cannot be changed.



See

For information on assigning a class name, see "A.1.1 Object Name."

To change the scope, click the <Change Scope> button.

After clicking the <Change Scope> button, the [Change Scope] dialog box appears.

Figure: Change Scope

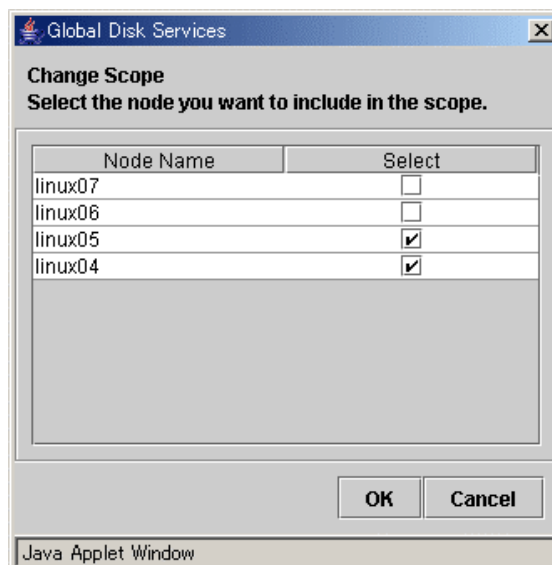

- Specify one or more nodes by checking or unchecking the boxes on the [Change Scope] dialog box.
- Click the <OK> button on the [Change Scope] dialog box to accept the changes of nodes that can share the class.
- The <Cancel> button on the [Change Scope] dialog box can cancel changing scope.

This operation determines the class name.

If you press <Cancel> in the Class Attributes Definition screen, registration of the physical disk itself will be canceled.

4. Setting disk attributes

Selecting the "Disk Name" in the [Class Configuration Disk] field allows you to set the disk attributes. From here, you can change the "Disk Name" and "Type".

- a) Changing disk name
Double-click the "Disk Name" in the [Class Configuration Disk] field, and change the name.
- b) Changing disk type
Display the "Disk Type" in the [Class Configuration Disk] field and select the disk type you wish to change from the list. When specifying as a spare disk select "spare." When specifying as a single disk, select "single." Default is set to "undef."

5. Completing class creation

After creating all classes, press <Exit> and close Class Configuration screen.



Note **Class Resources**

- Class resources are added through class creation and removed through class removal.
- To remove class resources, remove the corresponding classes without using PRIMECLUSTER commands.
- Configure cluster applications that use class resources only after volume configuration is complete.



See

For the cluster system installation and initial setting procedures, see "PRIMECLUSTER Cluster Foundation Configuration and Administration Guide."

5.2.1.2 Group Configuration

In this section, how to create a new group is explained.
In the [Settings] menu, click [Group Configuration]. Group Configuration screen appears.

Figure: Group Configuration

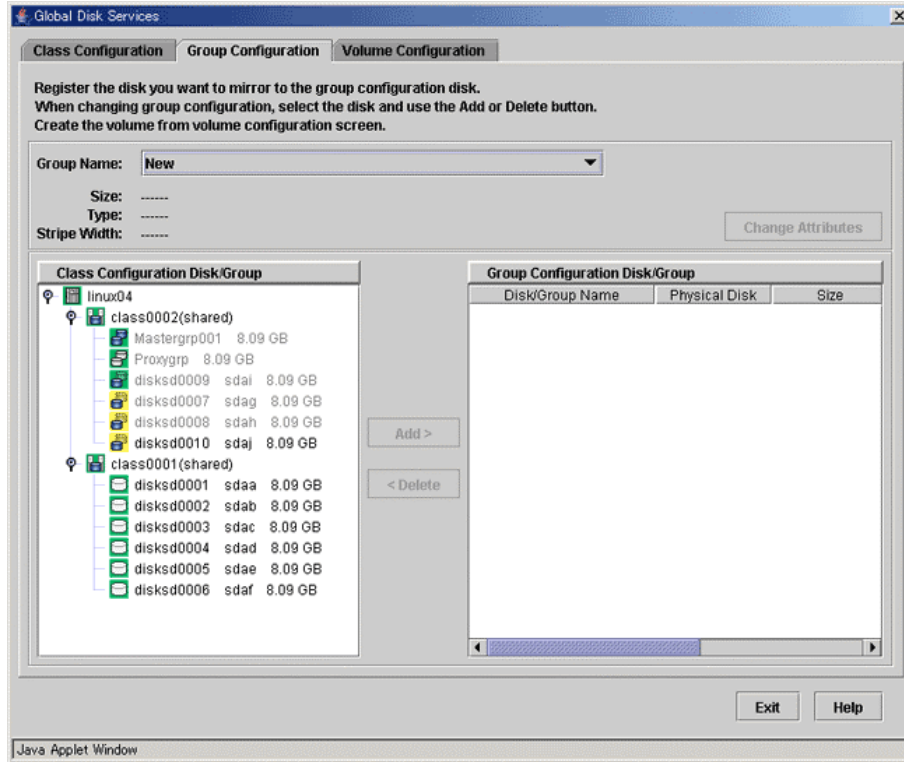

Follow the procedures below to create a new group.

1. Selecting group name

In the "Group Name" list, select "New."

2. Selecting disk/lower level group

In the [Class Configuration Disk/Group] list, select the disk/lower level group you want to include in the disk group.

You can select more than one disk/group at a time.

Selecting a disk/group will make the <Add> button available.

Figure: Selecting Disk/Lower level group to Configure Group

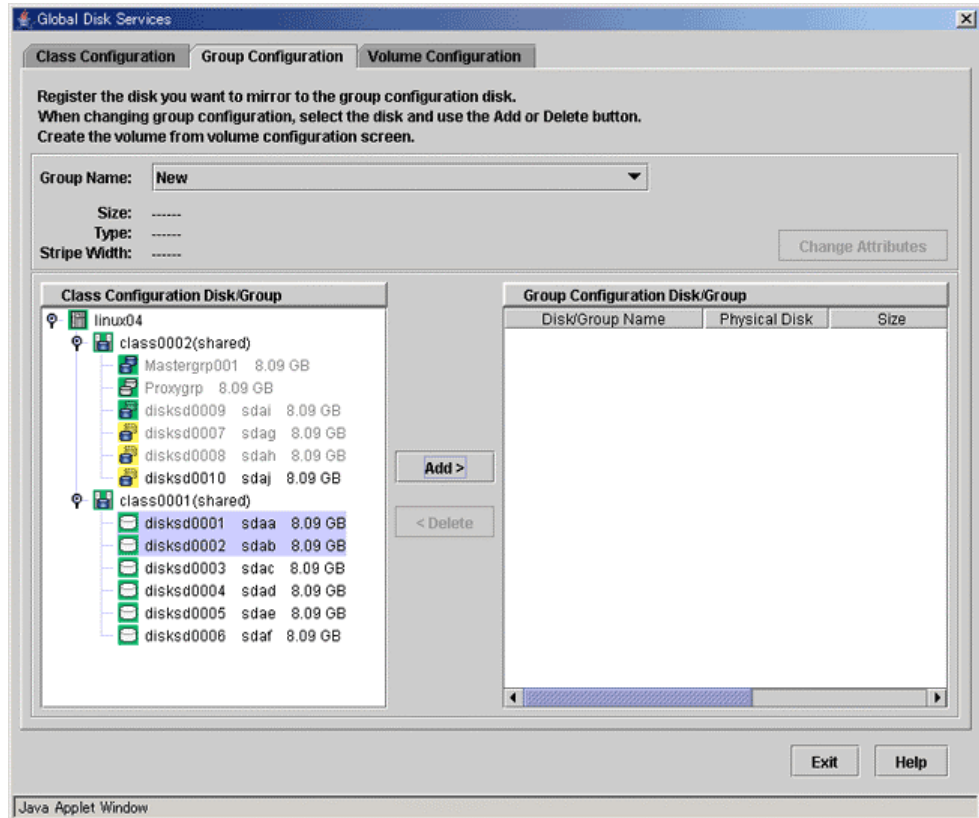

3. Creating a group

Press <Add>, and the [Group Attributes Definition] screen appears. You will be able to specify the group attributes such as group name, type and stripe width.

Figure: Group Attributes Definition Screen



- a) Setting "Group Name"
Enter the group name.
Change the default group name if necessary.

- b) Setting "Type"
Set the group type.
Select "mirror" for mirroring, "stripe" for striping, and "concat" for concatenating. The default setting is "mirror".

- c) Setting "Stripe Width"
You will be able to enter this field only when you select "stripe" for the "Type." For the stripe width, you can specify a value of two raised to the power.
The default setting is "32".

After setting the attributes, press <Exit> and a new group will be created.
If you press <Cancel> in the [Group Attributes Definition] screen, connection of the disk itself will be canceled.



See

For information on assigning a group name, see "A.1.1 Object Name."

4. Completing group creation

After creating all groups, press <Exit> and close [Group Configuration] screen.

5.2.1.3 Volume Configuration

In this section, how to create a new volume is explained.
In the [Settings] menu, select [Volume Configuration]. The Volume Configuration screen appears.

Figure: Volume Configuration

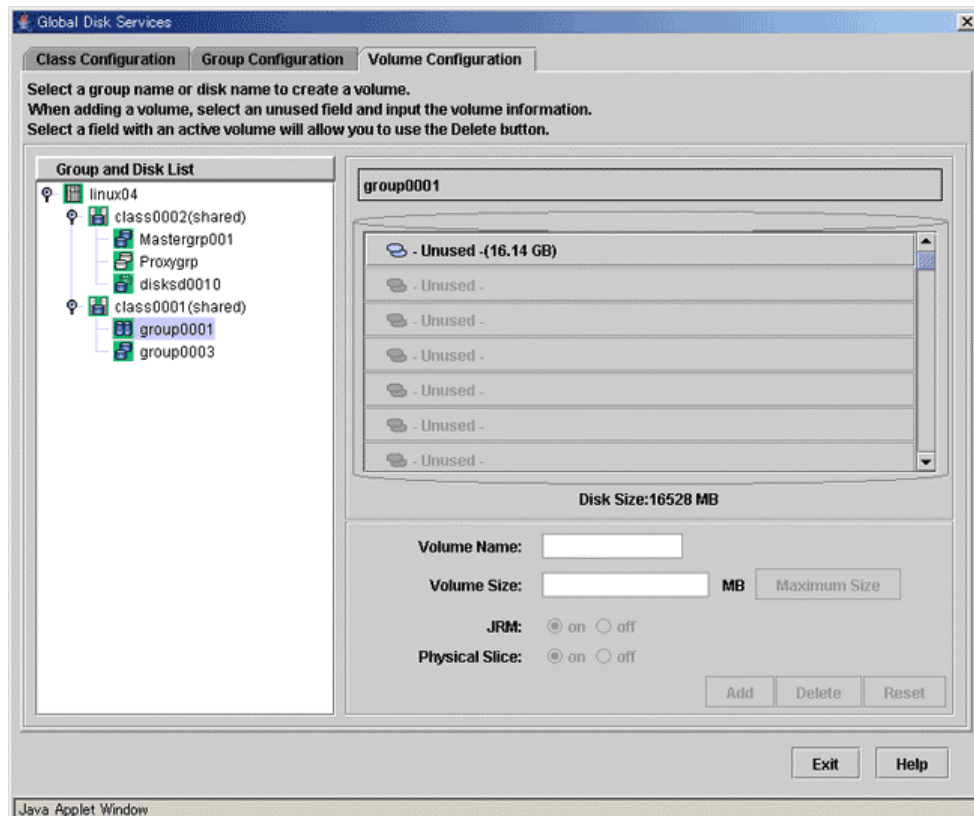

Follow the procedures below to create a volume.

1. Selecting group/disk

In the [Group and Disk List], select the group or the disk.

2. Selecting unused volume

Click <Unused> with a volume icon, and select an unused volume.

3. Setting volume attributes

Selecting an unused volume will allow you to type in the volume attributes field (Volume Name, Volume Size, JRM, Physical Slice).

a) Setting "Volume Name"

Type the volume name.



[See](#)

For information on assigning a volume name, see "A.1.1 Object Name."

b) Setting "Volume Size"

Type the volume size in MB units, using numbers only.



Note Size and Cylinder Boundary

When the specified size does not match the cylinder boundary, it will automatically adjust by rounding up. For details, see "A.2.6 Volume Size."

c) <Maximum Size> button

Sets the value in the "Volume Size" field to the maximum available size.

d) Setting "JRM"

Default is set to "on." Change the setting when you want to disable the just resynchronization copying feature.

When you select a stripe group or concatenation group in step 1, the setting will fail.

e) Setting "Physical Slice"

Sets the volume's physical slice attribute value.

on : a volume which consists of physical slices is created.

off: a volume without physical slices is created.

When you select a stripe group or concatenation group in step 1, the setting will fail.

Figure: Setting Volume Attributes

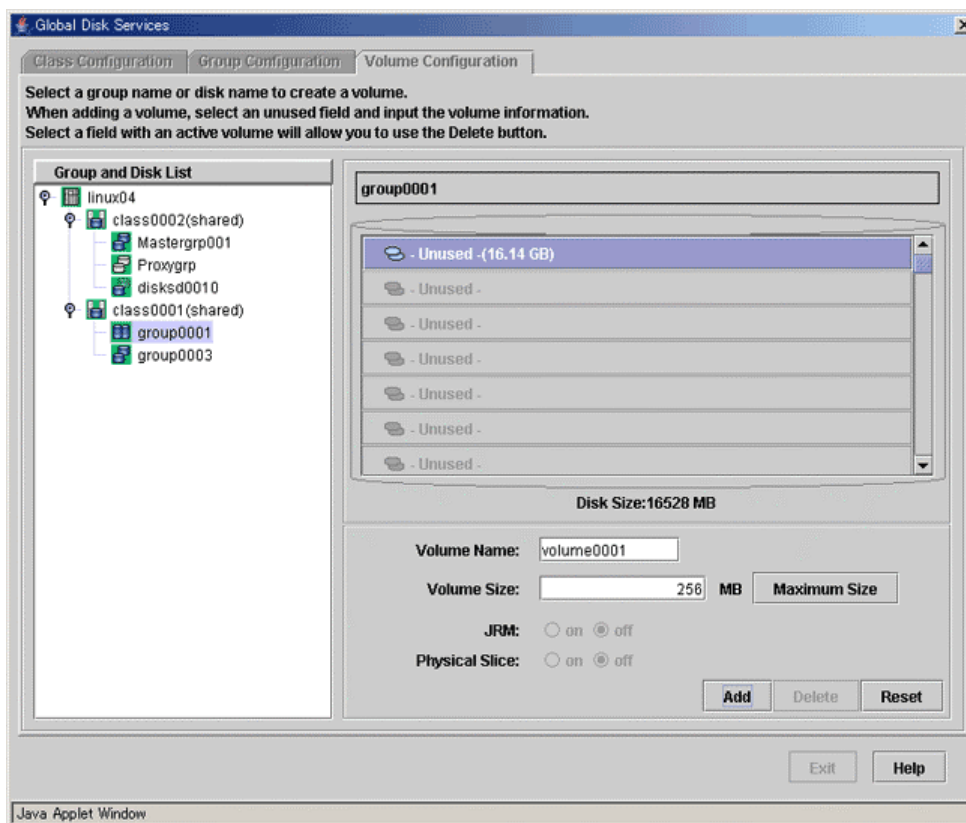

4. Determining the new volume

After setting the attributes, click <Add>. A new volume will be created.

If you click <Reset>, creation of the new volume will be canceled.

After creating all volumes, click <Exit> and close Volume Configuration screen.

After creating the volume, the volume will be started. You can access to the volume using the following special files.

/dev/sfdsk/class name/rdsk/volume name

/dev/sfdsk/class name/dsk/volume name



Note Shared Class Volume Operation

Volume created in a shared class cannot be used from other nodes immediately. If you wish to access from other nodes, you must activate the volume from the node you wish to access. After activating the volume, the node which created the volume, and the node which activated the volume will gain access. However, since operating from two nodes could affect data consistency, you must be careful when operating the volume.

5.2.2 File System Configuration

In this section, how to create a file system in a volume is explained.
In the [Settings] menu, click [File System Configuration].
File System Configuration screen appears.

Figure: File System Configuration

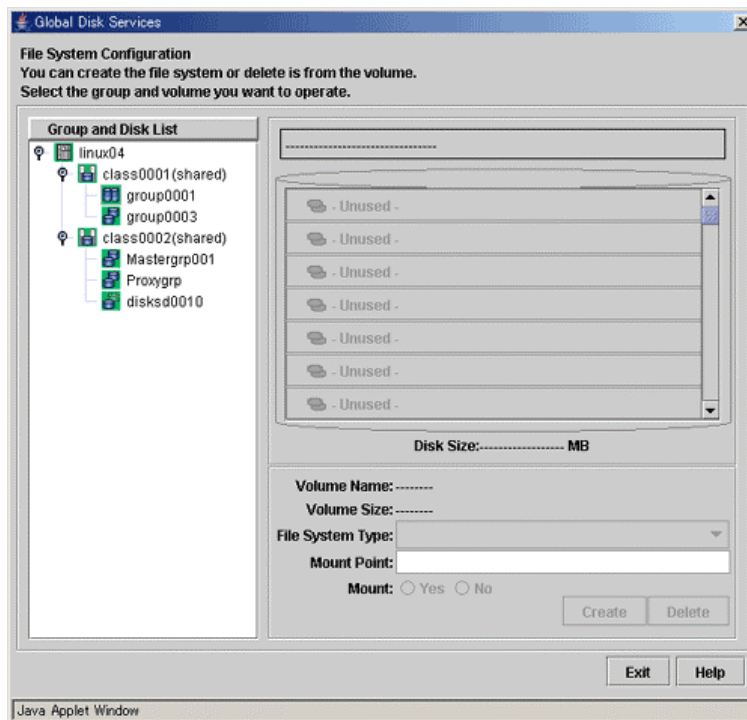

1. **Selecting a group/disk**
In the Group/Disk List, select a group or disk with which you want to perform an operation.
2. **Selecting a volume**
Select a volume in which you want to create a file system.
3. **Setting file system attributes**
Selecting a volume will allow you to type in the file system attributes field (File System Type, Mount Point, Mount).

Figure: Setting File System Attributes

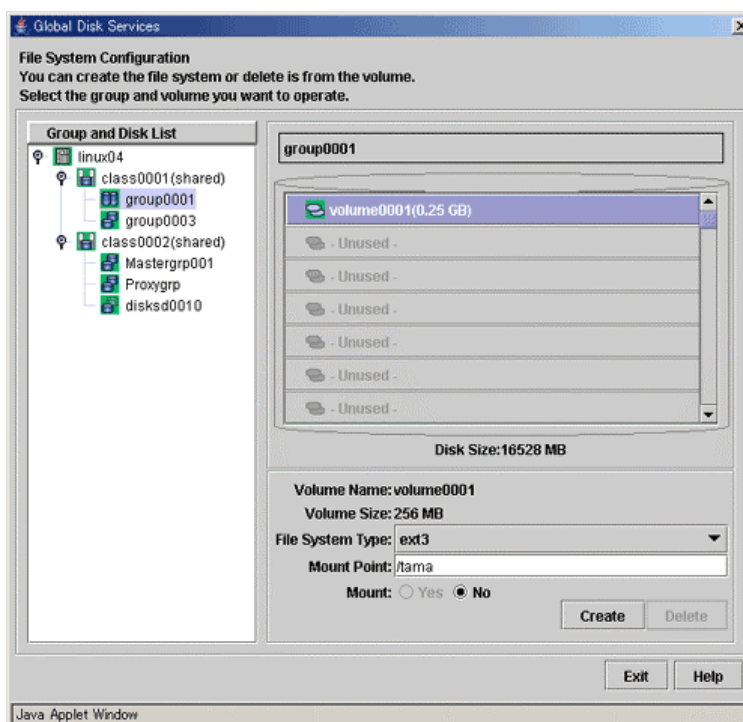

- a) Setting "File System Type"
Select the file system type.
 - b) Setting "Mount Point"
Type the mount point you want to set for /etc/fstab.
 - c) Setting "Mount"
Once file systems are created in step 4, mount information is added to the /etc/fstab file and "no" is specified in the "mount at boot" field. Edit the mount information in the /etc/fstab file as needed after step 4 is complete.
4. **Creating the file system**
After setting the attributes, press <Create>. A new file system will be created.
After creating all file systems, press <Exit>.



Note When Using Cluster System

When using a volume of a shared disk as a file system in a cluster system, certain settings are required after creating the file system. For details about how to set the file system created on a shared disk, see "PRIMECLUSTER Reliant Monitor Services (RMS) Configuration and Administration Guide."

5.2.3 Proxy Configuration

This section describes the procedures for relating proxy objects (proxy volumes or groups) to master objects (volumes or groups) in a system on which GDS Snapshot is installed.

The following two methods are available.

- **Join**
Relate a proxy to a master and join them. Synchronization copying from the master to the proxy is launched, and after the copying is complete, they are synchronized. When joining groups, proxy volumes are created in the proxy group and they are joined to their corresponding master volumes.
- **Relate**
Relate a proxy to a master and leave them parted. The statuses and contents of the master and the proxy remain unchanged.

5.2.3.1 Join

This subsection describes procedures for joining proxy volumes or proxy groups to volumes or groups in GDS Snapshot installed systems.

1. Selecting a master volume or a master group

Click an icon of a volume or a group to which a proxy is joined in the Main Screen.

2. Selecting the [Join] menu

Select [Operation]:[Proxy Operation]:[Join] in the Main Screen.

Figure: Join

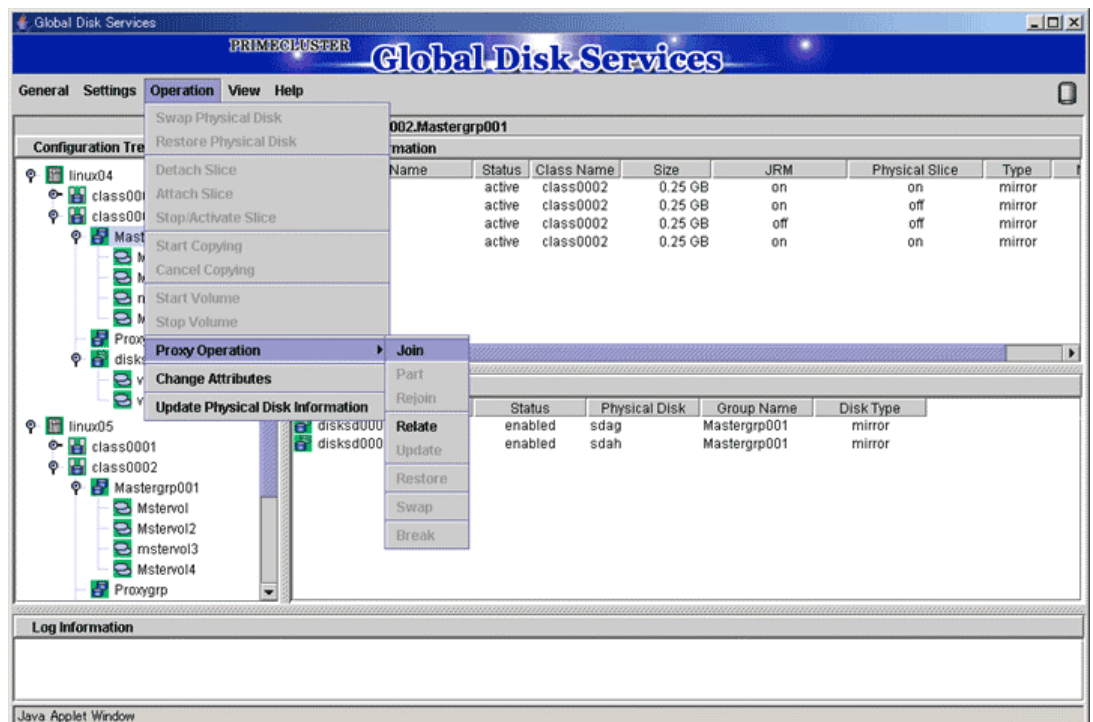

3. Selecting a proxy to be joined

The Select Proxy dialog box appears.



Information

The following figure shows the window for group connection.

On the window for volume connection, the <OK> button appears in the position of the <Next> button.

Figure: Select Proxy

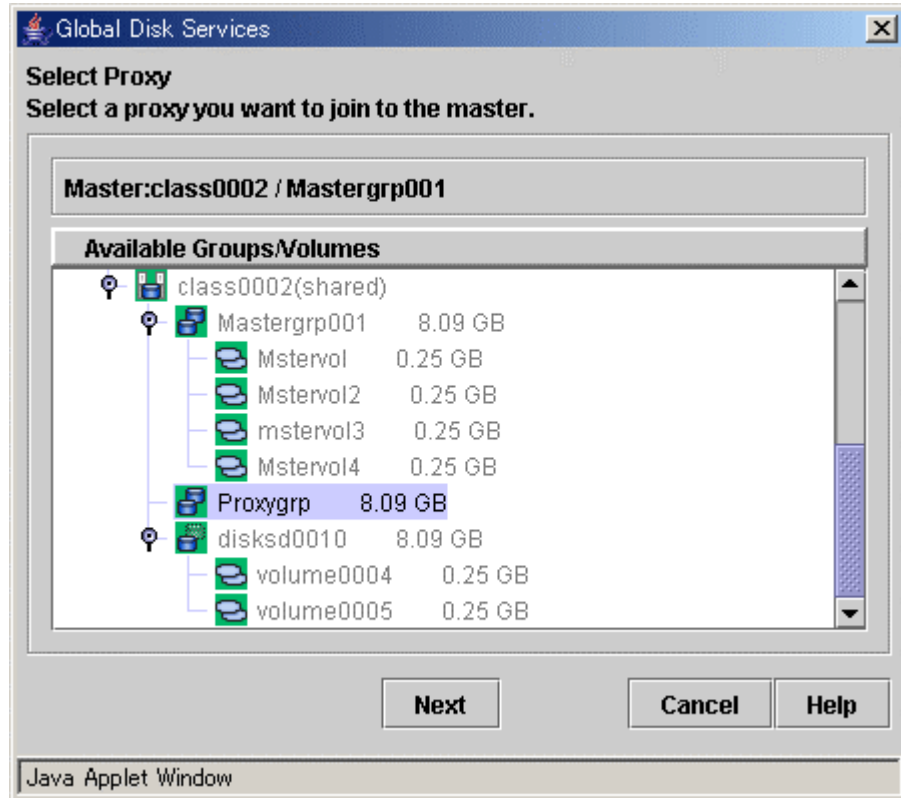

Select a volume or a group to be joined to the master volume or the master group from the [Available Groups/Volumes] list.

Volumes or groups conforming to all of the following conditions are selectable.

object	Volume	Group
conditions	<ul style="list-style-type: none"> • Belongs to the class of the master volume • Equal to the master volume in size • Mirror type or single type (Volumes created in hierarchized mirror groups are also selectable. Any mirroring multiplicity is supported.) • Does not belong to the group or single disk of the master volume • Is not related to other master objects or proxy objects 	<ul style="list-style-type: none"> • Belongs to the class of the master group • Mirror type (Hierarchized mirror groups are also selectable. Any mirroring multiplicity is supported.) • Includes no volume • Is not related to other master objects or proxy objects



Note Status of Proxy Volumes That Can Be Joined

"Active" proxy volumes cannot be joined. To join an "active" proxy volume, stop the proxy volume in advance.

When joining volumes, select a volume to be joined to the master volume and click <OK>. When joining groups, select a group to be joined to the master group and click <Next>. Clicking <Cancel> cancels the join process.

4. Defining attributes of proxy volumes created in the proxy group

When joining groups, the Volume Attributes Definition dialog box appears.

Figure: Proxy Volume Attributes Definition

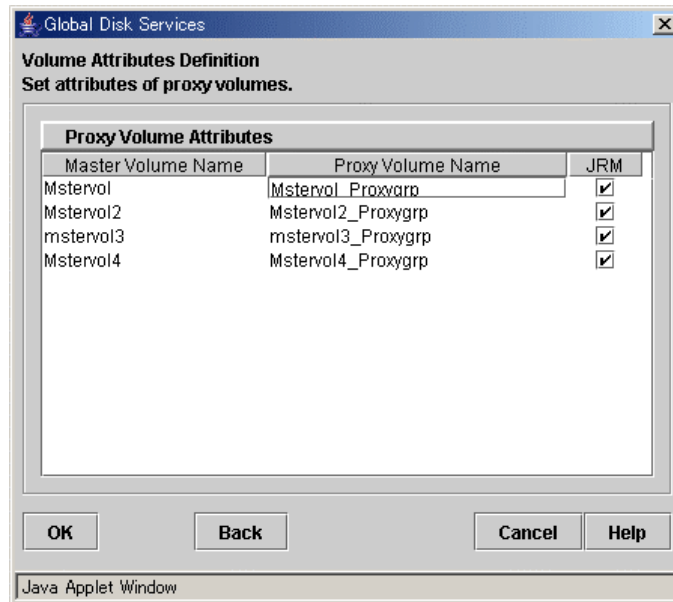

When a proxy group is joined to a master group, proxy volumes are created within the proxy group and joined to corresponding master volumes within the master group. In the Volume Attributes Definition dialog box, set attributes of such proxy volumes.

a) Proxy Volume Name

Assign volume names of proxy volumes. [Proxy Volume Name] shows default volume names. To change the default value, click and edit the volume name.



See

For the volume naming conventions, see "A.1.1 Object Name."



Information Automatically Generated Proxy Volume Names

Proxy volume names are automatically generated as "master volume name" + "_ (underscore)" + "proxy group name(for example, volume0001_group0002)".

b) JRM

Set JRM (Just Resynchronization Mechanism) for volumes. The default value is "on". To turn "off", uncheck the [JRM] box.



Information JRM for Volumes

The JRM setting in the Proxy Volume Attributes Definition dialog box is the "JRM for Volumes" of the proxy volume. Note that it is not the "JRM for Proxies". For details, see "A.2.10 Just Resynchronization Mechanism (JRM)."

When the settings are complete, click <OK>. Clicking <Cancel> cancels the join process.

5. Confirming

A confirmation dialog box appears asking you whether to join the proxy.

Figure: Confirming "Join" (Volumes)

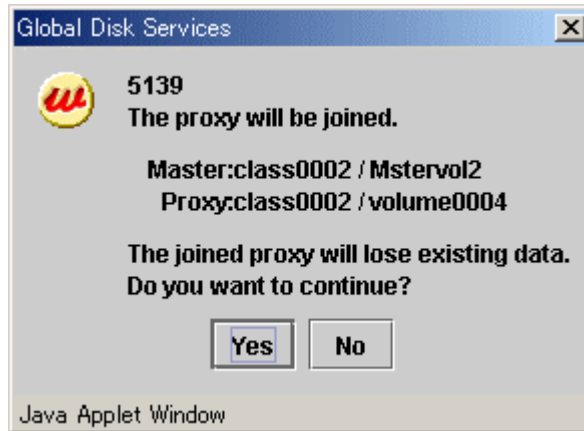

To continue the process, click <Yes>. Clicking <No> displays the Select Proxy dialog box shown in step 3 again.

Figure: Confirming "Join" (Groups)



To continue the process, click <Yes>. Clicking <No> displays the Volume Attributes Definition dialog box shown in step 4 again.

6. Information message of the completion

A message window appears informing you that the join process is complete.

Figure: Information Message of "Join" Completion

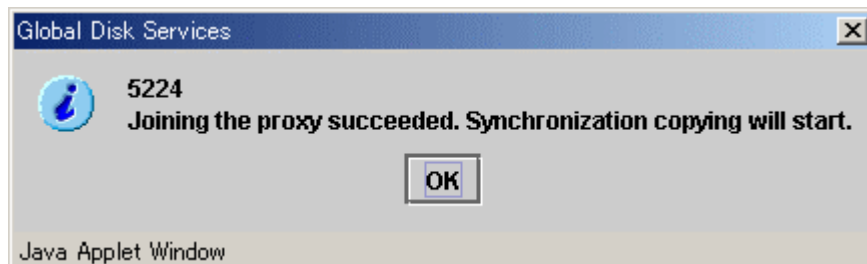

Click <OK> to close the information message window.

5.2.3.2 Relate

This subsection describes the procedures for relating proxy volumes or proxy groups to volumes or groups in GDS Snapshot installed systems.



Information Data of Related Masters and Proxies

Even if masters and proxies are related, data of the master objects and the proxy objects remain unchanged.

1. Selecting a master volume or a master group

Click the icon of a volume or a group to which a proxy is related in the Main Screen.

2. Selecting the [Relate] menu

Select [Operation]:[Proxy Operation]:[Relate] in the Main Screen.

Figure: Relate

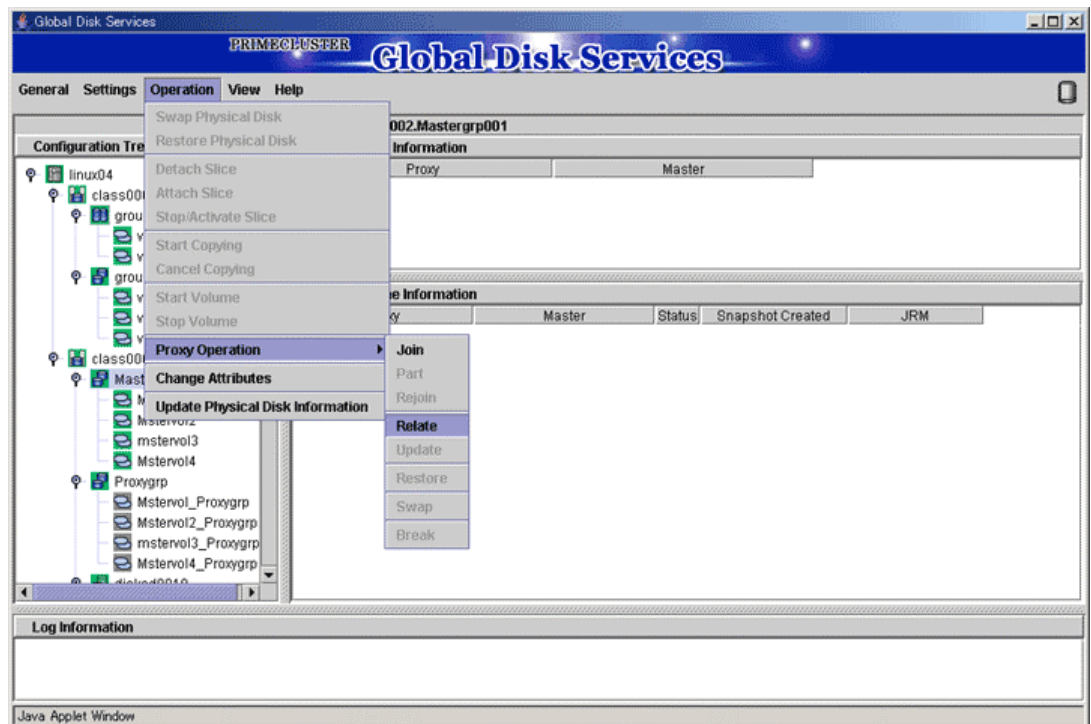

3. Selecting a proxy to be related

The Select Proxy dialog box appears.

Figure: Select Proxy

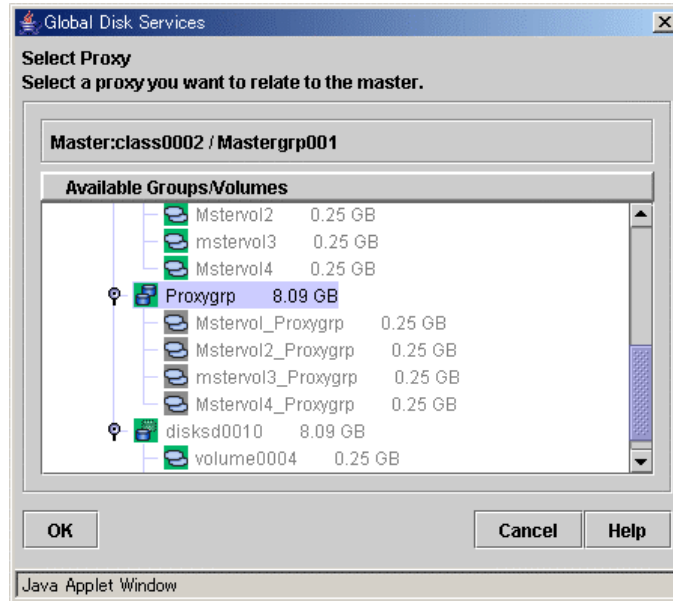

Select a volume or a group to be related to the master volume or the master group from the [Available Groups/Volumes] list.

Volumes or groups conforming to all of the following conditions are selectable.

object	Volume	Group
conditions	<ul style="list-style-type: none"> • Belongs to the class of the master volume • Equal to the master volume in size • Mirror type or single type (Volumes created in hierarchized mirror groups are also selectable. Any mirroring multiplicity is supported.) • Does not belong to the group or single disk of the master volume • Is not related to other master objects or proxy objects 	<ul style="list-style-type: none"> • Belongs to the class of the master group • Mirror type (Hierarchized mirror groups are also selectable. Any mirroring multiplicity is supported.) • Volume layout (offset and size) is same as that of the master group • Is not related to other master objects or proxy objects

Select a volume or a group to be related to the master volume or the master group and click <OK>. Clicking <Cancel> cancels the relating process.

4. Confirming

A confirmation dialog box appears asking you whether to relate the proxy.

Figure: Confirming "Relate"



To continue the process, click <Yes>. Clicking <No> displays the Select Proxy dialog box shown in step 3 again.

5. Information message of the completion

A message window appears informing you that the relating process is complete.

Figure: Information Message of "Relate" Completion

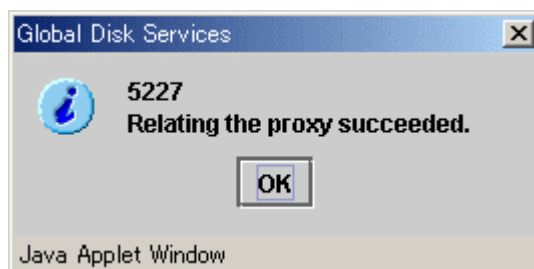

Click <OK> to close the information message window.

5.3 Operation in Use

GDS operates monitoring and maintenance from the main screen. This section explains the following operations:

- confirming configuration and monitoring status
- backup
- restore
- swapping disks
- copying operations
- migrating disks

5.3.1 Viewing Configurations and Monitoring Statuses

In the Main Screen, you can view configurations and monitor statuses of objects.

5.3.1.1 Confirming SDX Object Configuration

Select [SDX Object] in the [View]: [Details] menu to view object configurations according to the following units.

- Object configuration within a node
- Object configuration within a class
- Object configuration within a group
- Object configuration within a single disk
- Object configuration within a volume

For GDS Snapshot shadow objects, the object names, the status and so on are displayed in italics.

Object configuration within a node

Click the node icon in the Configuration Tree field, and all volumes and disks within the specified node appear.

Figure: Main Screen (for SDX Objects of a Node)

The screenshot displays the Global Disk Services (GDS) interface for a node named 'linux04'. The interface is divided into several sections:

- Configuration Tree:** A tree view on the left showing the hierarchy of objects under 'linux04', including classes, groups, and volumes.
- Volume Information:** A table listing volumes and their configurations.
- Disk Information:** A table listing disks and their configurations.
- Log Information:** A section at the bottom for viewing logs.

Volume Name	Status	Class Name	Size	JRM	Physical Slice	Type	Master
volume0001	active	class0001	0.25 GB	off	off	stripe	-----
volume0002	active	class0001	0.25 GB	on	on	mirror	-----
volume0003	active	class0001	0.51 GB	on	on	mirror	-----
Mstervol	active	class0002	0.25 GB	on	on	mirror	-----
Mstervol2	active	class0002	0.25 GB	on	off	mirror	-----
mstervol3	active	class0002	0.25 GB	off	off	mirror	-----
Mstervol4	stop	class0002	0.25 GB	on	on	mirror	-----
Mstervol_Proxygrp	stop	class0002	0.25 GB	on	on	mirror	-----
Mstervol2_Proxyg...	stop	class0002	0.25 GB	on	off	mirror	-----
mstervol3_Proxy...	stop	class0002	0.25 GB	on	off	mirror	-----

Disk Name	Status	Physical Disk	Group Name	Disk Type
disksd0001	enabled	sdaa	group0001	stripe
disksd0002	enabled	sdab	group0001	stripe
disksd0003	enabled	sdac	group0002	concat
disksd0004	enabled	sdad	group0002	concat
disksd0005	enabled	sdad	group0003	mirror
disksd0006	enabled	sdaf	group0003	mirror
disksd0007	enabled	sdag	Mastergrp001	mirror
disksd0010	enabled	sdah	Mastergrp001	mirror
disksd0009	enabled	sdai	Proxygrp	mirror
disksd0010	enabled	sdaj	-----	single

Object configuration within a class

Click the class icon in the Configuration Tree field, and all volumes and disks within the class appear.

Figure: Main Screen (for SDX Objects of a Class)

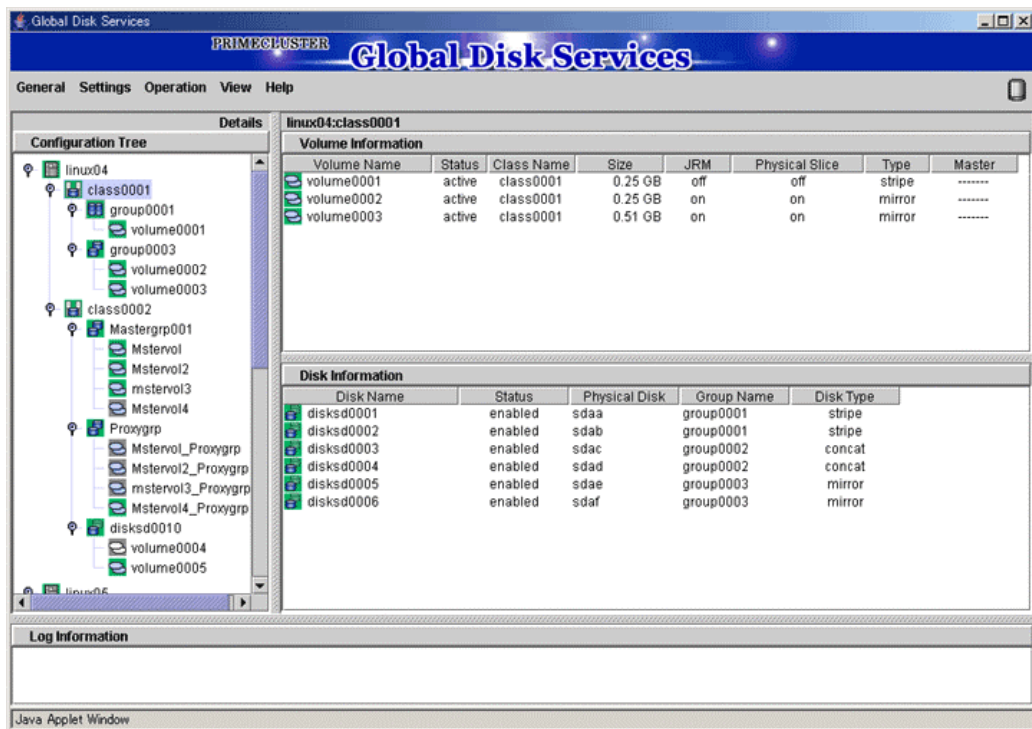

Object configuration within a group

Click a group icon in the GDS configuration tree field, and all volumes and disks at any level within the specified group appear. Additionally, place a mouse pointer on a group icon, and the disks and lower level groups constituting the group appear.

Figure: Main Screen (for SDX Objects of a Group)

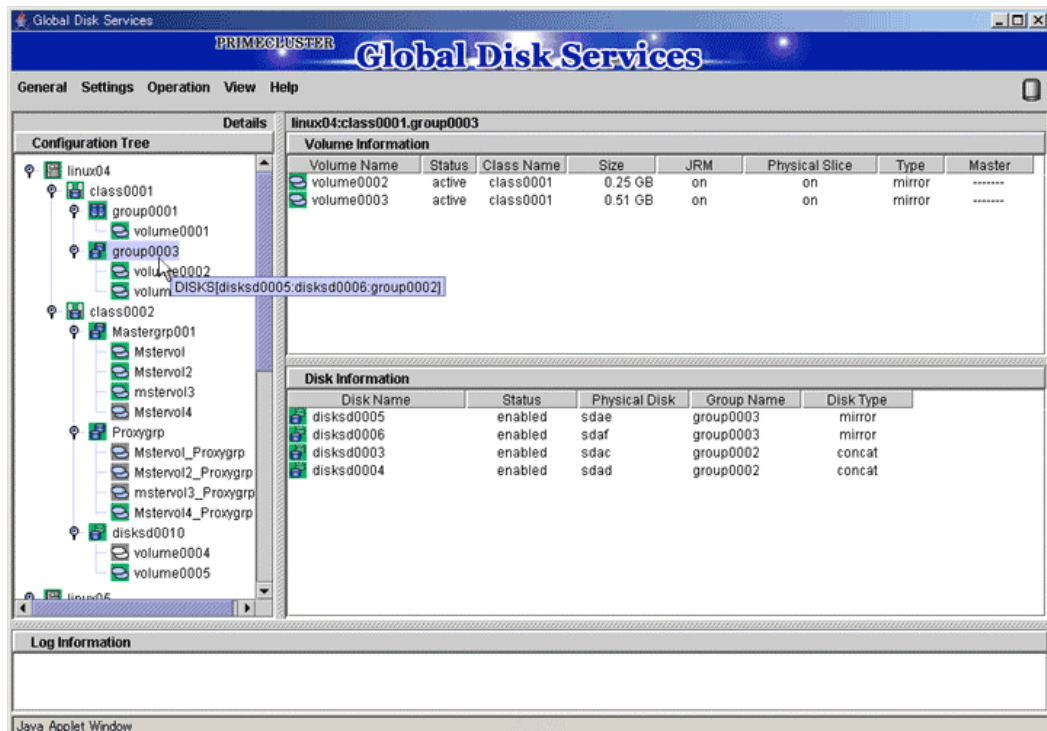

Groups displayed in the GDS configuration tree field are only the highest level groups. You can view the disks and lower level groups constituting their lower level groups in the group configuration screen.

Perform the following procedure.

1. Display the group configuration screen.
Click [Group Configuration] in the [Settings] menu on the main screen, and the group configuration screen will appear.
2. Select the group you want to view the configuration in the "Group Name" list.
3. In the [Group Configuration Group/Disk] field, view the disks and lower level groups constituting the group.

In this example, group group0003 has disk disksd0005, disksd0006 and lower level group group0002. In a similar manner, view the configuration of lower group group0002.

Figure: Confirming Group Configuration Group/Disk

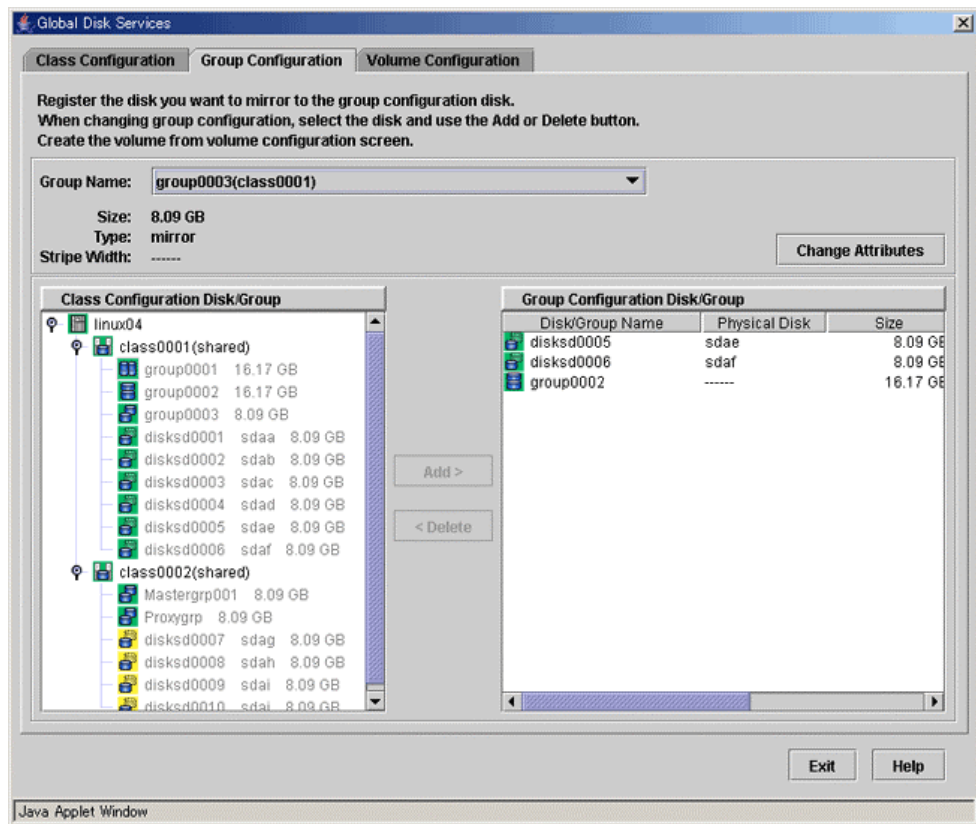

Object configuration within a single disk

Click a single disk icon in the GDS Configuration Tree Field to view all the volumes within the single disk as well as the single disk.

Figure: Main Screen (for SDX Objects of a Single Disk)

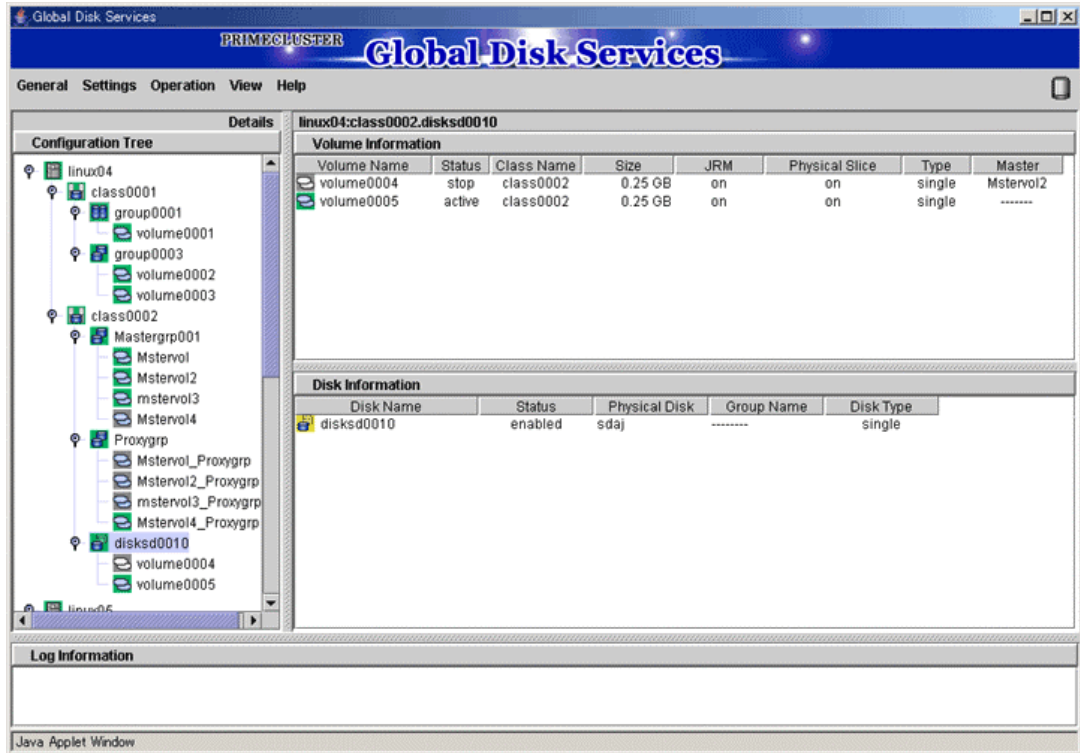

Object configuration within a volume

Click the volume icon in the Configuration Tree field, and all slices and disks within the specified volume appear.

Figure: Main Screen (for SDX Objects of a Volume)

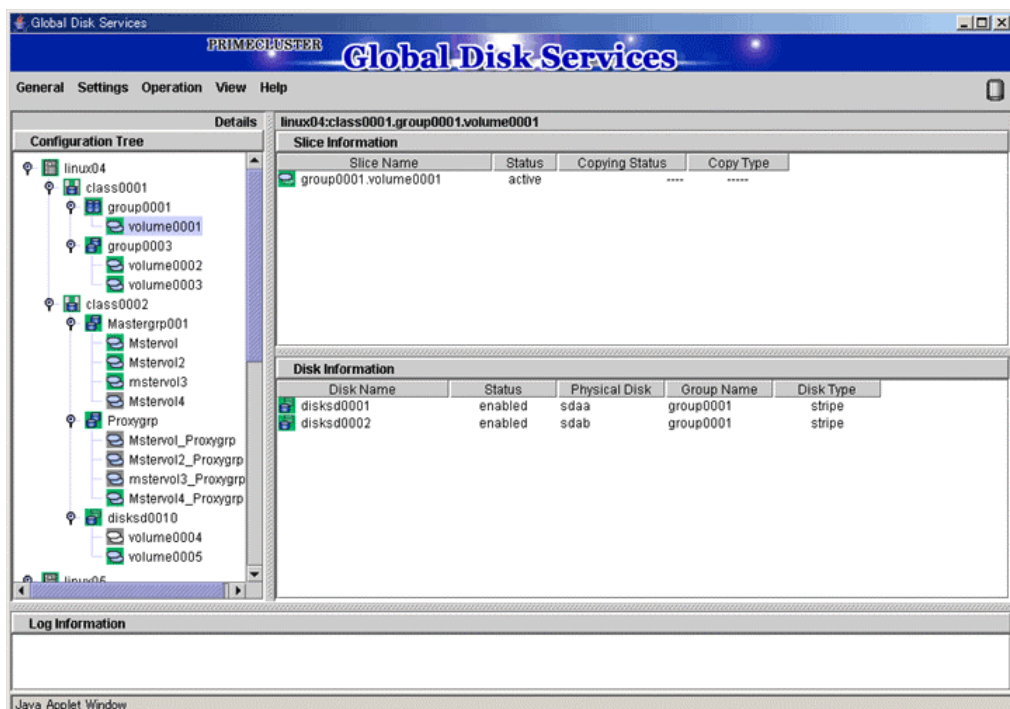

5.3.1.2 Viewing Proxy Object Configurations

Select [Proxy Object] in the [View]: [Details] menu to view object configurations according to the following units.

- Proxy object configuration within a node
- Proxy object configuration within a class
- Proxy object configuration related to a group
- Proxy object configuration within a single disk
- Proxy object configuration related to a volume

Proxy object configuration within a node

Click the node icon in the Configuration Tree field, and all proxy groups and proxy volumes within the specified node appear.

Figure: Main Screen (for Proxy Objects of a Node)

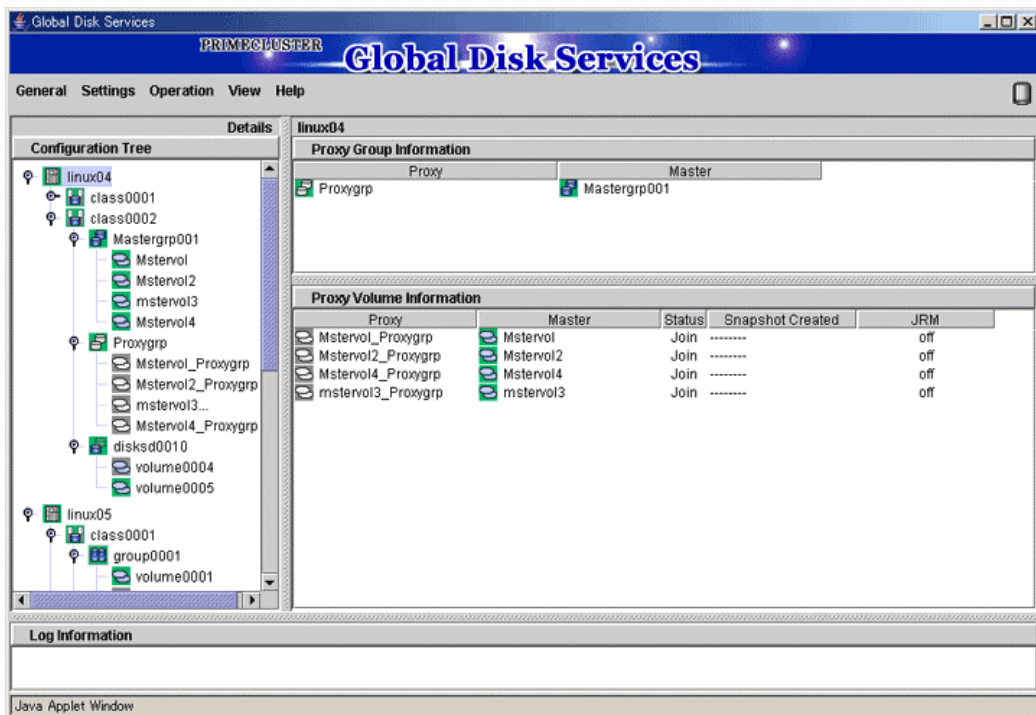

Proxy object configuration within a class

Click the class icon in the Configuration Tree field, and all proxy groups and proxy volumes within the class appear.

Figure: Main Screen (for Proxy Objects of a Class)

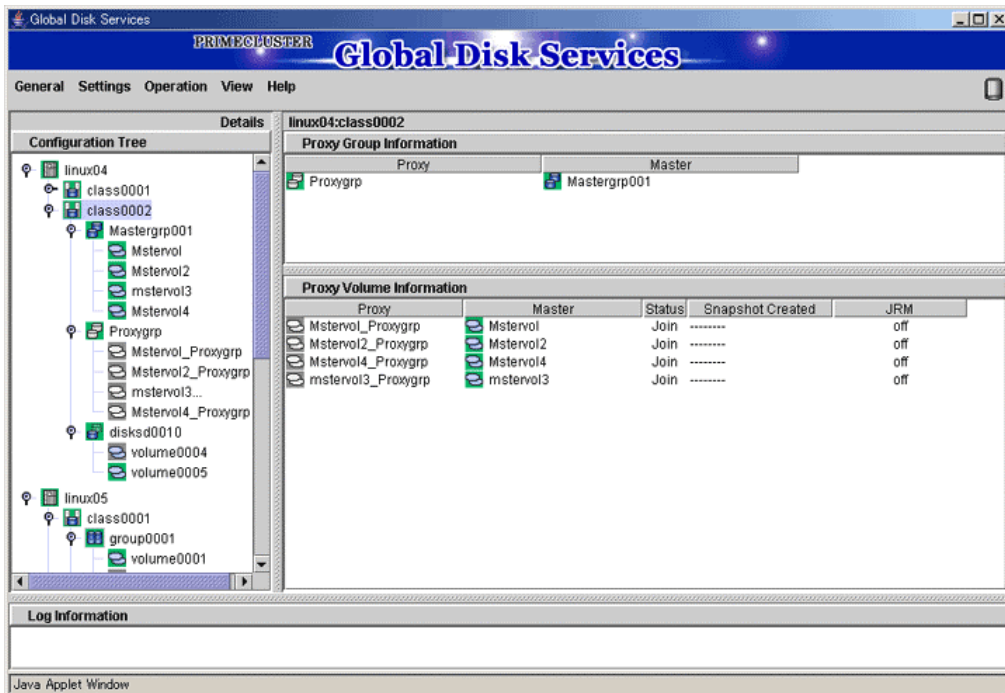

Group-related proxy object configuration

Click a group icon in the GDS Configuration Tree Field to view the following configuration information.

- All the master groups or proxy groups related to that group
- All the proxy volumes within that group and within proxy groups related to it

Figure: Main Screen (for Proxy Objects of a Group)

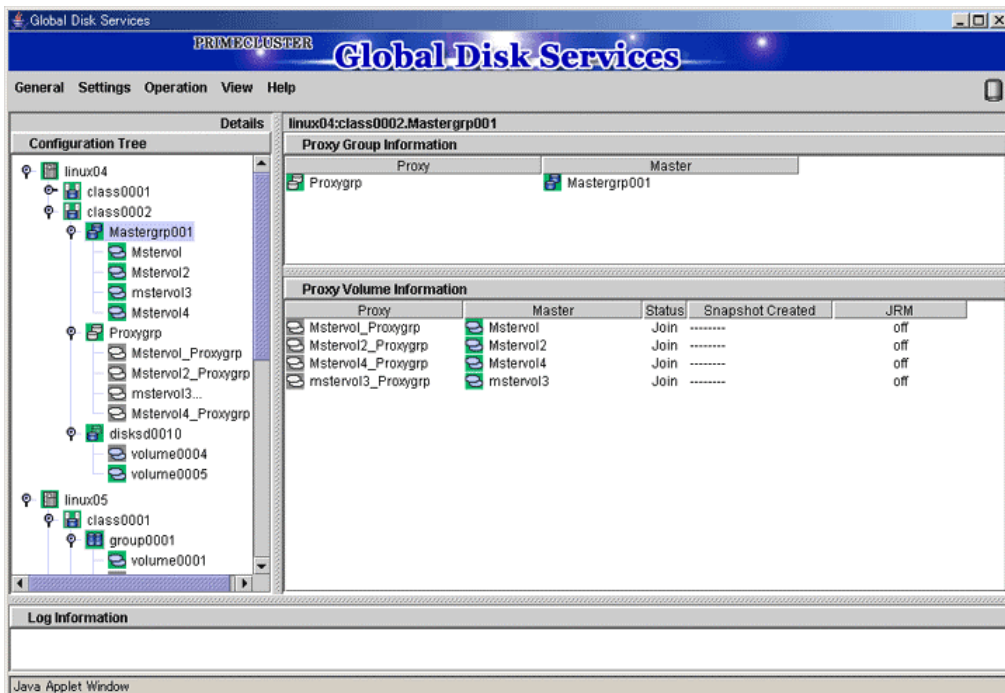

Proxy object configuration within a single disk

Click a single disk icon in the GDS Configuration Tree Field to view all the proxy volumes within that single disk.

Figure: Main Screen (for Proxy Objects of a Single Disk)

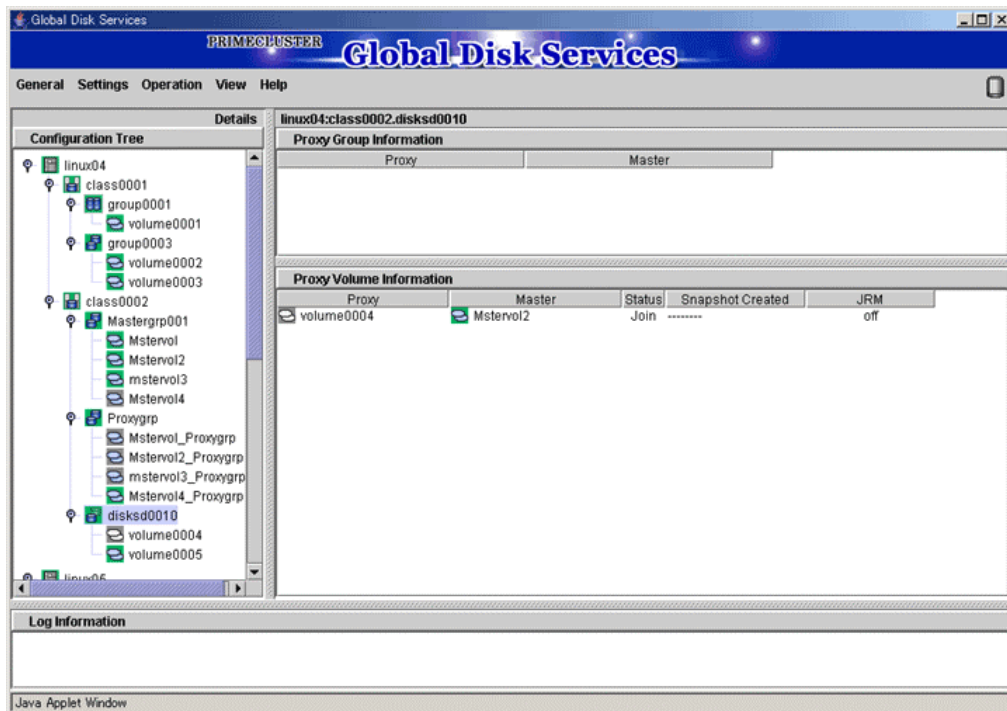

Volume-related proxy object configuration

Click a volume icon in the GDS Configuration Tree Field to view the following configuration information.

- All the master volumes or proxy volumes related to that volume
- All the slices within that volume or within volumes related to it

Figure: Main Screen (for Proxy Objects of a Volume)

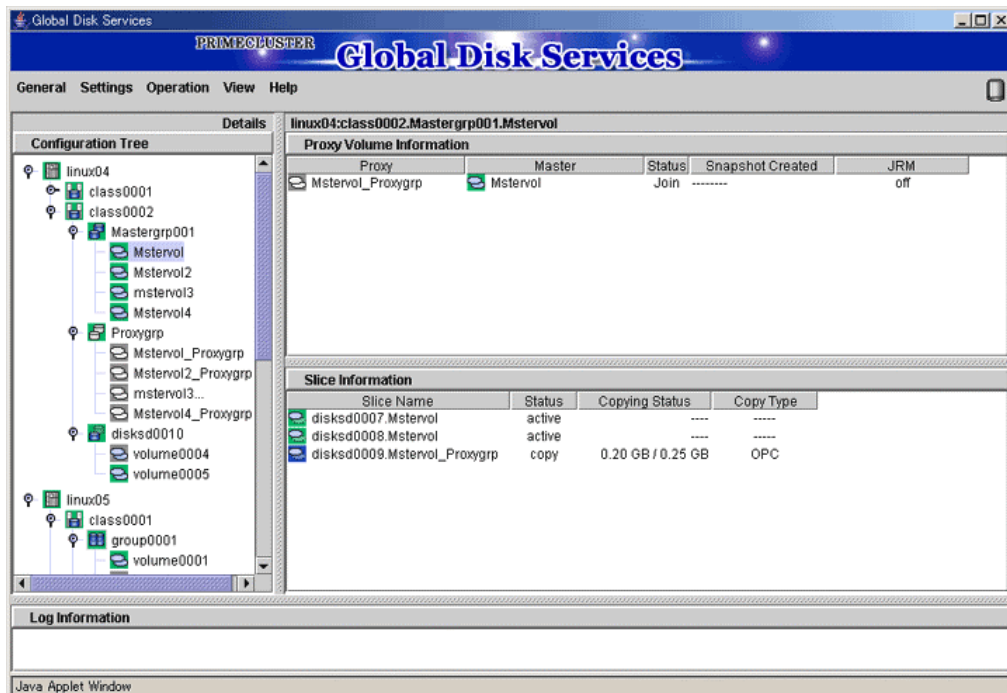

5.3.1.3 Monitoring Object Status

You can monitor the object status from the main screen. Object status will be updated at intervals specified in [Change Monitoring Intervals] in the [General] menu. You may also use [Update] in the [View] menu to update the status immediately. When an abnormality is detected with objects, a warning lamp (yellow/red) will flash. Clicking the flashing lamp will change the lamp to a lit-up lamp.



See

For details about warning lamps, see "4.1 Screen Configuration."

When the object status changes such as by detection of the failed disk, the icon color and description in the status field will change as well.



See

For details about icons, see "4.3 Icon Types and Object Status."

If a disk unit fails during operation, an icon of the disk in which an error is detected will turn red.

Perform recovery work, following procedures described in "5.3.4 Disk Swap."

Figure: Object Status Monitoring in Main Screen

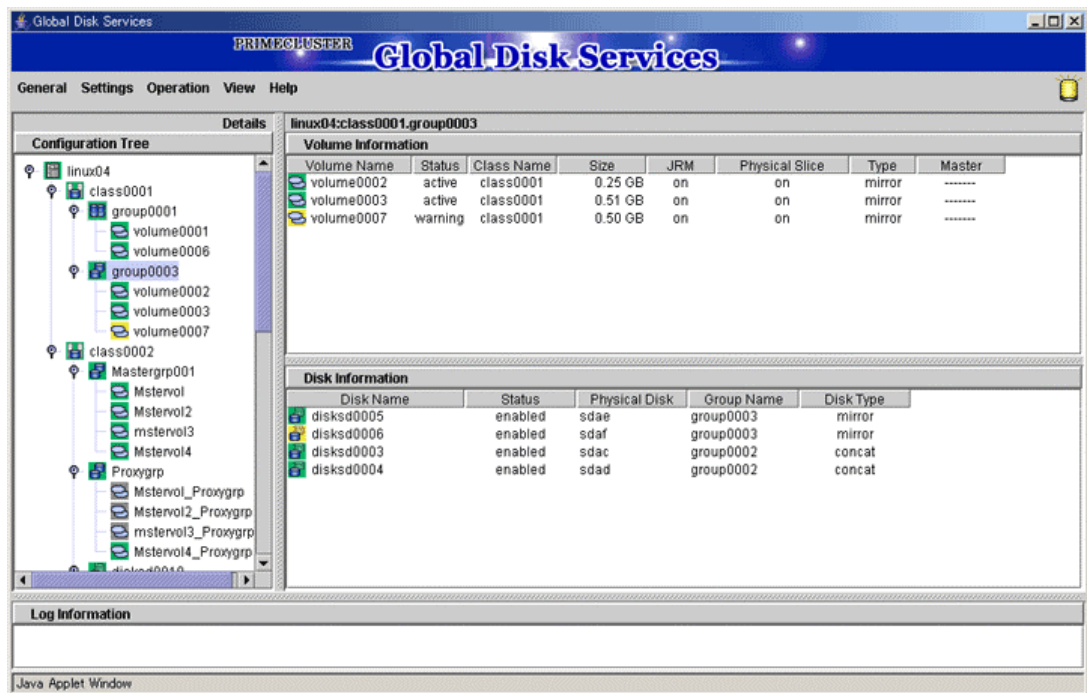

Clicking [Abnormal Object] in the [View] menu will only display objects with abnormalities, making it easy to resolve the problem even when a number of disks are connected.

Figure: Main Screen when [View]: [Abnormal Object] is selected

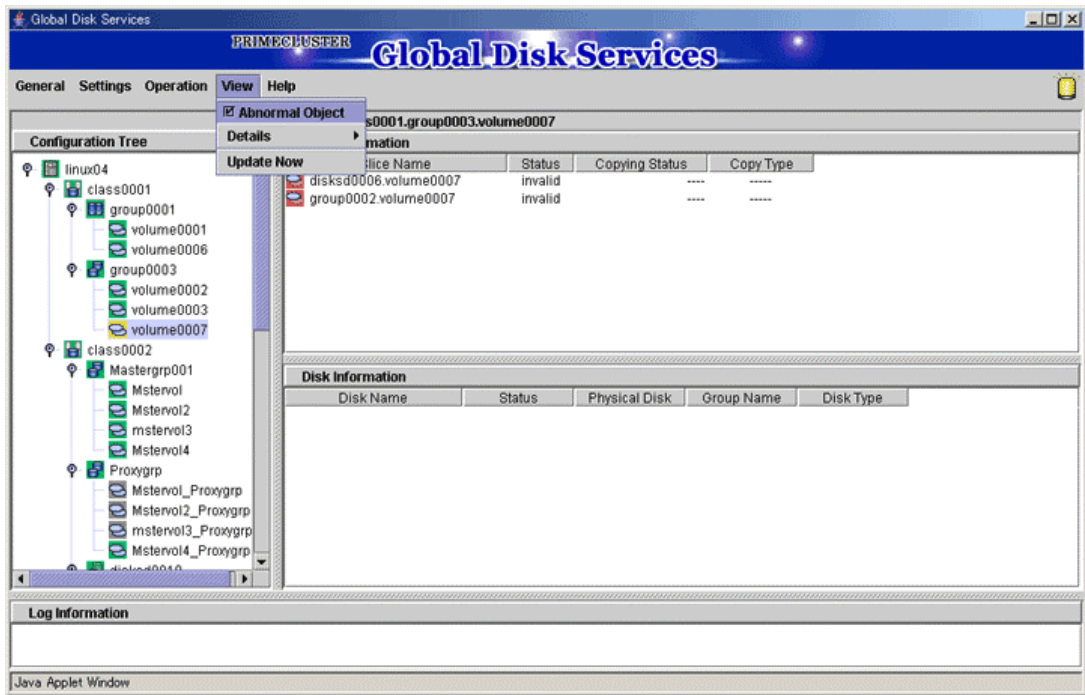

Note Abnormality Detected with GDS Management

What GDS Management displays as abnormal is limited to objects detected by GDS. Therefore, even if the disk unit may have a hardware abnormality, it will be displayed as normal until it is accessed, and the abnormality is detected.

5.3.2 Backup

GDS is software that provides a highly reliable system environment at times of failure, allowing you to continue normal service.

However, using a mirrored system environment does not guarantee absolute safety.

Computer problems could occur due to hardware, software, operation error and poor environment.

A reliable method for working around to such problems is creating "backups." To minimize the damage caused by trouble, periodical backup is strongly recommended.

5.3.2.1 Backup (by Slice Detachment)

This section describes the procedure for creating backup of a mirror volume making use of a snapshot by detaching a slice. This method requires the following "slice operations."

- Detach Slice
- Attach Slice



Note Use Conditions on Snapshot by Slice Detachment

Slices can be detached only from mirror volumes with physical slices. In other words, if disks are not connected directly to mirror groups, creation of snapshots by slice detachment is impossible.



Information Restore

When data is restored back to a volume using data backed up in this procedure, data is restored for the access path to that volume, `/dev/sfdsk/Class Name/rdisk/Volume Name`. For details, see " 6.1.3 Restoring."

Slice Detachment

In order to create a backup, you must temporarily exclude one of the slices from volume, and make it accessible as a separate volume.

The procedures are explained below.

- 1. Displaying the volume status including the slice**
In the main screen, display the volume containing the slice for which you want to create a backup. Click the icon and [Slice Information] appears.
- 2. Selecting the slice to detach**
In the Slice List, select the slice you want to detach by clicking its icon.
- 3. Selecting [Detach Slice] menu**
In the main screen [Operation] menu, click [Detach Slice].

Figure: Detach Slice

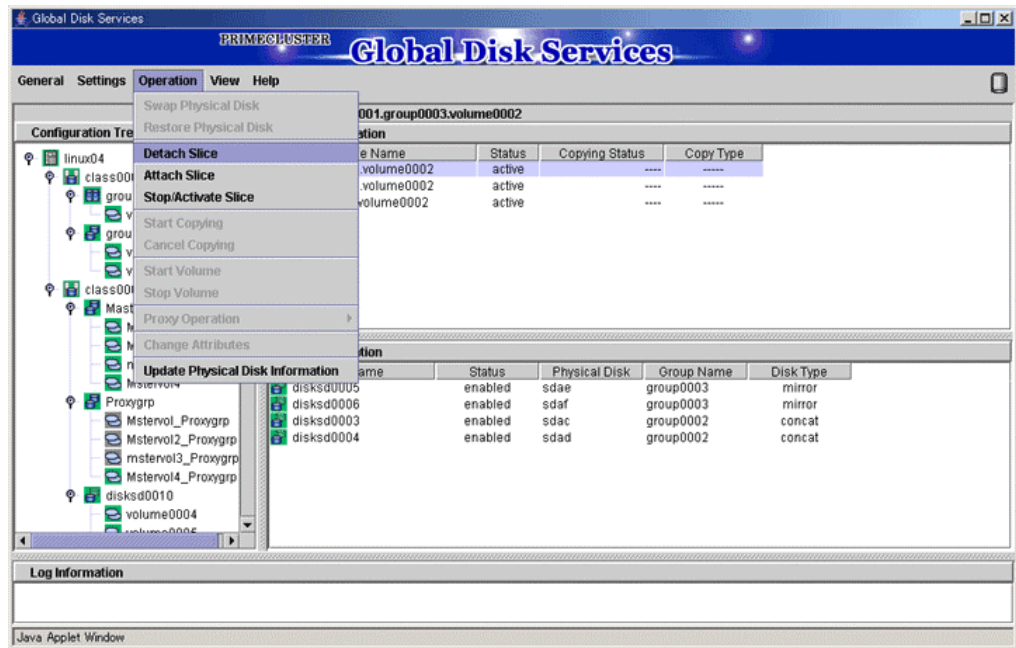

4. **Setting the environment of the detaching slice**
 We will set the environment of the detaching slice.

Figure: Setting the environment of the detaching slice

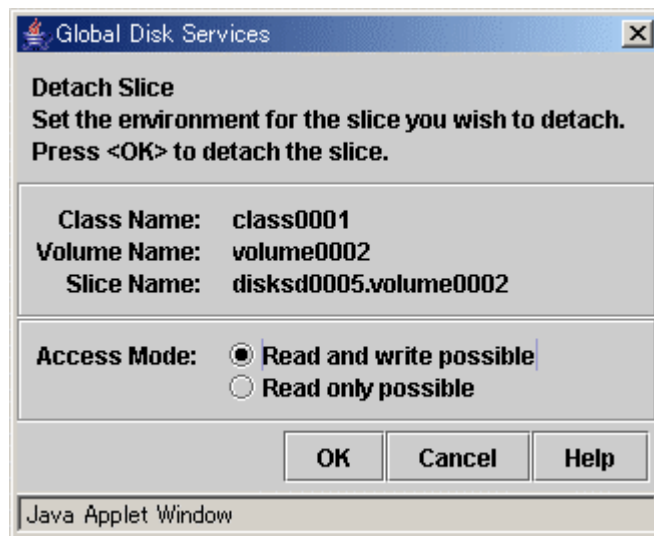

- a) **Access Mode**
 Set the access mode of the detached slice.
 Default is set to [Read and write possible].
 When you specify [Read only possible], the detached mirror slice will be available for read only. Opening a read-only slice in write mode will result in an error.

Press <OK> after setting the environment. If you press <Cancel>, the detaching of the slice will be cancelled.



Note Slice status available for [Detach Slice]

You can only perform [Detach Slice] operation to slices that are in either "active" or "stop" status.

The confirmation screen shown below appears.
To proceed, press <Yes>. Pressing <No> cancels the [Detach Slice] process.

Figure: Confirming Slice Detach

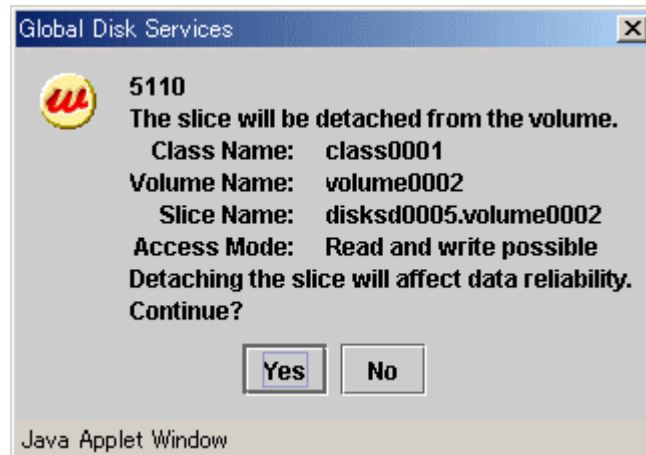

5. Backup Using Access Path

Press <Yes>, and message notifying the completion of detach slice appears.
Use the access path specified in the message to proceed with backup.

Figure: Notifying Detach Slice Complete

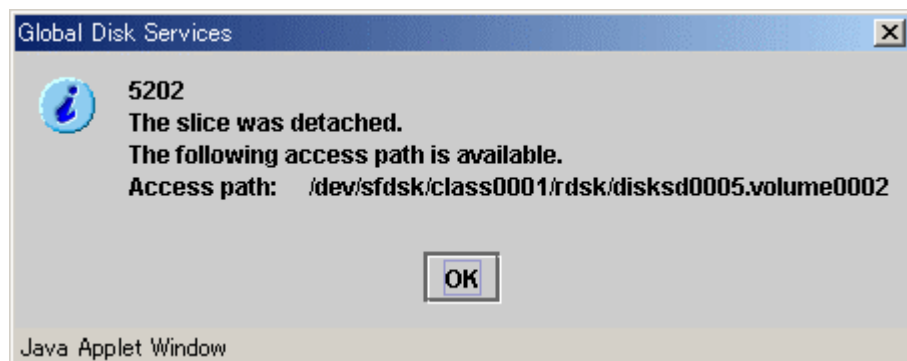

Attach Slice

After the backup is complete, the slice that was temporarily detached will be attached to the volume again.
If the volume is activated, synchronization copying will begin.
The procedures are explained below.

1. Selecting the slice to attach

In the Slice Information field, select the mirror slice you want to attach by clicking its icon.

2. Selecting [Attach Slice] menu

In the main screen [Operation] menu, click [Attach Slice].

Figure: Attach Slice

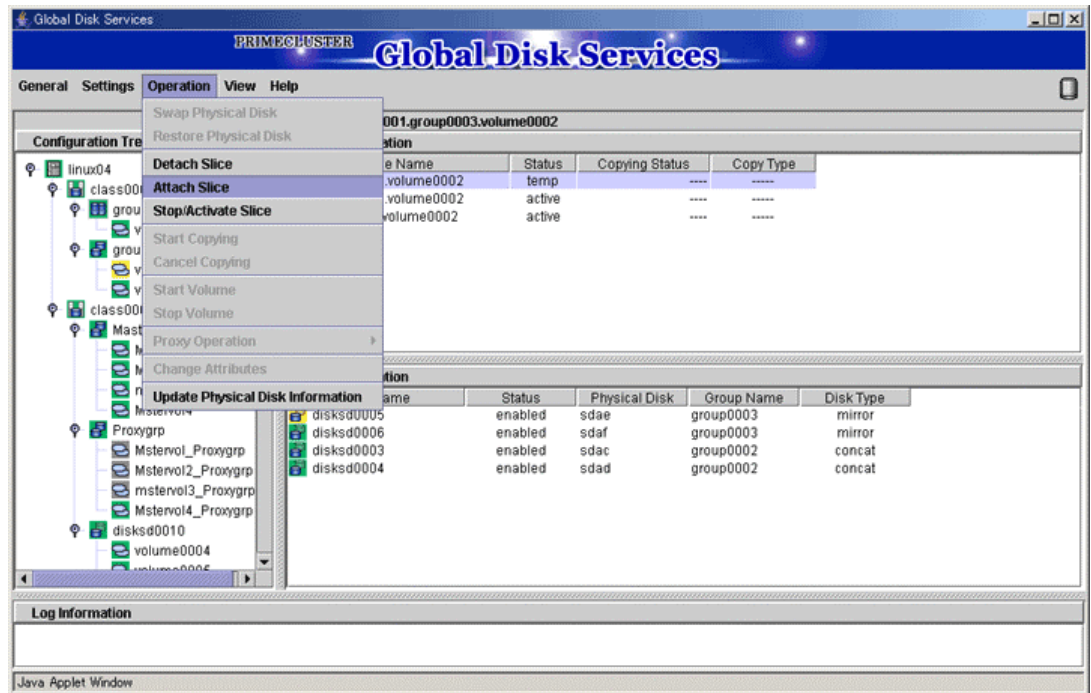

The confirmation screen shown below appears.
To proceed, press <Yes>. Pressing <No> cancels the [Attach Slice] process.

Figure: Confirming "Attach Slice"

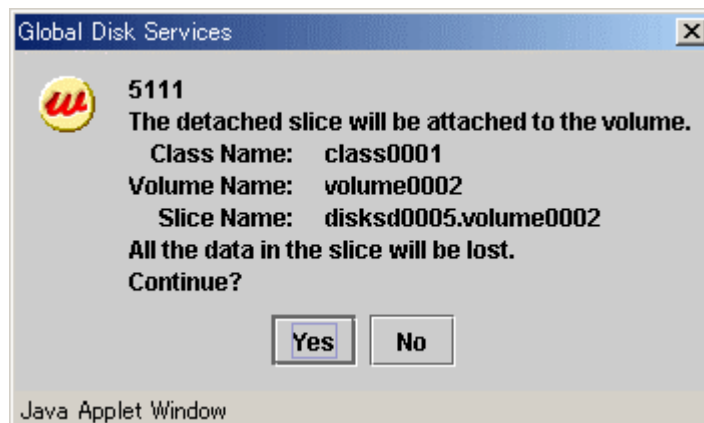

3. Notifying the completion of Attach Slice

Press <OK>, and a message notifying the completion of Attach Slice appears.

Figure: Notifying Attach Slice Completion

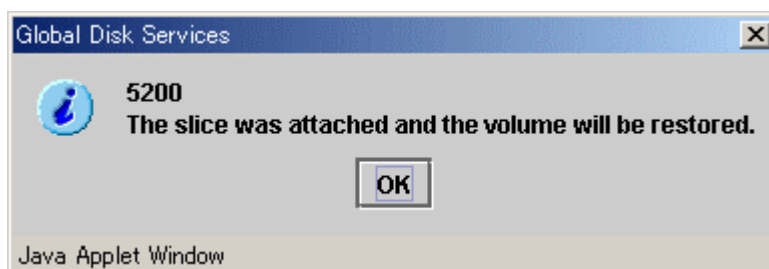

Reliable Backup Procedures

Although the procedure above allows you to use the volume as it is after preparing backup, reliability is affected since one of the slices is excluded.

To ensure reliability, temporarily add a backup disk and perform synchronization copying. After its completion, exclude the slice.

For safe and reliable backup, follow the procedures below.

1. Register backup disk with class.
2. Connect backup disk to group.
3. After completing synchronization copying, stop service.
4. Detach slice.
5. Resume service.
6. Perform backup using access path for backup.
7. Attach slice.
8. Disconnect backup disk from group.
9. Remove backup disk from class.

Completing procedures 1 and 2 in advance will save the waiting time for synchronization copying in procedure 3, therefore reducing the time required for backup.



Note Perform [Detach Slice] after Stopping Service

To ensure integrity of backup data, always stop service before excluding the slice.

You may resume service once [Detach Slice] is complete. You do not have to suspend service during the actual backup process.

When excluding the slice without stopping service, run host programs such as fsck (in case of file system) as necessary.

Stop/Activate Slice

Stop Slice

In order to protect data of the slice which has been detached to prepare for backup, a slice with "temp" status will temporarily become inaccessible.

1. **Selecting the slice to stop**
In the Slice Information Field, select the slice you want to stop by clicking the "temp" status slice icon.
2. **Selecting [Stop/Activate Slice] menu**
In the main screen [Operation] menu, click [Stop/Activate Slice].

Figure: Stop Slice

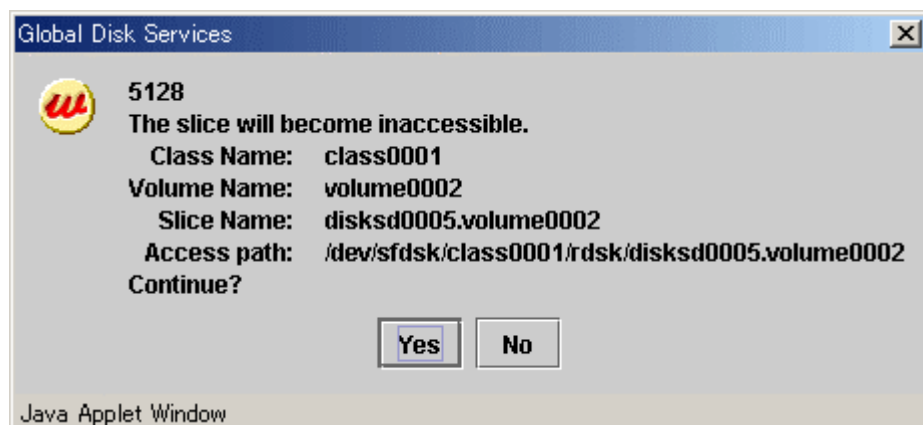

To proceed, press <Yes>. Pressing <No> cancels the [Stop Slice] process.

Activate Slice

Reactivate the slice that has become inaccessible ("temp-stop" status) as a result of performing [Stop Slice] operation or switching of the nodes, and make it accessible.

1. Selecting the slice to activate

In the Slice Information Field, select the slice you want to reactivate by clicking the "temp-stop" status slice icon.

2. Selecting [Stop/Activate Slice] menu

In the main screen [Operation] menu, click [Stop/Activate Slice].

Figure: Activate Slice

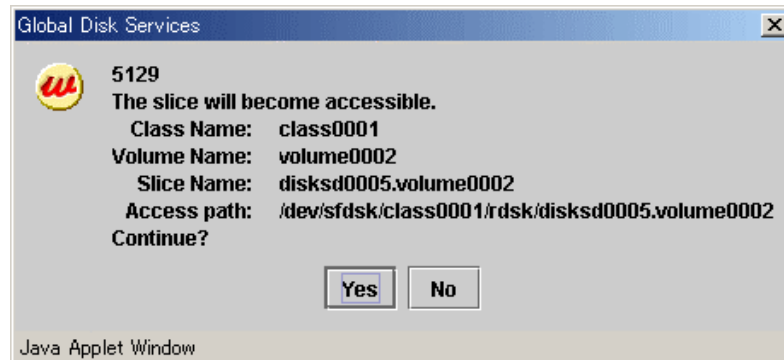

To proceed, press <Yes>. Pressing <No> cancels the [Activate Slice] process.

5.3.2.2 Backup (by Synchronization)

This subsection describes the procedures for backing up volumes through use of snapshots of GDS Snapshot by synchronization. This method requires the following "Proxy Operations".

- Join
- Part
- Rejoin
- Break



Point Keep Proxies Parted If Possible

If proxies are kept parted, they can be used for master data restoration. Therefore, it is recommended to keep proxies parted if possible. For the restore procedures see "5.3.3 Restore."



Note "Part" Proxies after Stopping Services

To ensure integrity of backup data, always stop services before executing "Part". You may resume the services once "Part" is complete. It is unnecessary to stop services when backing up data to tape and so on.

For details, see "A.2.15 Ensuring Integrity of Snapshot Data."



Note Snapshot by Synchronization Use Conditions

See the following sections for points of concern.

"A.1.7 Exception to Proxy Configuration"

"A.1.8 Number of Proxy Volumes"

"A.1.9 Proxy Volume Size"

"A.1.10 Proxy Group Size"



Information Use Conditions for Copy Functions of Disk Units

See "A.2.13 Using the Advanced Copy Function in a Proxy Configuration."

Join

Join a volume for backup (a proxy volume) to a volume to be backed up (a master volume).

To back up all the volumes within a group simultaneously, join a group for backup (a proxy group) to a group to be backed up (a master group).

For the "Join" procedures see "5.2.3.1 Join."

Part

Make sure that synchronization copying from a master to a proxy is complete in the Main Screen, and part the proxy from the master.

Follow the procedures below.

1. Selecting a proxy to be parted

Click a master volume icon on the GDS Configuration Tree in the Main Screen.

To back up all the master volumes within a master group simultaneously, click the master group icon.

Select [View]: [Details]: [Proxy Object] to view all the proxy objects related to the master object selected on the GDS Configuration Tree, in the Object Information Field. In this field, click an icon of a proxy volume or a proxy group used for backup.



Note Proxy Objects That Can Be Parted

Proxy volumes can be parted if they are joined and if copy is complete.

2. Selecting the [Part] menu

Select [Operation]: [Proxy Operation]: [Part].

Figure: Part

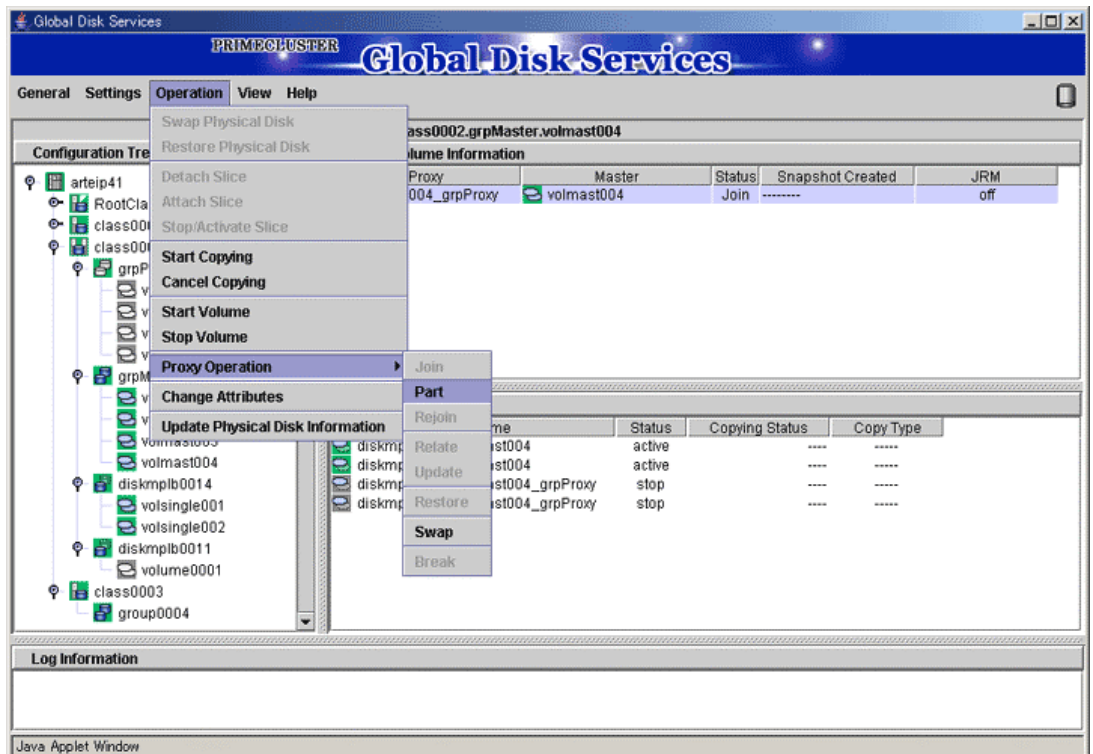

3. Setting the environment for parting the proxy

The Part Proxy dialog box appears.

Figure: Setting the Part Environment



Set the environment for parting the proxy.

a) Instant Snapshot

Specify whether to change the synchronization mode to the OPC mode.

The default value is "No". If synchronization copying from the master to the proxy is incomplete, the part process will fail.

If this option is set to "Yes", instant snapshots are created with the OPC function. Even if synchronization copying from the master to the proxy is in progress, the proxy will be parted and then background copying from the master to the proxy will be executed with the OPC function. If the OPC function is unavailable, the part process will fail.



Note Instant Snapshot by OPC Use Conditions

See the following sections.

"A.2.13 Using the Advanced Copy Function in a Proxy Configuration"

"A.2.14 Instant Snapshot by OPC"

b) Just Resynchronization Mechanism

Set the mode of Just Resynchronization Mechanism (JRM) for proxies. The default value is "on".



See

For details about JRM for proxies, see "A.2.10 Just Resynchronization Mechanism (JRM)."

c) Access Mode

Set the access mode of the parted proxy volume.

The default value is "Read Only". The parted proxy volume will be read-only and an error occurs if it is opened in write mode.

To permit write access to the parted proxy volume, set this option to "Read/Write".

After the settings are complete, click <OK>. Clicking <Cancel> cancels the part process.

4. Information message of the completion

A message window appears informing you that the part process is complete.

Figure: Information Message of "Part" Completion

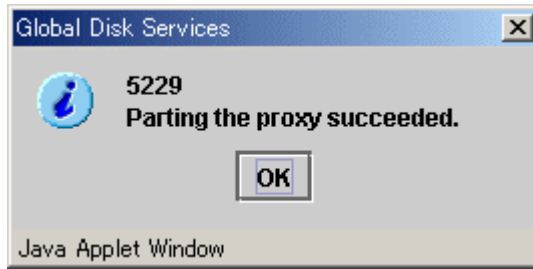

Click <OK> to close the information message window.

Back up data through use of the proxy volume.

Rejoin

To re-execute backup, rejoin a parted proxy to a master. Follow the procedures below.

1. Selecting a proxy to be rejoined

Click an icon of a master volume to be backed up on the GDS Configuration Tree in the Main Screen.

To back up all the master volumes in a master group simultaneously, click the master group icon.

Select [View]: [Details]: [Proxy Object] to view all the proxy objects related to the master object selected on the GDS Configuration Tree, in the Object Information Field. In this field, click an icon of a proxy volume or proxy group used for backup.

2. Selecting the [Rejoin] menu

Select [Operation]: [Proxy Operation]: [Rejoin] in the Main Screen.

Figure: Rejoin

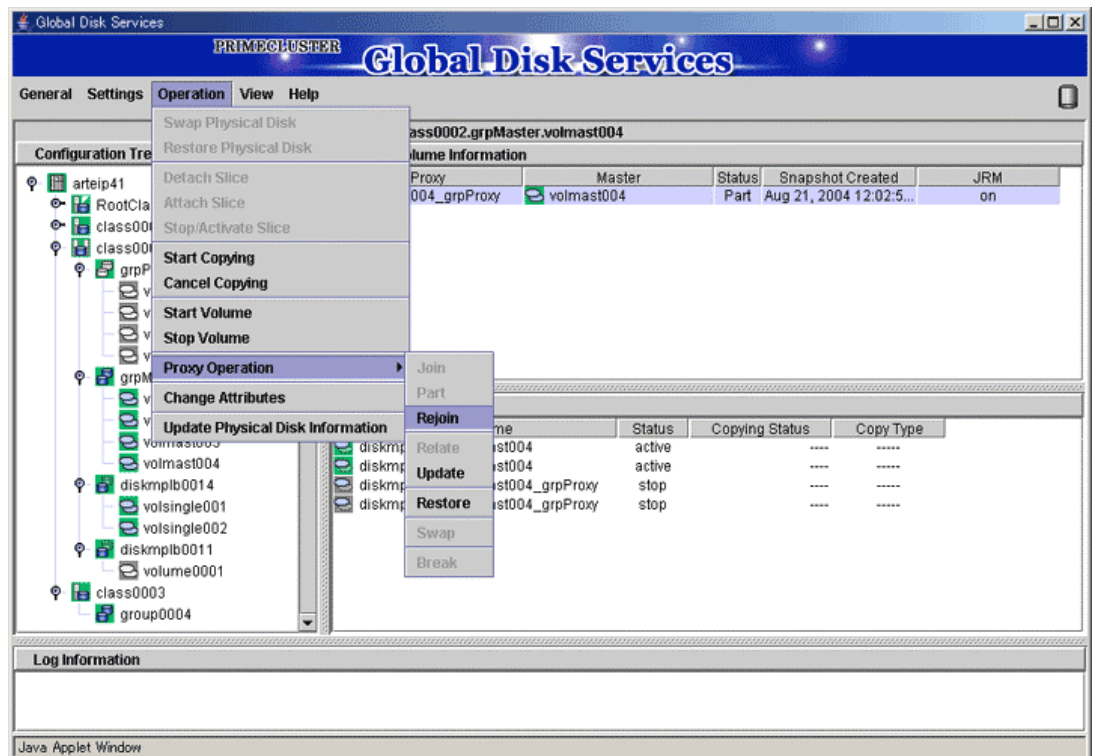

3. Confirming

A confirmation dialog box appears asking you whether to rejoin the proxy.

Figure: Confirming "Rejoin"

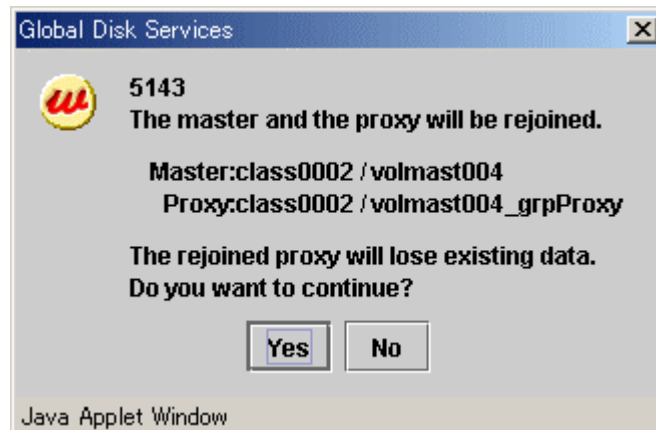

To continue the process, click <Yes>. Clicking <No> cancels the rejoin process.

4. Information message of the completion

A message window appears informing you that the rejoin process is complete.

Figure: Information Message of "Rejoin" Completion

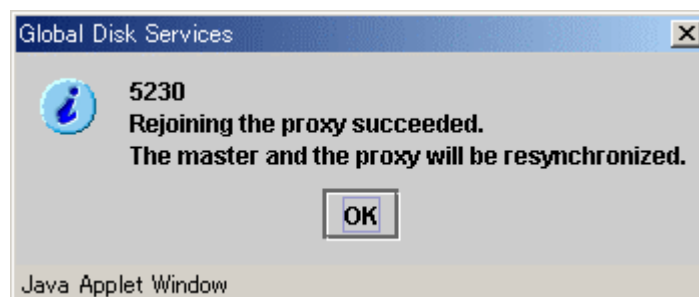

Click <OK> to close the information message window.

Break

If no more backup is necessary, break the relationship between the master and the proxy. For "Break Proxy" procedures see "5.5.5 Breaking a Proxy."

5.3.2.3 Backup (by OPC)

This subsection describes the procedures for backing up volumes through use of snapshots of GDS Snapshot by OPC. This method requires the following "Proxy Operations".

- Relate
- Update
- Break



Note "Update" Proxies after Stopping Services

To ensure integrity of backup data, always stop services before executing "Update". You may resume the services once "Update" is complete. It is unnecessary to stop services when backing up data to tape and so on.

For details, see "A.2.15 Ensuring Integrity of Snapshot Data."



Note Instant Snapshot by OPC Use Conditions

- See the following sections for points of concern.
- "A.1.7 Exception to Proxy Configuration"
- "A.1.8 Number of Proxy Volumes"
- "A.1.9 Proxy Volume Size"
- "A.1.10 Proxy Group Size"
- "A.2.13 Using the Advanced Copy Function in a Proxy Configuration"
- "A.2.14 Instant Snapshot by OPC"

Relate

Relate a volume for backup (a proxy volume) to a volume to be backed up (a master volume).

To back up all the volumes within a group simultaneously, relate a group for backup (a proxy group) to a group to be backed up (a master group).

For the "Relate Proxy" procedures see "5.2.3.2 Relate."

Update

Copy (overwrite) data from a master to a proxy with the OPC function. Follow the procedures below.

1. Selecting a proxy to be updated

Click an icon of a master volume to be backed up on the GDS Configuration Tree in the Main Screen.

To back up all the master volumes in a master group, click the master group icon.

Select [View]: [Details]: [Proxy Object] to view all the proxy objects related to the master object selected on the GDS Configuration Tree, in the Object Information Field. In this field, click an icon of a proxy volume (or a proxy group) used for backup.



Note Proxy Objects That Can Be Updated

Proxy volumes can be updated if they are parted and in "stop" status.

2. Selecting the [Update] menu

Select [Operation]: [Proxy Operation]: [Update] in the Main Screen.

Figure: Update

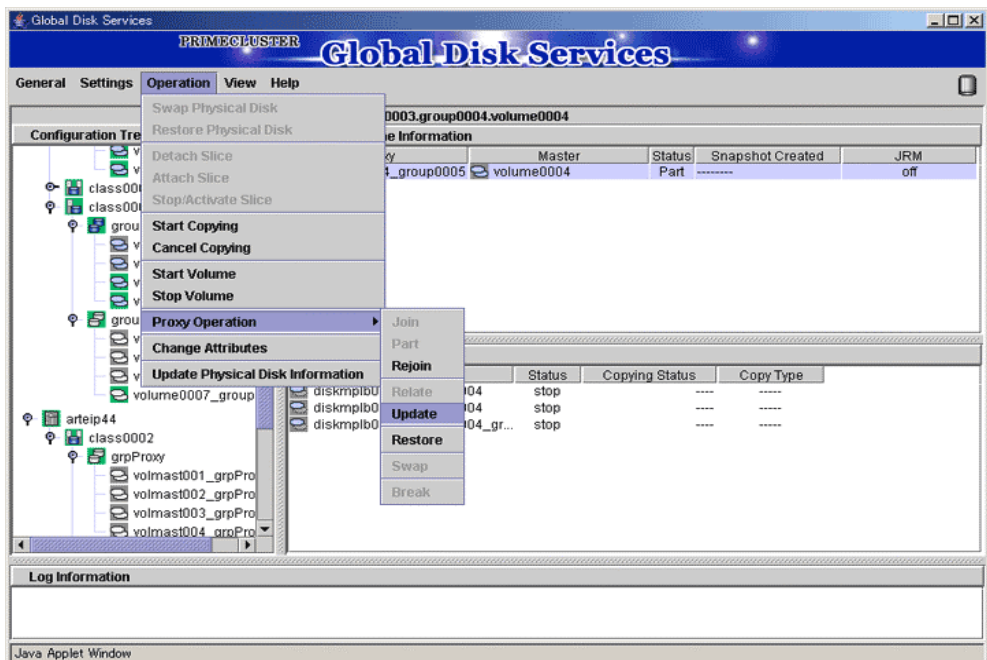

3. Setting the environment for updating the proxy

The Update Proxy dialog box appears.

Figure: Setting the Update Environment

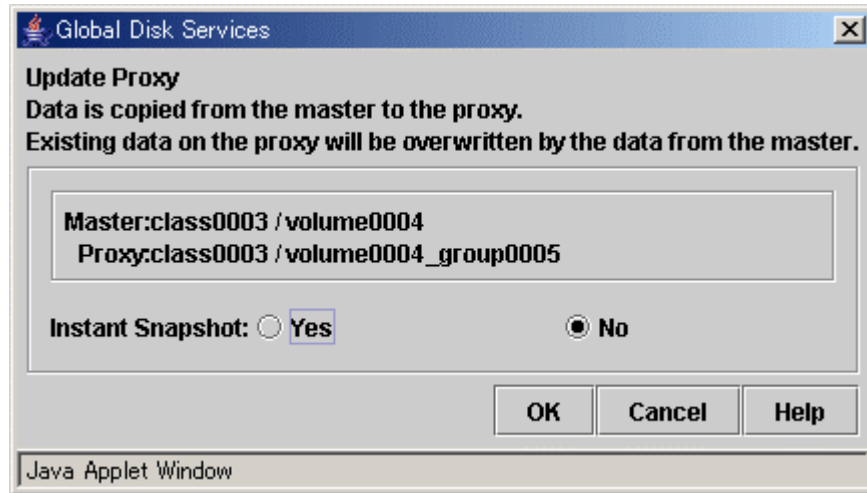

Set the environment for updating the proxy.

- a) Instant Snapshot
Specify whether to apply instant snapshot.

The default value is "No". Wait until copying from the master volume to the proxy volume is complete and start the proxy volume.

To start the proxy volume immediately without waiting until copying from the master volume to the proxy volume is complete, set this option to "Yes".

After the settings are complete, click <OK>. Clicking <Cancel> cancels the update process.

4. Information message of the completion

A message window appears informing you that the update process is complete.

Figure: Information Message of "Update" Completion (No to Instant Snapshot)

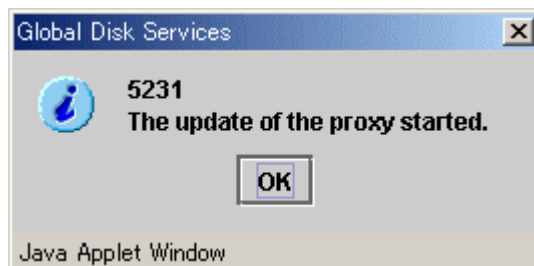

If "No" to "Instant Snapshot" was selected when setting the update environment in step 3, check the copy status in the Main Screen, and after the copy is complete, start the proxy volume and execute backup.

Figure: Information Message of "Update" Completion (Yes to Instant Snapshot)

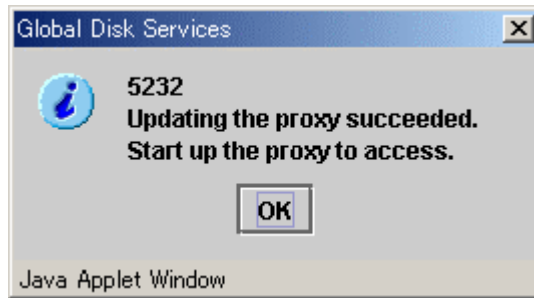

If "Yes" to "Instant Snapshot" was selected when setting the update environment in step 3, you may start the proxy volume and execute backup immediately without waiting until copying is complete.

Break

If no more backup is necessary, break the relationship between the master and the proxy.

For "Break Proxy" procedures see "5.5.5 Breaking a Proxy."

5.3.3 Restore

This subsection describes the procedures for restoring volumes through use of GDS Snapshot proxy volumes. This method requires the following "Proxy Operations".

- Restore

Stop services using a volume to be restored (a master volume) to stop the master volume and then perform the following procedures.

Restore

Copy (overwrite) data from a proxy to a master.
Follow the procedures below.

1. Selecting a proxy as a restore copy source

Click an icon of a master volume to be restored on the GDS Configuration Tree in the Main Screen.

To restore all the master volumes within a master group simultaneously, click the master group icon.

Select [View]: [Details]: [Proxy Object] to view all the proxy objects related to the master object selected on the GDS Configuration Tree, in the Object Information Field. In this field, click an icon of a proxy volume (or a proxy group) as a restore copy source.



Point Backup Generation

Proxy volume data is a replica of master volume data at the moment of snapshot creation. For snapshot creation time, check [Snapshot Created] time in the proxy volume information field.



Note Proxy Volumes That Can Be Restore Copy Sources

Proxy volumes can be restore copy sources if they are parted and in "active" or "stop" status.

However, when selecting "Yes" to "Rejoin" for setting the restore environment in step 3, copy sources must be proxy volumes that are parted and are in "stop" status.

2. Selecting the [Restore] menu

Select [Operation]: [Proxy Operation]: [Restore] in the Main Screen.

Figure: Restore

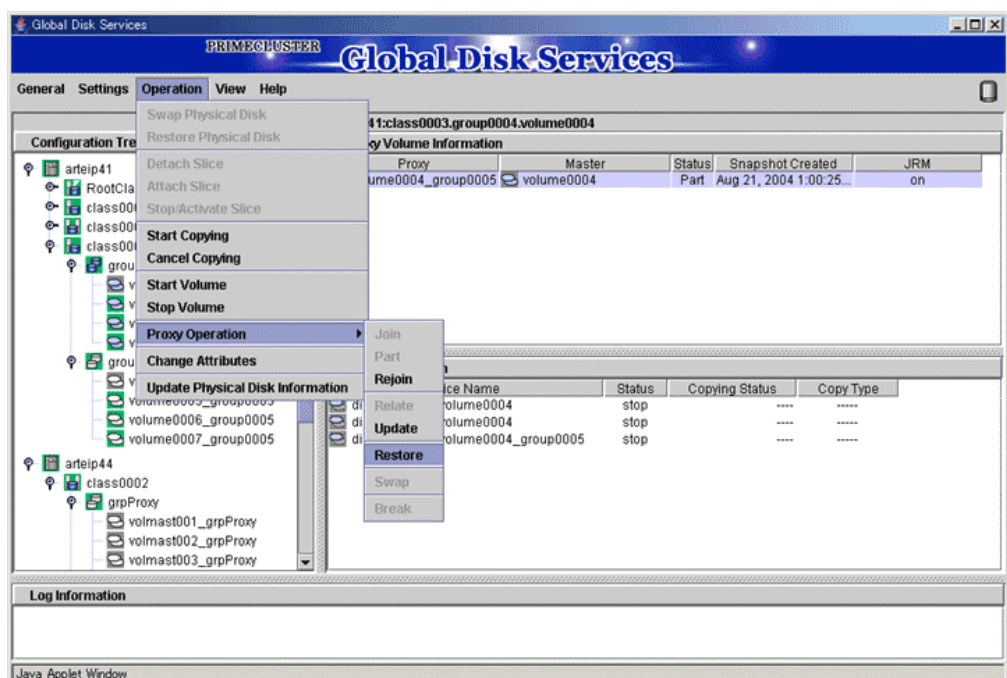

3. Setting the environment for restoring the master

The Restore Master dialog box appears.

Figure: Setting the Restore Environment

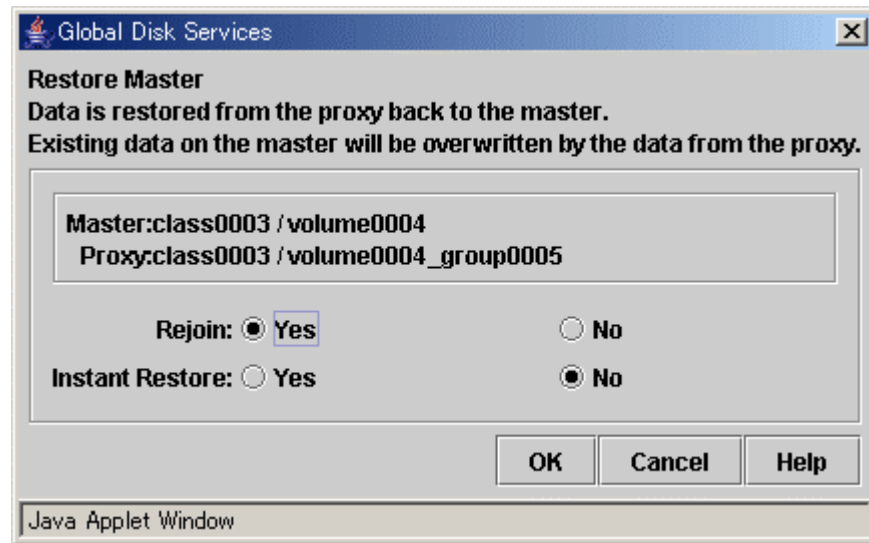

Set the environment for restoring the master.

- a) Rejoin
Specify whether to rejoin the master and the proxy.

The default value is "Yes". The master and the proxy will be joined, and after copy is complete they will be synchronized. If the OPC function is unavailable, select "Yes".

To leave the master and the proxy parted and execute restore with the OPC function, set this option to "No".



[See](#)

For the OPC function use conditions, see the following sections.
"A.2.13 Using the Advanced Copy Function in a Proxy Configuration "
"A.2.14 Instant Snapshot by OPC"



Note Master Volumes with Mirroring Multiplicity of Two and Higher

Even if the device supports the OPC function, selecting "Yes" to "Rejoin" disables the OPC function. To use the OPC function for restoration, select "No" to "Rejoin". However, slices other than the OPC copy destination will be excluded from mirroring and the data statuses will be invalid. To restore the master volume mirroring status, select the master volume and execute [Operation]: [Start Copying] in the Main Screen. If not executing [Start Copying], resynchronization copying automatically starts when the master volume starts.

- b) Instant Restore
Specify whether to apply instant restore

The default value is "No". Wait until copying from the proxy volume to the master volume is complete and start the master volume.

To start the master volume immediately without waiting until copying from the proxy volume to the master volume is complete, set this option to "Yes".



Note If "Yes" to "Rejoin" and "Yes" to "Instant Restore" Are Selected

Even if synchronization copying from the proxy to the master is in progress, the master volume can be started and accessed. Note, however, that the master and the proxy are joined and data written to the master is also written to the proxy. To prevent proxy data from being updated, wait until copying is complete and execute "Part" before starting the master volume.

After the settings are complete, click <OK>. Clicking <Cancel> cancels the restore process.

4. Information message of the completion

A message window appears informing you that the restore process is complete.

Figure: Information Message of "Restore" Completion (Yes to Rejoin/No to Instant Restore)

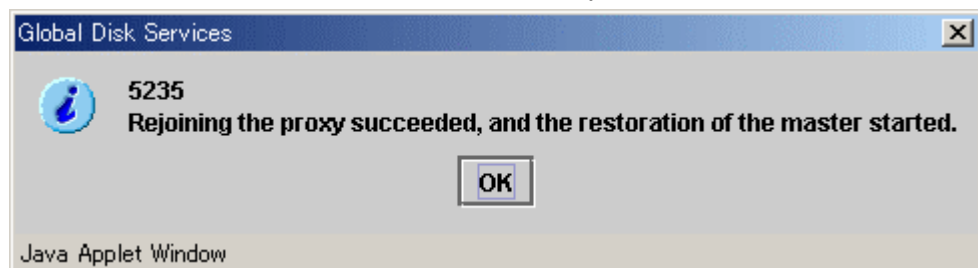

If "Yes" to "Rejoin" and "No" to "Instant Restore" were selected when setting the restore environment in step 3, the master and the proxy are joined. Wait until resynchronization copying from the proxy to the master is complete and start the master volume.

Figure: Information Message of "Restore" Completion (Yes to Rejoin/Yes to Instant Restore)

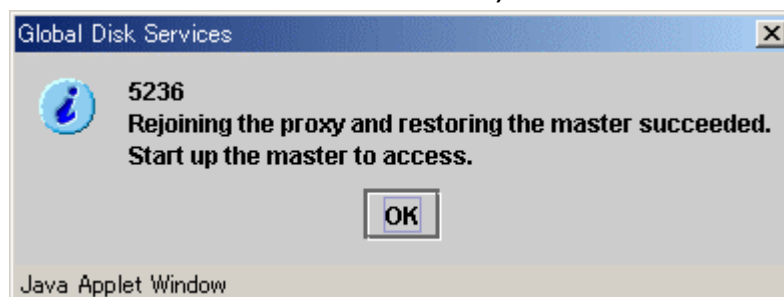

If "Yes" to "Rejoin" and "Yes" to "Instant Restore" were selected when setting the restore environment in step 3, the master and the proxy are joined. You may start the master volume immediately without waiting until resynchronization copying from the proxy to the master is complete.

Figure: Information Message of "Restore" Completion (No to Rejoin/No to Instant Restore)

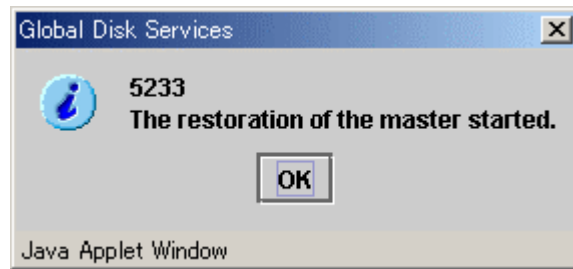

If "No" to "Rejoin" and "No" to "Instant Restore" were selected when setting the restore environment in step 3, the master and the proxy are left parted. Wait until OPC copying from the proxy to the master is complete and start the master volume. If the OPC function is unavailable, the restore process fails.

Figure: Information Message of "Restore" Completion (No to Rejoin/Yes to Instant Restore)

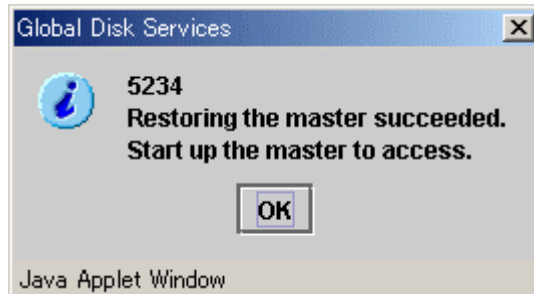

If "No" to "Rejoin" and "Yes" to "Instant Restore" were selected when setting the restore environment in step 3, the master and the proxy are left parted. You may start the master volume immediately without waiting until OPC copying from the proxy to the master is complete. If the OPC function is unavailable, the restore process fails.

Break

If no more backup is necessary after the restore, break the relationship between the master and the proxy.

For "Break Proxy" procedures see " 5.5.5 Breaking a Proxy."

5.3.4 Disk Swap

When a disk unit abnormality occurs, contact your local customer support to swap the disk units. When using GDS, the following procedures are necessary before and after the disk swap:

- swap physical disk
- restore physical disk



Note Identifying a Failed Disk Unit

You should pinpoint a hardware error on a disk unit based on, for example, log messages for the disk driver output in the `/var/log/messages` file. For details, see "F.1.9 Disk Unit Errors."



Note Physical Disk Size

Physical disks cannot be swapped with disks that are smaller in size.



Note Physical disks that can not be swapped

Physical disk swap is impossible with a disk that includes the only valid slice, which has "active" or "stop" status, within the volume.

For example, disk swap is impossible when:

- The volume is in a group to which only one disk is connected.
- The volume is on a single disk that is not connected to a group.

To perform physical disk swap here:

- a. When the relevant disk is connected to a mirror group, add a new disk to the mirror group and wait until volume synchronization copying ends normally.
- b. When the relevant disk is a single disk, add the single disk and another unused disk to a new mirror group and wait until volume synchronization copying ends normally.
- c. Remove volumes that reside in the relevant disk. Be sure to back up volume data in advance.

When swapped disk data is valid, for example in the case of preventive maintenance, the methods a) and b) are recommended. In this case, if disk units support the hot swap function, disks can be swapped while applications are operating.



Note Swapping a Disk Unit Registered with a Shadow Class for Another Disk Unit

To swap a disk unit registered with a GDS Snapshot shadow class (shadow disk) for another disk unit, the shadow disk must first be removed with the GDS Snapshot command. For details about GDS Snapshot commands, see "Appendix D Command Reference."

The subsequent operations are different depending on whether or not the swapped disk is registered with a disk class.

- When the swapped disk unit is registered with a disk class
After removing the shadow disk, swap disk units following this procedure in the domain managing the disk class.
When an error occurs on a disk unit, both of the related SDX and shadow objects do not necessarily become invalid. Even if one of those objects becomes invalid, removing the shadow disk and swapping disk units following this procedure are both necessary.
- When the swapped disk unit is not registered with a disk class
The swapped disk unit is the destination for the disk unit's copy function here. Physical disk swapping and restoring as described in this procedure is not required. After removing the shadow disk, swap disks referring to a manual for the disk unit's copy function.

Swap Physical Disk

In order to swap the disk units, you must take the physical disk offline. The procedures are explained below.

- 1. Displaying the status of physical disk**
In the main screen, display the physical disk to be swapped. Click the icon and select the physical disk.
- 2. Selecting [Swap Physical Disk]**
In the main screen [Operation] menu, select [Swap Physical Disk].

Figure: Swap Physical Disk

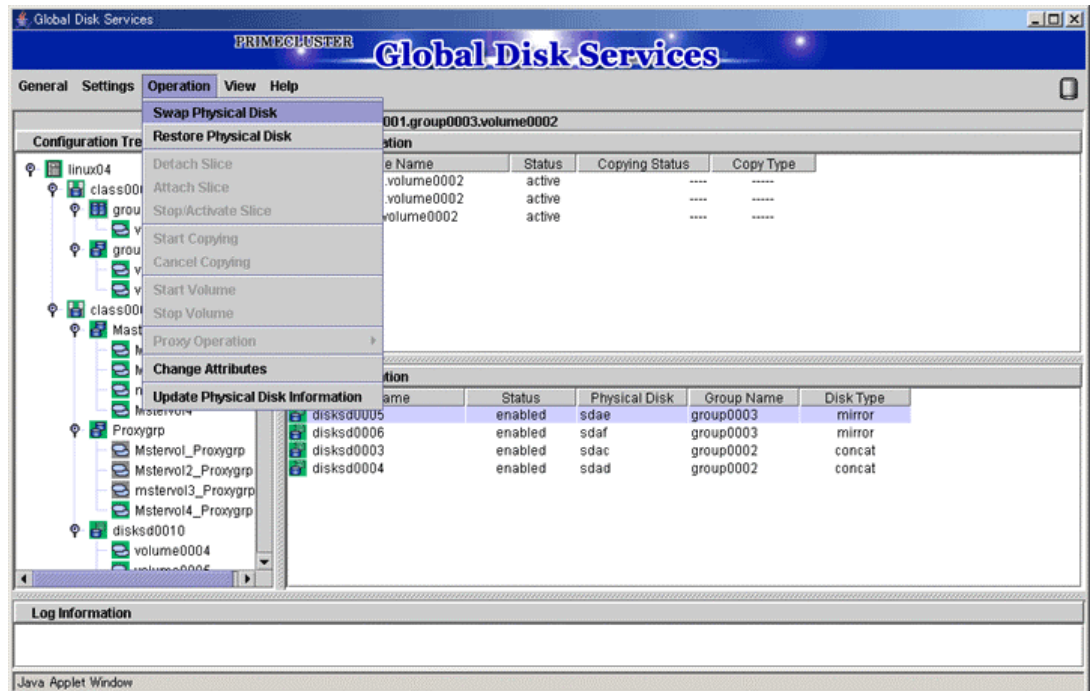

The confirmation screen shown below appears. To proceed, click <Yes>. Clicking <No> cancels the [Swap Physical Disk] process.

Figure: Confirming Swap Physical Disk

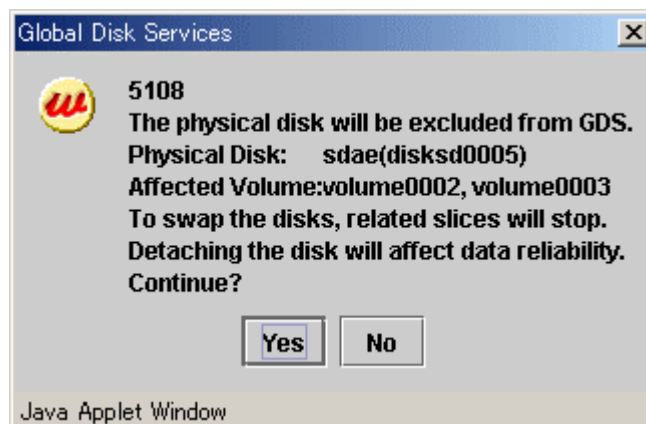

3. Requesting the swap of physical disks

Click <Yes>, and a message notifying the offline status appears.

Click <OK>, and request your local customer support to swap the disk unit.

Figure: Notifying Offline Completion



Restore Physical Disk

After swapping the disk units, you must put the swapped physical disk back online. The procedures are explained below.

1. Selecting the physical disk to restore

Select the physical disk you want to restore.

2. Selecting [Restore Physical Disk] menu

In the main screen [Operation] menu, select [Restore Physical Disk].

Figure: Restore Physical Disk

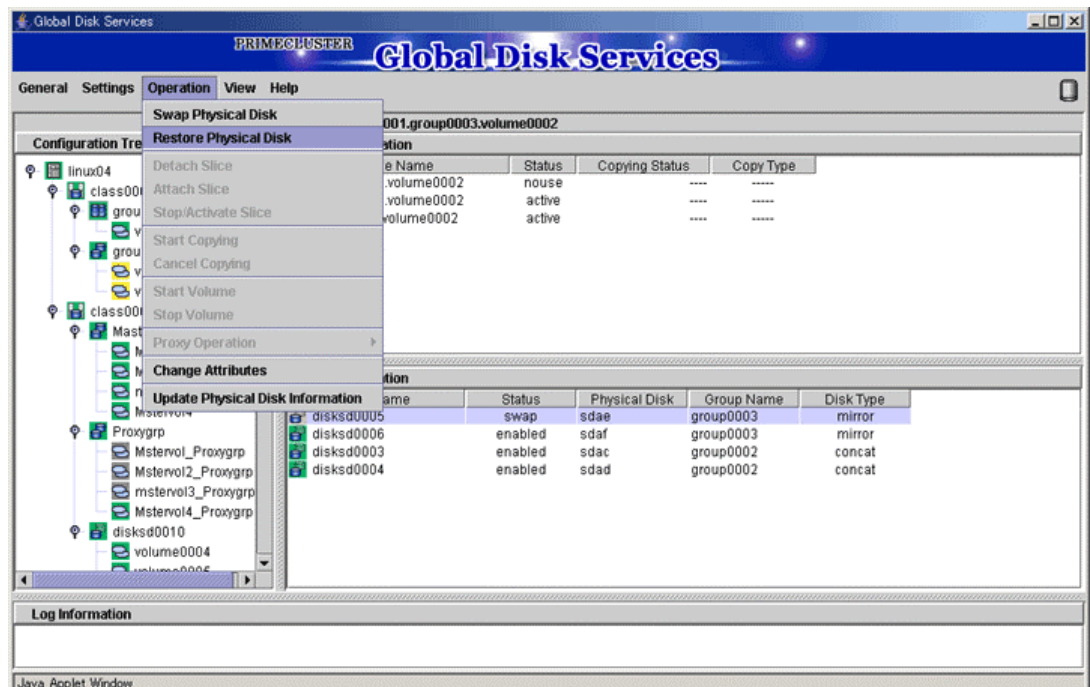

The confirmation screen shown below appears.

To proceed, click <Yes>. Clicking <No> cancels the [Restore Physical Disk] process.

Figure: Confirming Restore Physical Disk

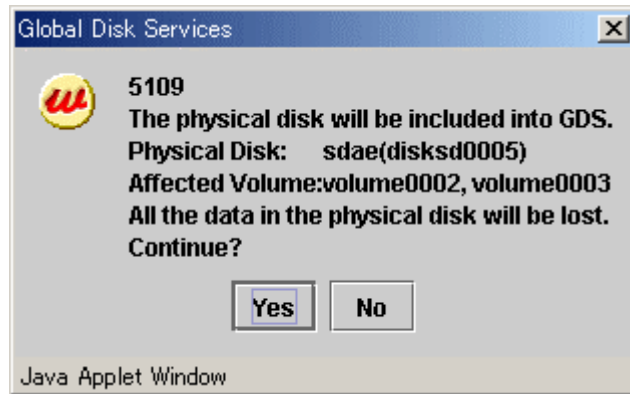

3. Notifying online status

Click <OK>, and a message notifying the online status appears.

Figure: Notifying Online Completion

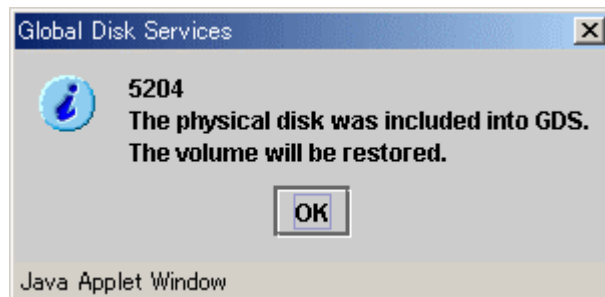

5.3.5 Disk Migration

This subsection describes the procedures for transferring volumes to other disks through use of GDS Snapshot proxy volumes. This method requires the following "Proxy Operations".

- Join
- Swap Slice
- Break



Note Proxy Volume Use Conditions

See the following sections for points of concern.

"A.1.7 Exception to Proxy Configuration "

"A.1.8 Number of Proxy Volumes"

"A.1.9 Proxy Volume Size"

"A.1.10 Proxy Group Size"

Join

Join a destination volume (a proxy volume) to a volume for disk migration (a master volume).

To perform disk migration on all the volumes within a group simultaneously, join a destination group (a proxy group) to a group for disk migration (a master group).

For "Join Proxy" procedures see "5.2.3.1 Join."

Swap Slice

Make sure that synchronization copying from the master to the proxy is complete in the Main Screen and then swap slices comprising the master and slices comprising the proxy.

Follow the procedures below.

1. Selecting a destination proxy

Click an icon of a master volume for disk migration on the GDS Configuration Tree in the Main Screen.

To perform disk migration on all the master volumes within a master group, click the master group icon.

Select [View]:[Details]:[Proxy Object] to view all the proxy objects related to the master object selected on the GDS Configuration Tree, in the Object Information Field.

In this field, click an icon of a destination proxy volume (or a proxy group).



Note Possible Proxy Objects for Swapping

"Swap Slices" is possible with proxy objects if they are joined and copy is complete.



Note If There Is a Session by Disk Unit's Copy Function

If there is a session by disk unit's copy function between the master and the proxy, slice swapping fails. For existing sessions, use the `sdxinfo -S -e` long command and check the FUNC field of the results. If the FUNC field for any slice of the master or the proxy shows a value other than the asterisk (*), a session exists between the master and the proxy. In this event, cancel the session with the `sdxproxy Cancel` command to swap the slices. For details, see "D.6 sdxinfo - Display object configuration and status information" and "D.12 sdxproxy - Proxy object operations."

2. **Selecting the [Swap Slice] menu**
 Select [Operation]:[Proxy Operation]:[Swap Slice] in the Main Screen.

Figure: Swap Slice

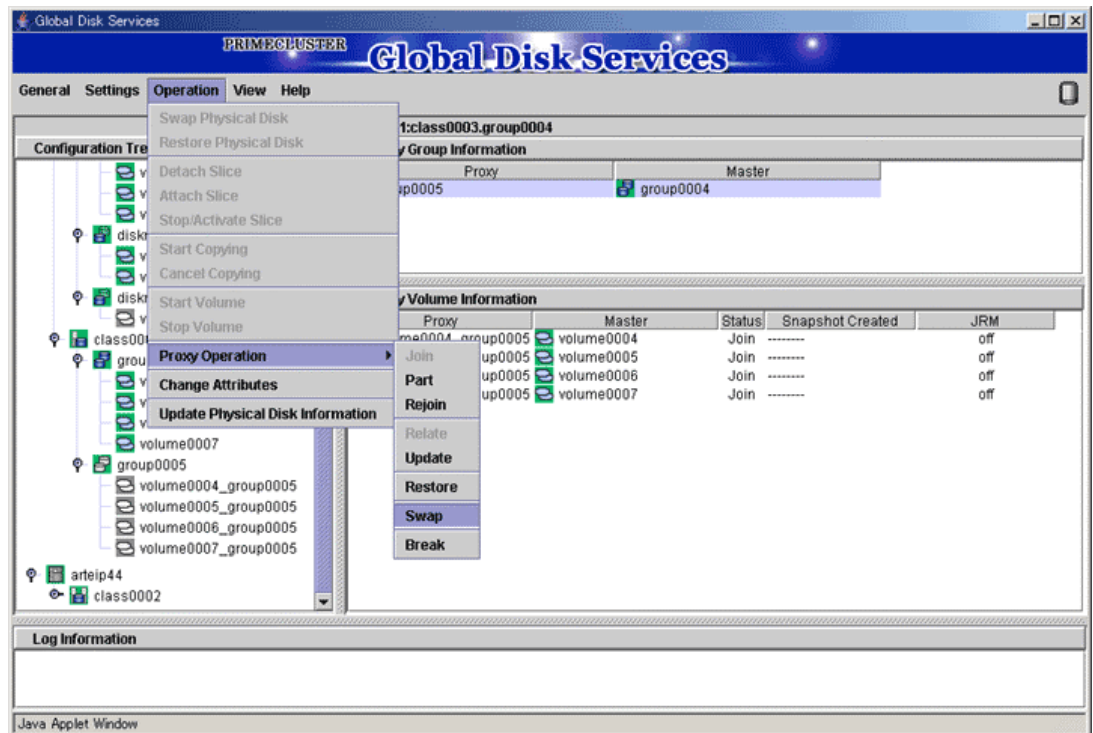

3. **Confirming**
 A confirmation dialog box appears asking you whether to swap the slices.

Figure: Confirming "Swap Slice"

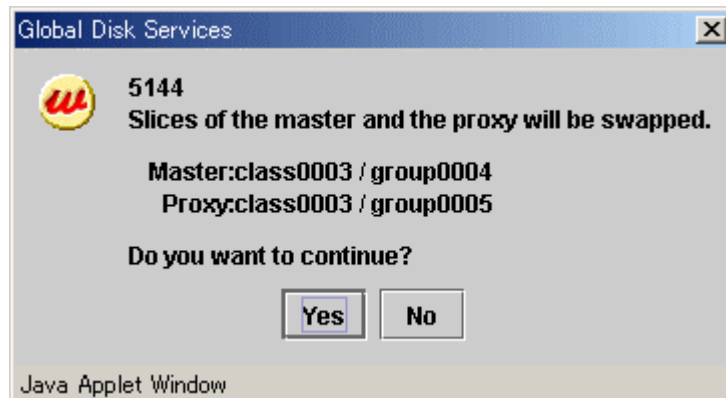

To continue the process, click <Yes>. Clicking <No> cancels the swap process.

4. Information message of the completion

A message window appears informing you that the swap process is complete.

Figure: Information Message of "Swap Slice" Completion

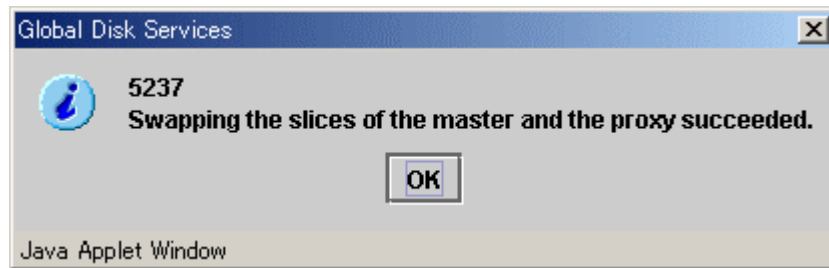

Click <OK> to close the information message window.

Break

Break the relationship between the master and the proxy.

For "Break Proxy" procedures see "5.5.5 Breaking a Proxy."

5.3.6 Copying Operation

The Copying Operation function controls synchronization copying of mirror volumes. GDS provides the following copying operation.

- Start Copying
- Cancel Copying

Start Copying

Synchronization copying will be performed after attaching the slice that is in "invalid" or "copy-stop" status as a result of [Cancel Copying] operation.

For slices in "copy-stop" status, copying will resume from the point where copying was interrupted.

1. Select volume for synchronization copying

In the GDS Configuration tree field or Volume Information field, select the volume you want to copy by clicking the icon.

2. Selecting [Start Copying] menu

In the main screen [Operation] menu, click [Start Copying].

Figure: Start Copying

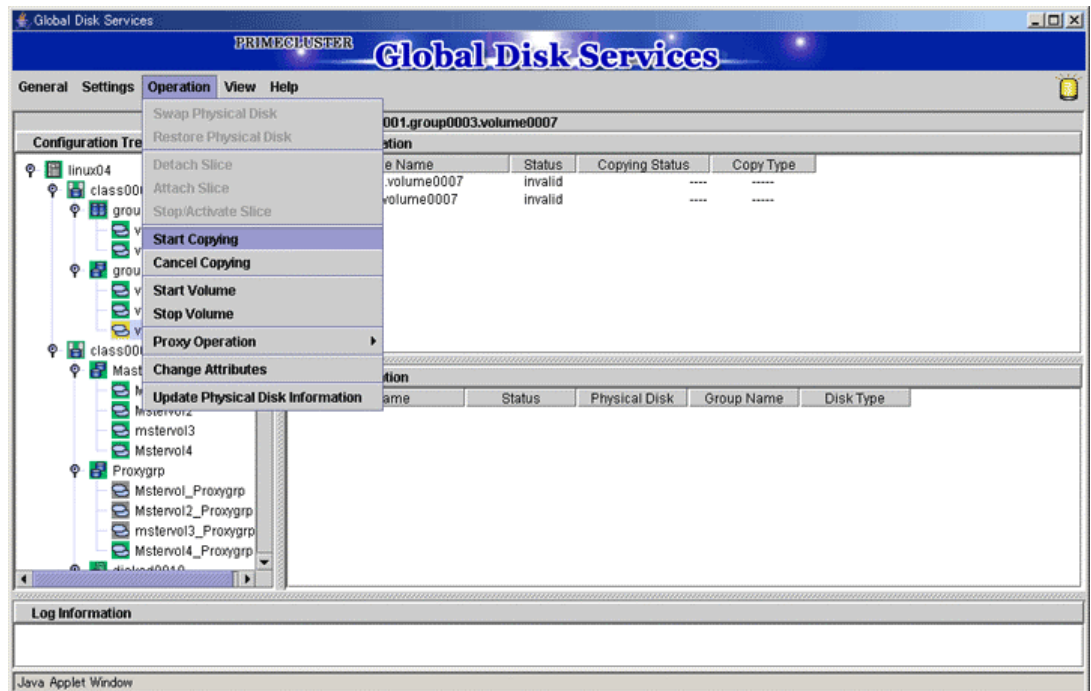

The confirmation screen shown below appears.

To proceed, press <Yes>. Pressing <No> cancels the [Start Copying] process.

Figure: Confirming Start Copying

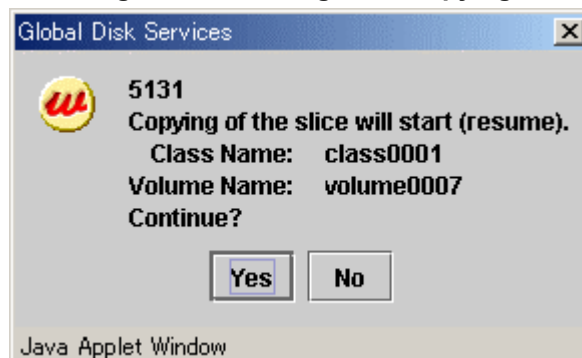

3. [Start Copying] completion screen

Press <OK>, and the message notifying the [Start Copying] completion screen shown below appears.

Figure: Notifying Start Copying Completion

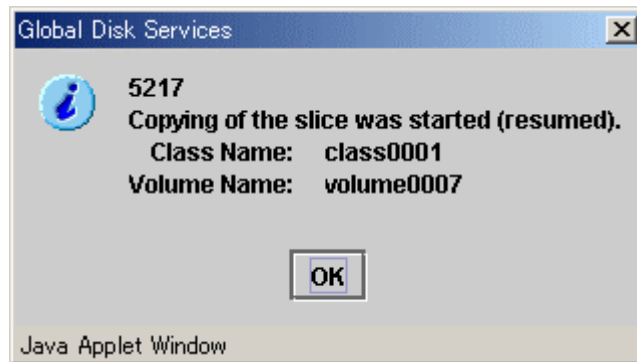

Note [Start Copying] operation unavailable

When more than one volume is selected, [Start Copying] operation cannot be performed.

Cancel Copying

Execution of copying will be stopped to avoid effects caused by accessing the disk in the process of synchronization copying.

The slice whose copying has been stopped will be in "invalid" status. Perform [Start Copying] operation to resume its normal status

1. Select the volume to cancel copying

In the GDS Configuration tree field or Volume Information field, select the volume in "copy" status by clicking the icon.

2. Selecting [Cancel Copying] menu

In the main screen [Operation] menu, click [Cancel Copying].

Figure: Cancel Copying

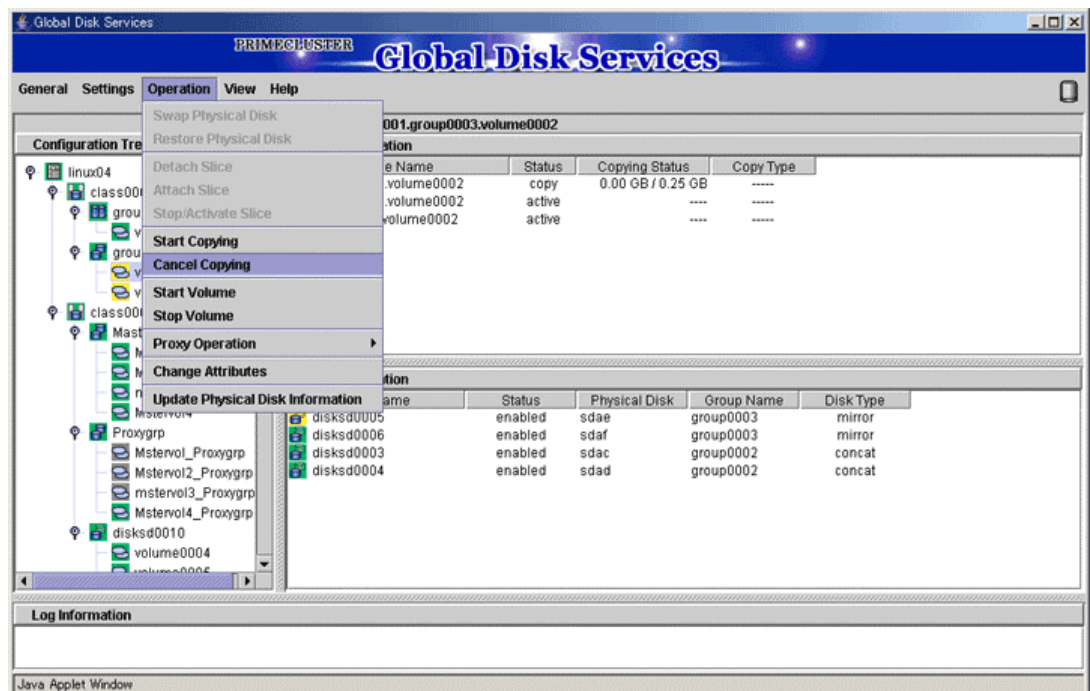

The confirmation screen shown below appears.

To proceed, press <Yes>. Pressing <No> cancels the [Cancel Copying] process.

Figure: Confirming Cancel Copying

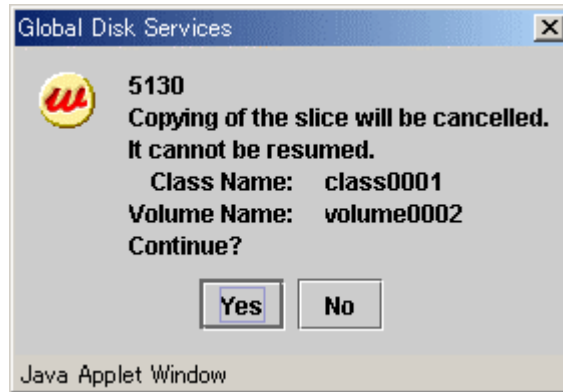

3. [Cancel Copying] completion screen

Press <OK>, and the message notifying the [Cancel Copying] completion screen shown below appears.

Figure: Notifying Cancel Copying Completion

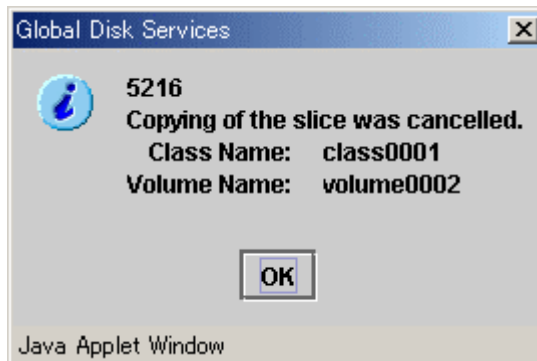

Note

[Cancel Copying] operation unavailable

When more than one volume is selected, [Cancel Copying] operation cannot be performed.

5.4 Changes

Class configurations, group configurations, and volume configurations can be changed through two types of operation: reconfiguration and attribute change. This section explains the changing procedures for each configuration.

5.4.1 Class Configuration

The procedures for changing class configuration are explained below.

Changing Class Configuration

1. Displaying Class Configuration screen

In the main screen [Settings] menu, click [Class Configuration]. Class Configuration screen appears.

Figure: Class Configuration

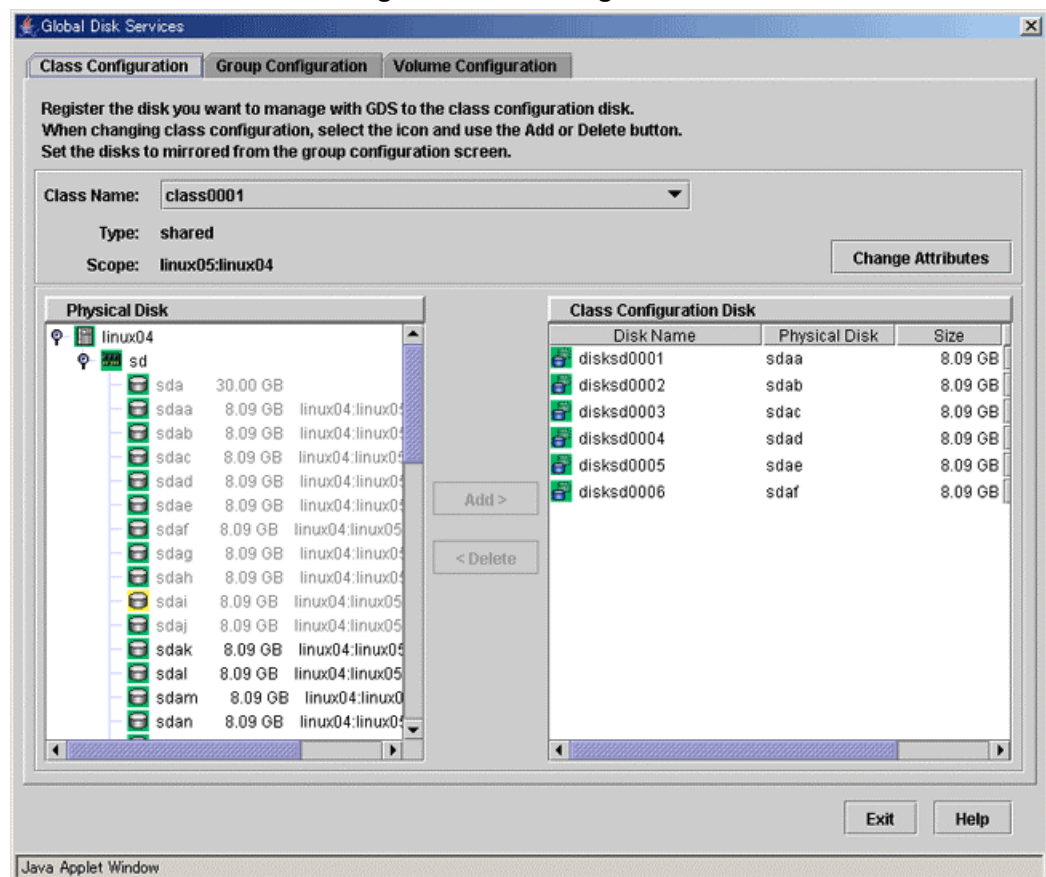

2. Selecting class to change

Select the class you want to change from Class Configuration screen "Class Name."

3. Changing configuration

Follow the procedures below to register a physical disk (create a disk), or to remove a disk.

a) Registering a physical disk (Creating a disk)

1. Select the physical disk you want to register as disk from [Physical Disk] field.

2. Press <Add>.

3. When changing the default disk attributes, change the disk type by selecting the appropriate disk from the [Class Configuration Disk/Group] field.

Figure: Physical Disk Registration

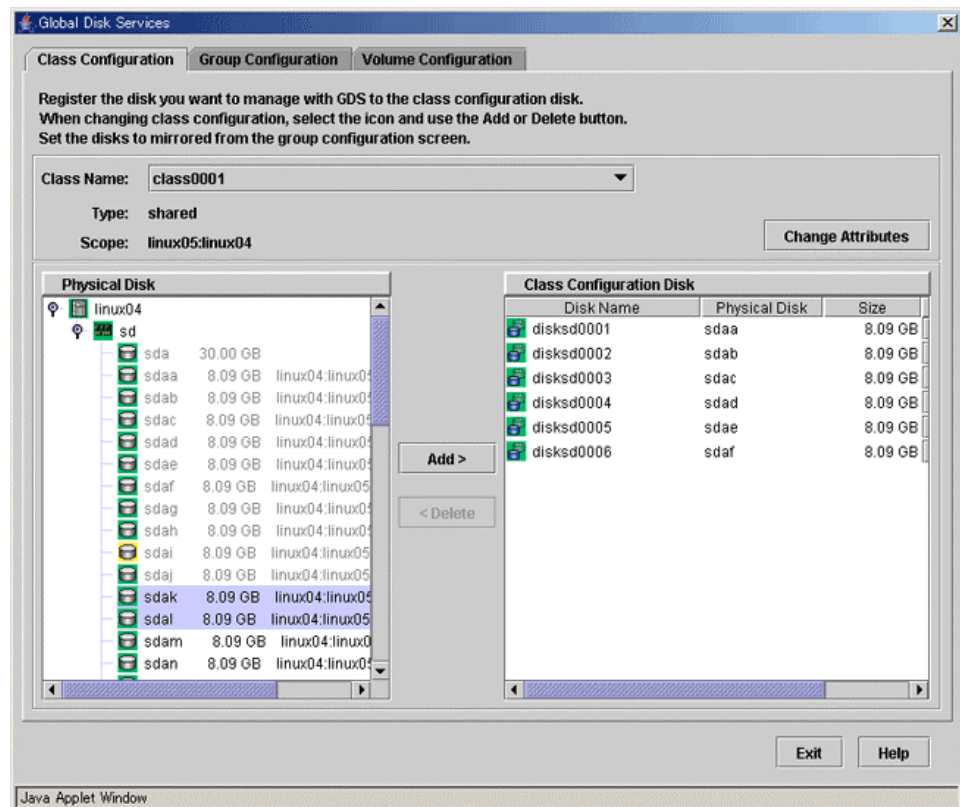

- b) Removing a disk
 1. Select the disk you want to remove from the [Class Configuration Disk/Group] field.
 2. Press <Delete>.

4. Completing the change

If you have no other changes to make, press <Exit>.

Changing the Class Attributes

When changing the disk class attributes, there are two procedures to choose from:

- using main screen Operation menu
- using Change Attributes button in the Class Configuration screen

Using main screen Operation menu

1. Selecting class to change

Display the class you want to change in the main screen Configuration Tree field. Click the icon and select the class you want to change.

2. Displaying Class Attributes Definition screen

In the main screen [Operation] menu, click [Change Attributes]. Class Attributes Definition screen appears.

Figure: Class Attributes Definition Screen

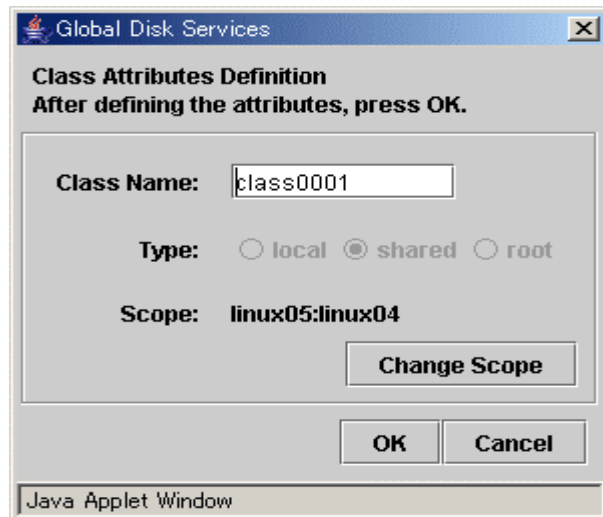

3. Changing attributes

You can change the following attributes:

- Class Name
- Scope



[See](#)

For information on assigning a class name, see “A.1.1 Object Name.”

4. Implementing changes

Press <OK> to implement the attributes change, or <Cancel> to cancel.

Using Change Attributes button in the Class Configuration screen

1. Displaying Class Attributes Definition screen

Press <Change Attributes> and Class Attributes Definition screen appears.

2. Changing attributes

You can change the following attributes:

- Class Name
- Scope



[See](#)

For information on assigning a class name, see “A.1.1 Object Name.”

3. Implementing changes

Press <OK> to implement the attributes change, or <Cancel> to cancel.



Note Changes in Special File Path Name

Changing the class name will also change the special file path name used to access the volume.

Changing the Disk Attributes

When changing the disk attributes, there are two procedures to choose from:

- Using main screen Operation menu.
- Using the Class Configuration Setting screen.

Using main screen Operation menu

1. Selecting disk to change

Display the disk you want to change in the main screen [Disk Information] field. Click the icon and select the disk you want to change.

2. Displaying Disk Attributes Definition screen

In the main screen [Operation] menu, click [Change Attributes]. Disk Attributes Definition screen appears.

Figure: Disk Attribute Definition Screen

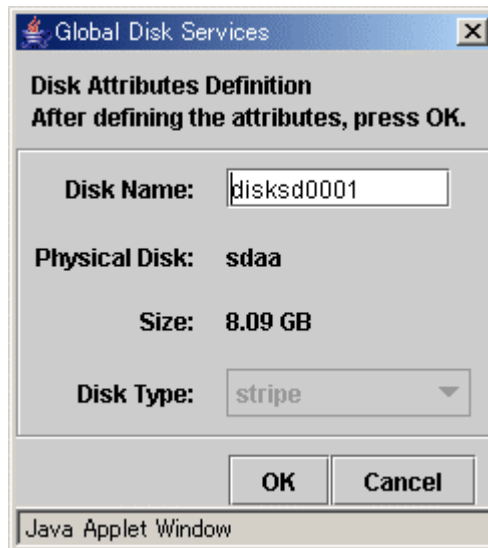

3. Changing attributes

You can change the following attributes.

- Disk Name
- Disk Type



See

For details about assigning a disk name, see "A.1.1 Object Name."

4. Implementing changes

Press <OK> to implement the attributes change, or <Cancel> to cancel.

Using the Class Configuration Setting screen

1. Displaying the disk to change attributes

Select the disk of which you want to change attributes in the [Class Configuration Disk/Group] field.

2. Changing attributes

You can change the following attributes.

- Disk Name
- Disk Type



See

For details about assigning a disk name, see "A.1.1 Object Name."

3. Implementing changes

Press <OK> to implement the attributes change, or <Cancel> to cancel.

5.4.2 Group Configuration

The procedures for changing group are explained below.

1. Displaying Group Configuration screen

In the main screen [Settings] menu, click [Group Configuration]. Group Configuration screen appears.

Figure: Group Configuration

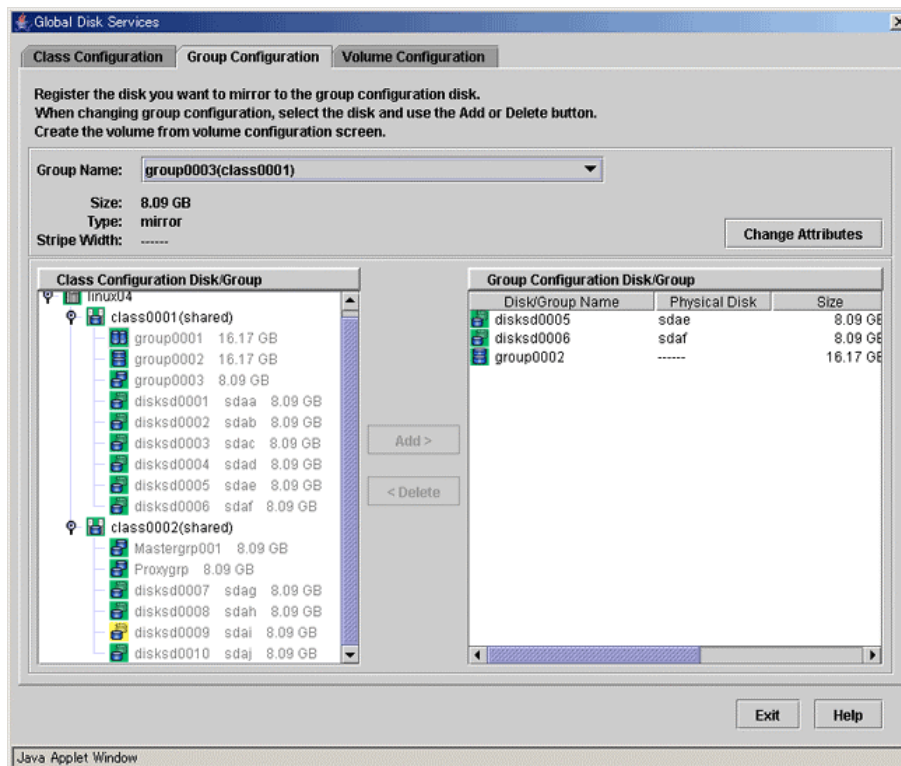

2. Selecting group to change

Select the group you want to change from Group Configuration screen “Group Name.”

3. Changing configuration

Follow the procedures below to connect a disk/lower level group to a group, or to disconnect a disk/lower level group from a group.

- a) Connecting a disk/lower level group
 - 1- Select the disk/lower level group you want to add to group from [Class Configuration Disk/Group] field.
 - 2- Press <Add>.

Figure: Connecting disk/lower level group

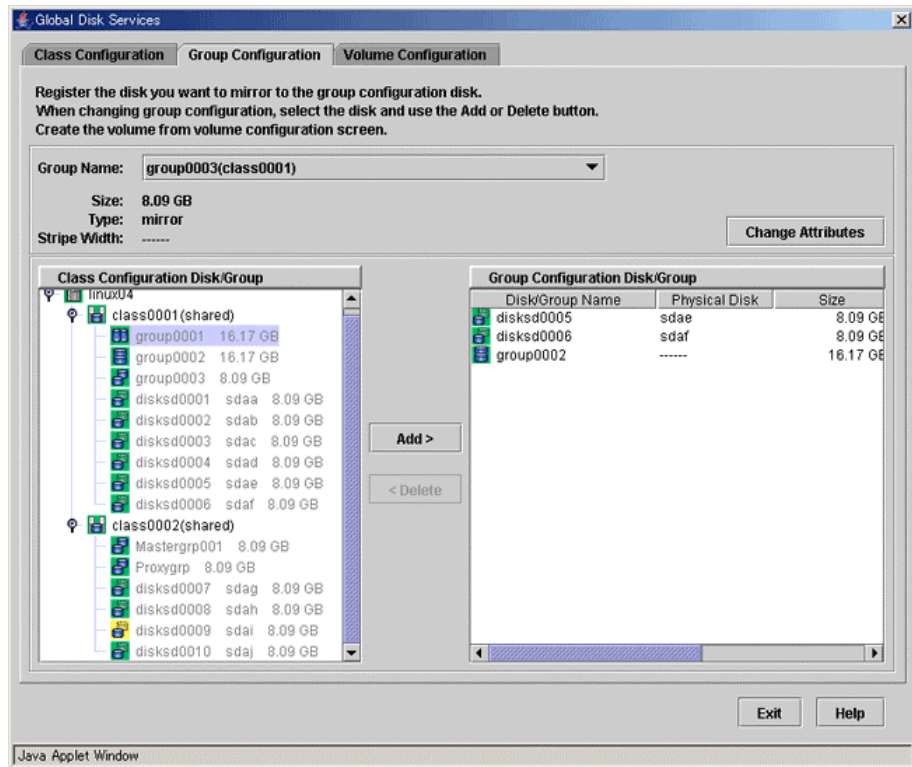

- b) Disconnecting a disk/lower level group
- 1- Select the disk/lower level group you want to disconnect from [Group Configuration Disk/Group] field.
 - 2- Press <Delete>.

4. Completing the change

If you have no other changes to make, press <Exit>.

Changing Group Attributes

You can only change “group name.”

When changing the group attributes, there are two procedures to choose from:

- using main screen [Operation] menu
- using <Change Attributes> button in the [Group Configuration] screen

Using main screen Operation menu

1. Selecting group to change

Display the group you want to change in the main screen Configuration Tree field. Click the icon and select the group you want to change.

2. Displaying Group Attributes Definition screen

In the main screen [Operation] menu, click [Change Attributes]. [Group Attributes Definition] screen appears.

Figure: Group Attributes Definition Screen



3. Changing group name

You can only change the group name.
Press <OK> to implement the change, or <Cancel> to cancel.



See

For information on assigning a group name, see "A.1.1 Object Name."

Using Change Attributes button in the Group Configuration screen

1. Displaying Group Attributes Definition screen

Press <Change Attributes>, and [Group Attributes Definition] screen appears.

2. Changing group name

Change the group name.
Press <OK> to implement the change, or <Cancel> to cancel.



See

For information on assigning a group name, see "A.1.1 Object Name."

5.4.3 Volume Configuration

The procedures for changing volume configuration are explained below.

Changing Volume Configuration

1. Selecting volume to change

Display the you want to change in the main screen Configuration Tree field. Click the icon and select the volume you want to change.

2. Displaying Volume Attributes Definition screen

In the main screen [Operation] menu, click [Change Attributes]. [Volume Attributes Definition] screen appears.

Figure: Volume Attributes Definition Screen

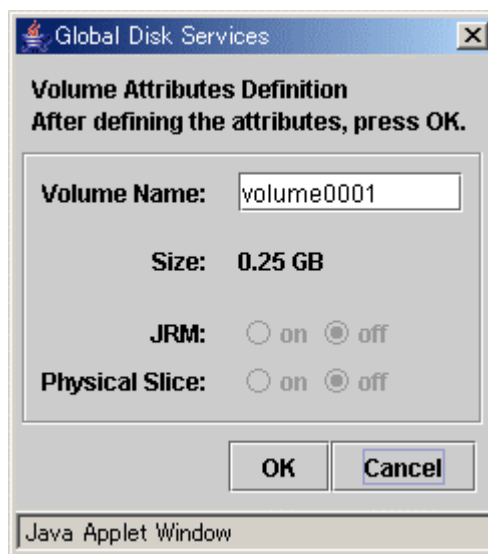

3. Changing attributes

You can change the following attributes:

- Volume Name
- JRM (on/off)
- Physical Slice (on/off)



See

For information on assigning a volume name, see "A.1.1 Object Name."

4. Implementing changes

Press <OK> to implement the attributes change, or <Cancel> to cancel.



Note Changes in Special File Path Name

Changing the volume name will also change the special file path name used to access the volume.

5.5 Removals

This section explains procedures to remove file system, volume, group, and class.

When file system is not created, you can start the unmirroring process from removing the volume.

5.5.1 Removing a File System

The procedures for removing a file system are explained below.

1. Displaying the File System Configuration screen

In the main screen [Settings] menu, click [File System Configuration]. File System Configuration screen appears.

2. Selecting group/disk

In the Group/Disk List, select a group or disk with which you want to perform an operation.

3. Removing file system

Select the volume from which you want to remove the file system, and press <Delete>.

When removing more than one file system, select the next volume, and repeat the same process.

Figure: Removing File System

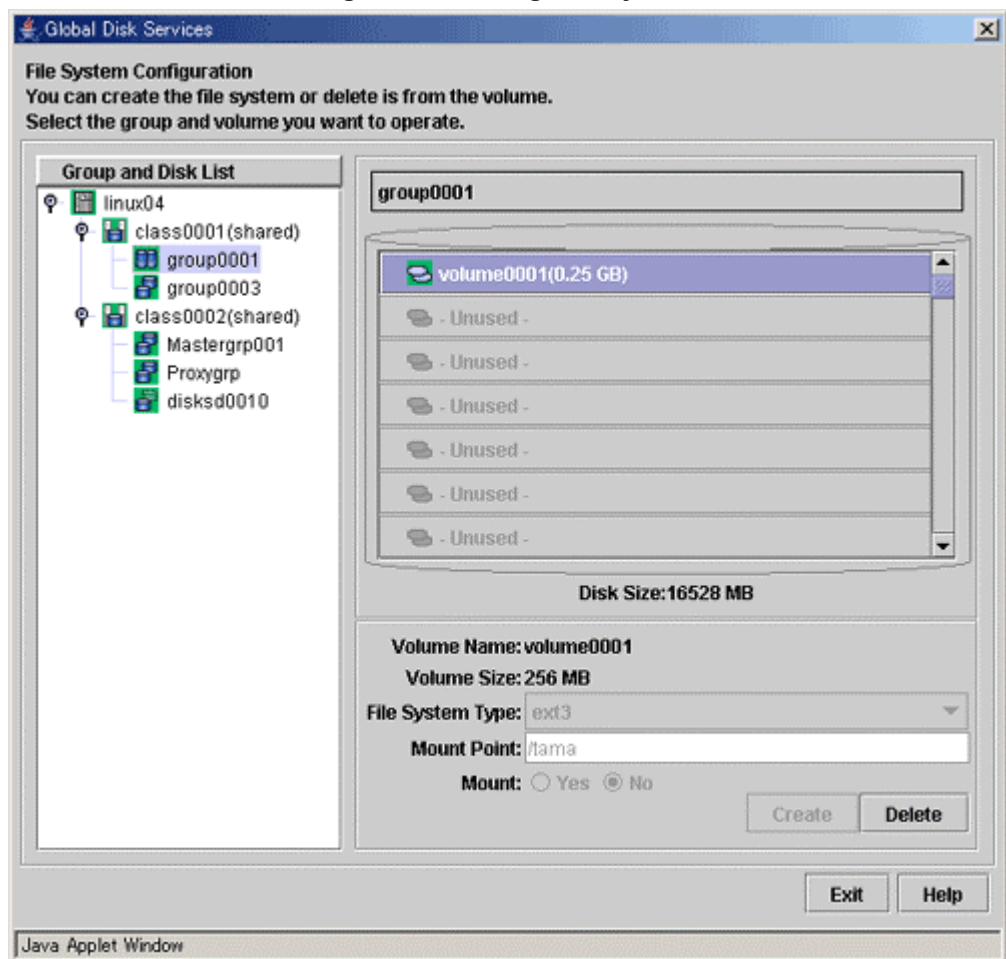

5.5.2 Removing a Volume

The procedures for removing a mirror volume are explained below.

1. Confirming the volume status

A volume containing a temporarily detached slice cannot be removed. When there is a temporarily detached slice, you must attach the slice before removing the volume. Volume status can be confirmed in the main screen.

Figure: Displaying Volume Information

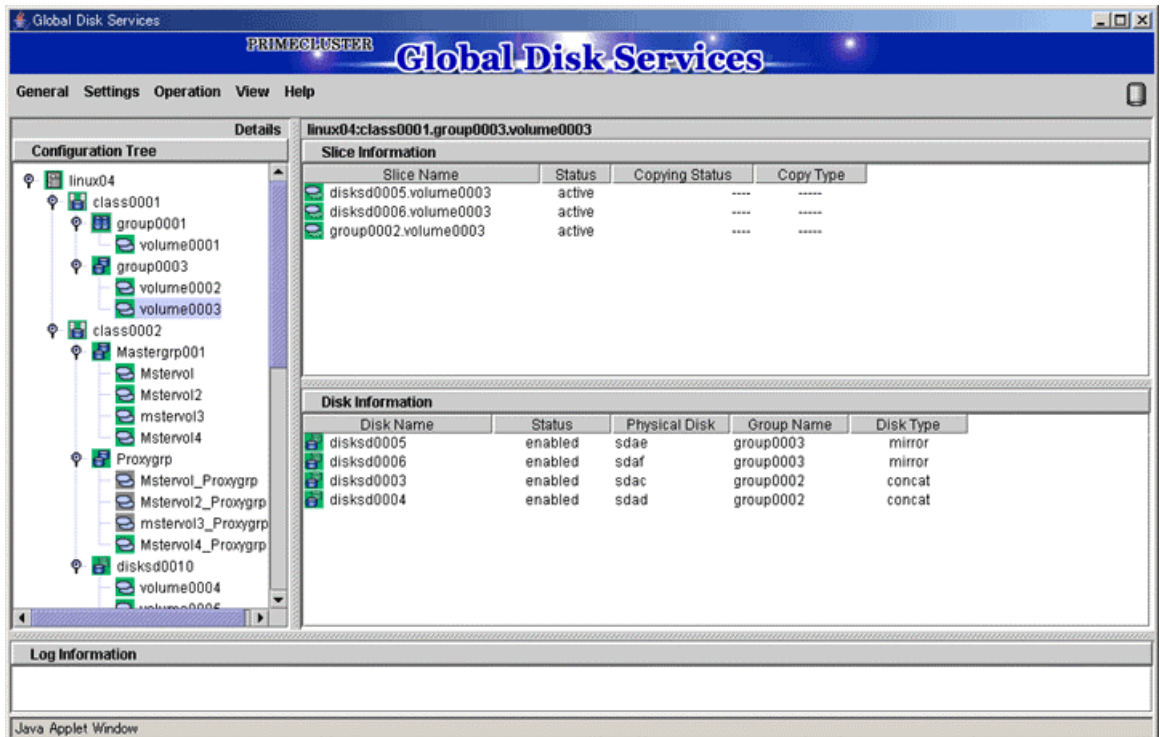

2. Attaching a temporarily detached slice

When there is a temporarily detached slice, go to [Operation] menu and click [Attach Slice]. The detached slice will be attached again. For information on Attach Slice operation, see “5.3.2.1 Backup (by Slice Detachment).”

3. Removing volume

The procedures for removing a volume are explained below.

(1) Displaying the Volume Configuration screen

In the main screen [Settings] menu, click [Volume Configuration]. Volume Configuration screen appears.

(2) Removing a volume

Select the volume you want to remove, and press <Delete>.

When removing more than one volume, select the next volume, and repeat the same process.

Figure: Removing Volume

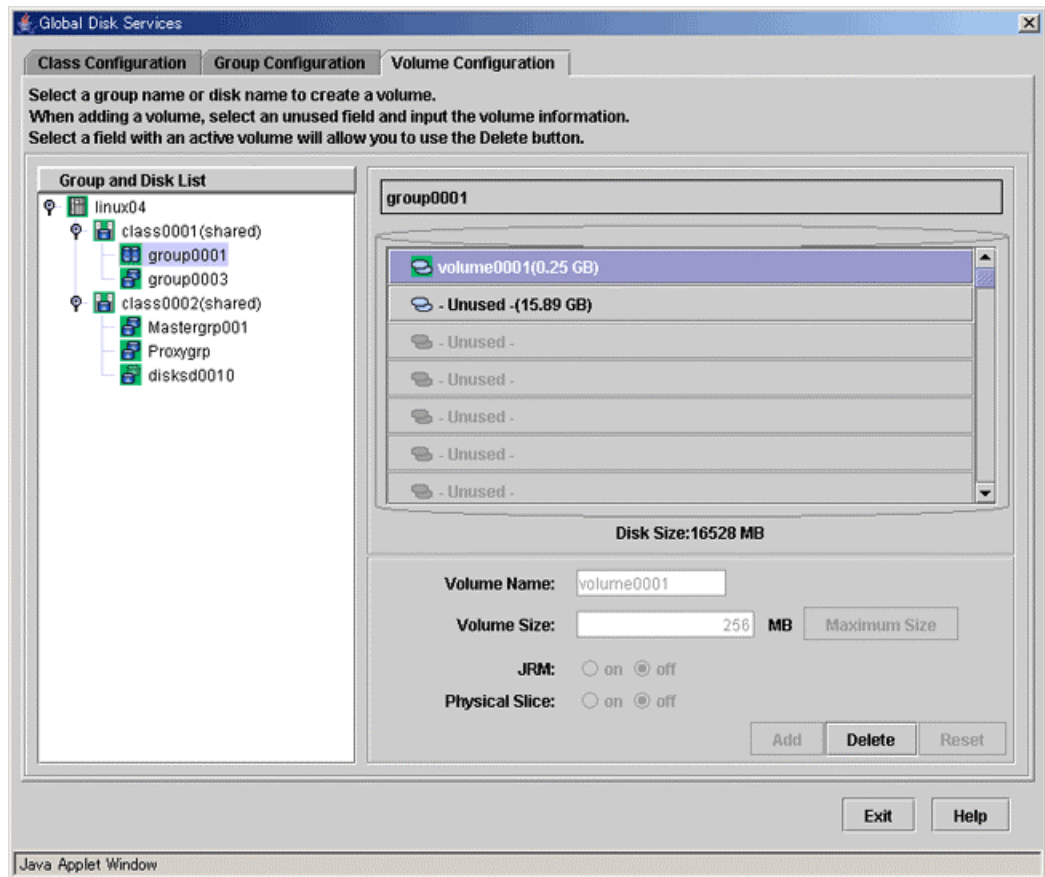

5.5.3 Removing a Group

Disconnecting all disks/lower level groups registered with a group will automatically remove the group. The procedures are explained below.

1. Removing all volumes within the group

If there is even a single volume, you cannot remove the group.

Remove all volumes within the group by following the procedures described in “5.5.2 Removing a Volume.”

2. Disconnecting disks/lower level groups from group

Disconnect all disks/lower level groups by following the procedures below.

(1) Displaying Group Configuration screen

In the main screen [Settings] menu, click [Group Configuration]. [Group Configuration] screen appears.

(2) Selecting group to remove

Select the group you want to remove from [Group Configuration] screen “Group Name” field.

(3) Disconnecting disk/lower level group

Select the disk/lower level group you want to remove from [Group Configuration Disk/Group] field, and press <Delete>.

Figure: Disconnecting Disk/Lower level group

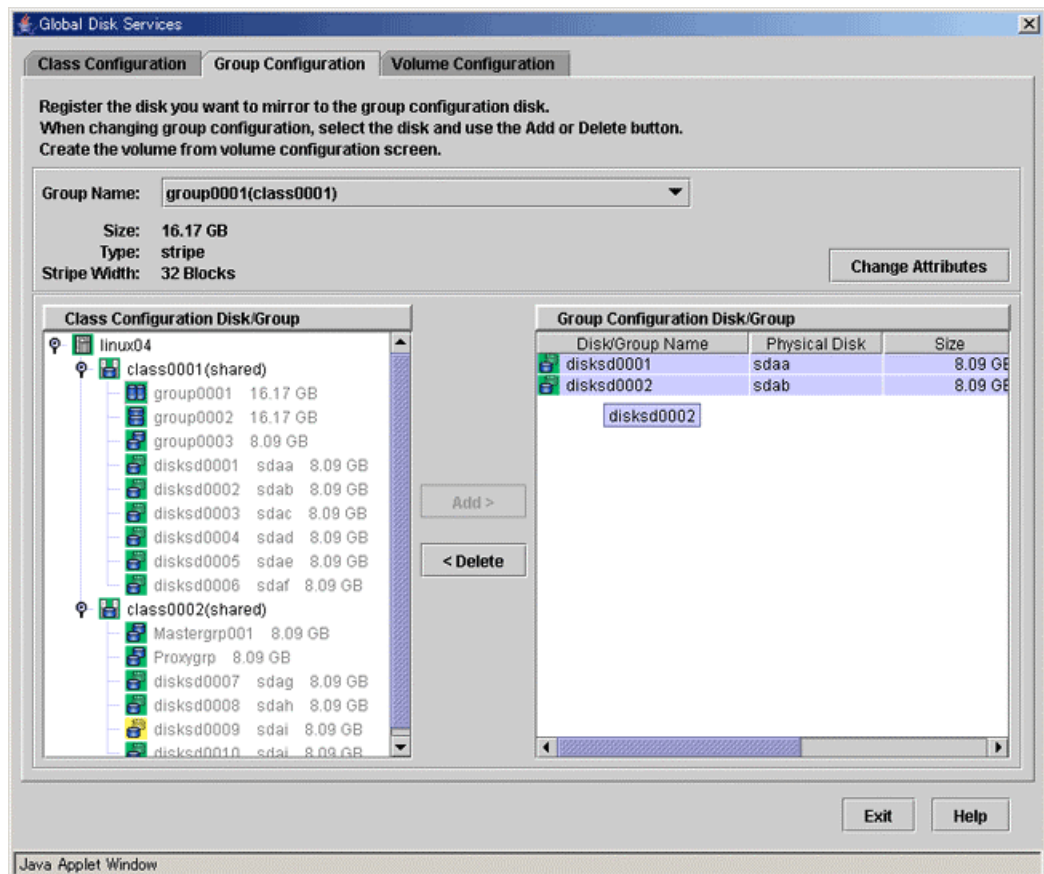

5.5.4 Removing a Class

Removing all disks within a class will automatically remove the class.
The procedure is explained below.

1. Removing all groups within the class

Remove all groups within the class by following the procedure described in “5.5.3 Removing a Group.”

2. Removing all disks from class

Disconnect all disks by following the procedure below.

(1) Displaying Class Configuration screen

In the main screen [Settings] menu, select [Class Configuration]. The Class Configuration screen appears.

(2) Selecting class to remove

Select the class you want to remove from Class Configuration screen “Class Name” field.

(3) Removing disk

Select the disk you want to remove from [Class Configuration Disk] field, and click <Delete>.

Figure: Removing Disk

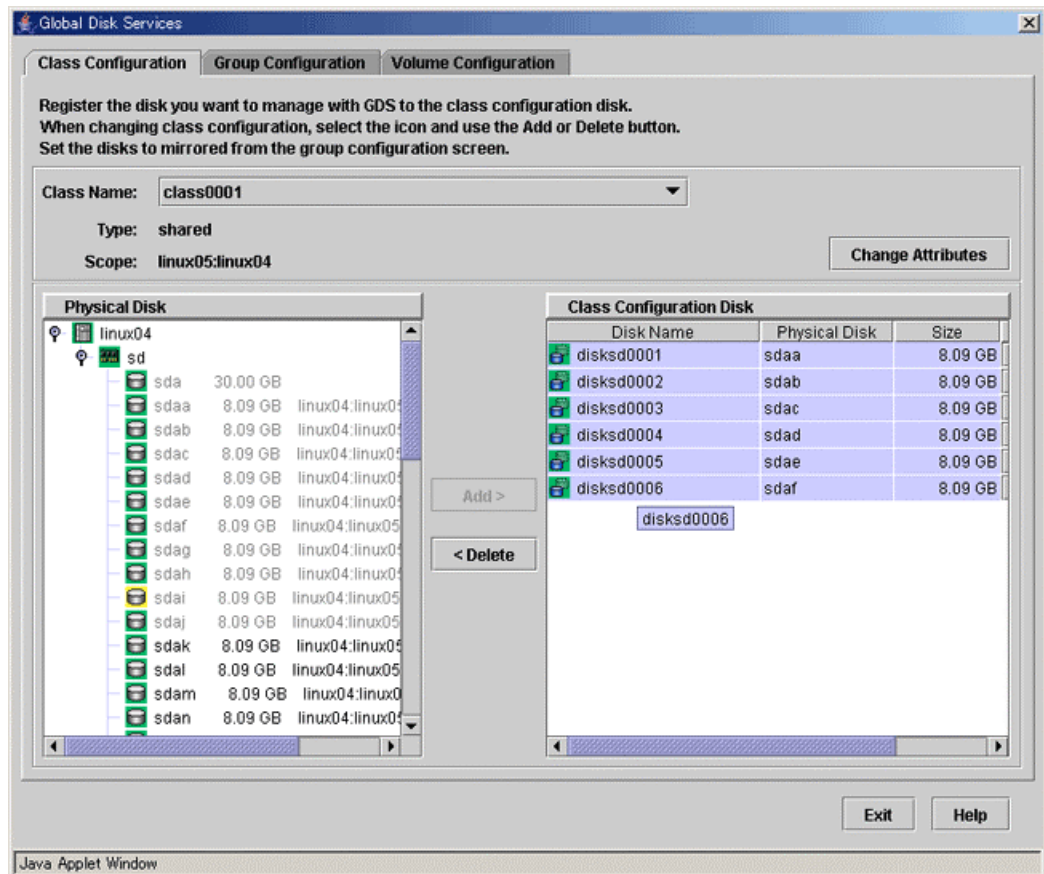

5.5.5 Breaking a Proxy

This subsection describes the procedures for breaking the relationships between masters and proxies in GDS Snapshot installed systems.

- 1. Selecting a master for break**
Click an icon of a master object for break on the GDS Configuration Tree in the Main Screen.
- 2. Selecting a proxy for break**
Select [view]:[Details]:[Proxy Object] to view all the proxy objects related to the master selected on the GDS Configuration Tree, in the Object Information Field. In this field, click an icon of a proxy object for break.
- 3. Selecting the [Break] menu**
Select [Operation]:[Proxy Operation]:[Break] in the Main Screen.

Figure: Break

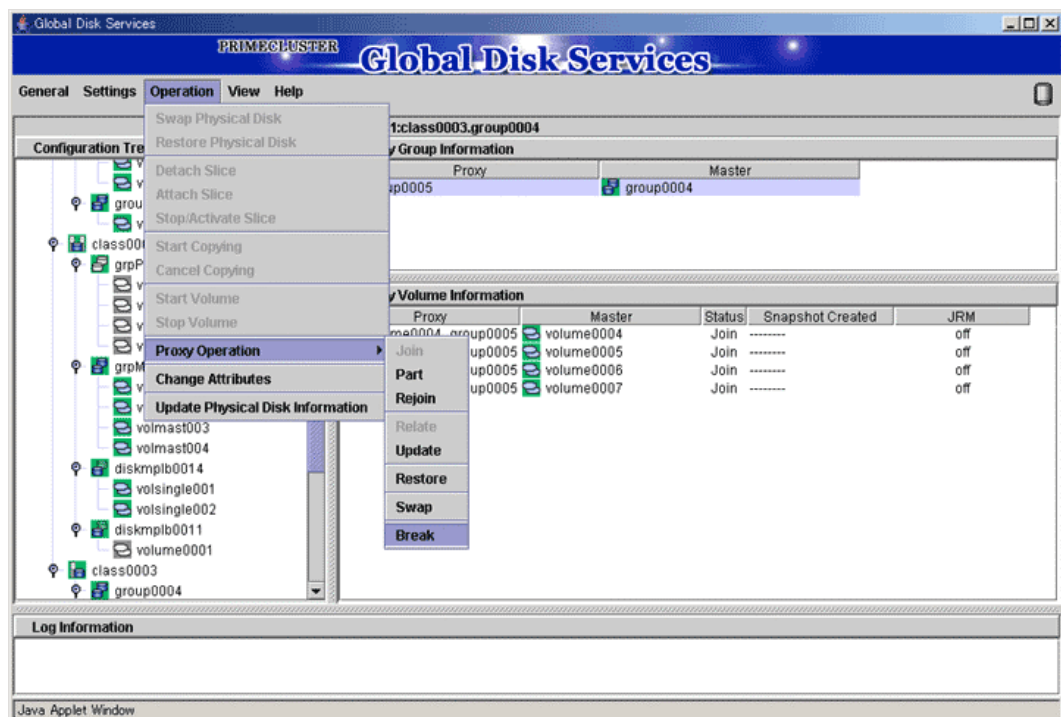

- 4. Confirming**
A confirmation dialog box appears asking you whether to break the proxy.

Figure: Confirming "Break"

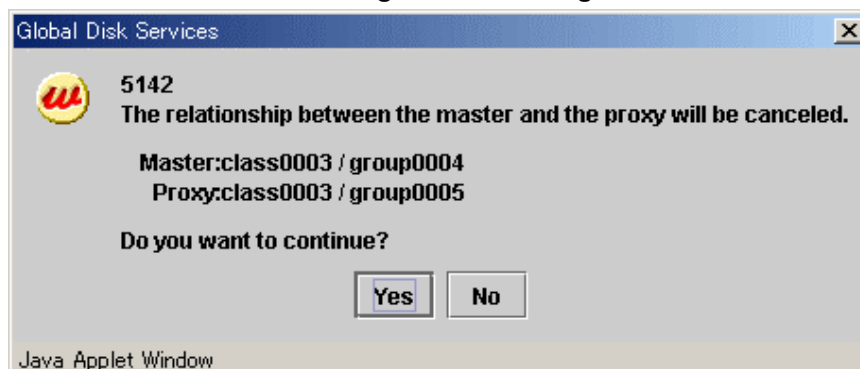

To continue the process, click <Yes>. Clicking <No> cancels the break process.

5. Information message of the completion

A message window appears informing you that the break process is complete.

Figure: Information Message of "Break" Completion]

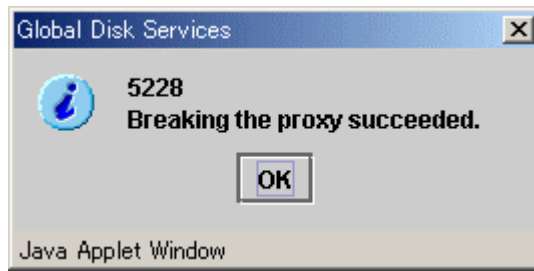

Click <OK> to close the information message window.

Chapter 6 Backing Up and Restoring

The GDS mirroring function secures data from disk failures by preserving replicas of data on multiple disks. However, the mirroring function is not capable of protecting data against accidental erasure by the user or data crash due to an application malfunction. In addition, data can be lost due to multiple disk breakdown or large-scale disaster. To recover data when these troubles occur, data back up is mandatory. Be sure to back up data on a regular basis.

This chapter discusses the operating procedures for backing up and restoring GDS volumes to provide useful information concerning operational design for backup and restore.

6.1 Backing Up and Restoring Shared Disks

This section discusses the method of backing up and restoring shared disks in a system where GDS Snapshot has not been implemented.

The following is an example of backing up and restoring volume Volume1 in class Class1.

6.1.1 Offline Backup

1) Stopping the services

1a) With a shared volume used in a cluster application

1a-1) Exit all cluster applications.

1a-2) Activate the volume on a node on which backup is conducted.

```
# sdxvolume -N -c Class1 -v Volume1
```

1b) With a volume not used by a cluster application

1b-1) Stop the services using the volume.

1b-2) When the volume is used as a file system, unmount the file system. The following shows an example when the mount point is /mnt1.

```
# cd /  
# umount /mnt1
```

2) Backing Up

Back up volume data. The following shows an example of backing up data to a tape medium of tape device /dev/st0.



See

For details about the backup method, see manuals of a file system to be backed up and used commands.

- When backing up data held in a raw device with the dd(1) command

```
# dd if=/dev/sfdsk/Class1/rdisk/Volume1 of=/dev/st0 bs=32768
```

3) Resuming the services

3a) With a shared volume used in a cluster application

3a-1) Inactivate the volume on the node where backup was conducted.

```
# sdxvolume -F -c Class1 -v Volume1
```

3a-2) Launch cluster applications.

3b) With a volume not used by a cluster application

3b-1) When the volume is used as a file system, mount the file system. The following shows examples when the mount point is /mnt1.

- For a ext3 file system

```
# mount -t ext3 /dev/sfdsk/Class1/dsk/Volume1 /mnt1
```

3b-2) Resume the services.

6.1.2 Online Backup (by Slice Detachment)

For mirror volumes, data can be backed up using snapshots by detaching slices during the services operation.



See

For use conditions on snapshots by detaching a slice, see "A.2.8 Creating a Snapshot by Detaching Slice."

To secure consistency of data in a detached slice, the services must be stopped temporarily when detaching the slice.



See

For securing consistency of snapshot data, see "A.2.15 Ensuring Integrity of Snapshot Data."

1) Stop the services

1a) With a shared volume used by a cluster application, exit the cluster application.

1b) With a volume not used by a cluster application

1b-1) Stop the services using the volume.

1b-2) When the volume is used as a file system, unmount the file system. The following shows an example when the mount point is /mnt1.

```
# cd /  
# umount /mnt1
```

2) Detaching the slice

Detach the slice from the mirror volume. The following shows an example of detaching the slice from disk Disk1.

```
# sdxslice -M -c Class1 -d Disk1 -v Volume1
```



See

When using GDS Management View, see "Slice Detachment" in "5.3.2.1 Backup (by Slice Detachment)."

3) Resuming the services

3a) With a shared volume used by a cluster application, execute the cluster application.

3b) With a volume not used by a cluster application

3b-1) When the volume is used as a file system, mount the file system. The following shows an example when the mount point is /mnt1.

- For a ext3 file system

```
# mount -t ext3 /dev/sfdsk/Class1/dsk/Volume1 /mnt1
```

3b-2) Resume the services.

4) When the volume is used as a file system, check and repair consistency of the file system. If the file system was unmounted when the slice was detached in step 1), this step can be skipped.

- For a ext3 file system

```
# fsck -t ext3 -y /dev/sfdsk/Class1/dsk/Disk1.Volume1
```

5) Backing Up

Back up data in the detached slice. The following shows an examples of backing up data to a tape medium of tape device /dev/st0.



For details about the backup method, see manuals of a file system to be backed up and used commands.

- When backing up data held in a raw device with the dd(1) command

```
# dd if=/dev/sfdsk/Class1/rdsk/Disk1.Volume1 of=/dev/st0 bs=32768
```

6) Re-attaching the slice

Re-attach the detached slice to the mirror volume.

```
# sdxslice -R -c Class1 -d Disk1 -v Volume1
```



When using GDS Management View, see "Attach Slice" in "5.3.2.1 Backup(by Slice Detachment)."

6.1.3 Restoring

1) Stopping the services

1a) With a shared volume used by a cluster application, exit the cluster application.

1b) With a volume not used by a cluster application

1b-1) Stop the services using the volume.

1b-2) When the volume is used as a file system, unmount the file system. The following shows an example when the mount point is /mnt1.

```
# cd /  
# umount /mnt1
```

2) Restoring

Restore the volume data. The following shows an example of restoring data from a tape medium of tape device /dev/st0.



For details about the restore method, see manuals of a file system to be restored and used commands.

- When restoring data held in a raw device with the dd(1) command

```
# dd if=/dev/st0 of=/dev/sfdsk/Class1/rdsk/Volume1 bs=32768
```

3) Resuming the services

3a) With a shared volume used by a cluster application, execute the cluster application.

3b) With a volume not used by a cluster application

3b-1) When the volume is used as a file system, mount the file system. The following shows an example when the mount point is /mnt1.

- For a ext3 system

```
# mount -t ext3 /dev/sfdsk/Class1/dsk/Volume1 /mnt1
```

3b-2) Resume the services.

6.2 Online Backup and Instant Restore through Proxy Volume

This subsection describes the procedures for online backup and instant restore of shared volumes through use of snapshots by GDS Snapshot proxy volumes.

There are two online backup methods: one uses the function as "1.5.1 Snapshot by Synchronization" and the other uses the function as "1.5.3 Instant Snapshot by OPC." By cooperation with the Advanced Copy function (EC or OPC) of the Fujitsu Storage Systems ETERNUS, backup and restore processing that does not impose the load on the server or SAN becomes possible.

The following table shows backup and restore methods and their features.

Operation	Disk Unit Copy Function	Master Configuration (*1)	Proxy Configuration (*1)	Feature
Backup(Sync)	-	single mirror stripe concat	single mirror stripe concat	<ul style="list-style-type: none"> With synchronized masters and proxies, snapshots are created simply by parting the proxies. By use of the JRM for proxies, high-speed resynchronization is executable for snapshot re-creation. Striping and concatenating masters are possible. Mirroring, striping and concatenating proxies are possible.
	EC REC	single mirror	single	<ul style="list-style-type: none"> With synchronized masters and proxies, snapshots are created simply by parting the proxies. By use of a disk unit's copy function, snapshot creation that does not impose the load on the server or SAN is possible. By use of a disk unit's incremental copy function, high-speed resynchronization that does not impose the load on the server or the SAN is performed for snapshot re-creation.
	OPC ROPC	single mirror	single	<ul style="list-style-type: none"> With synchronized masters and proxies, snapshots are created simply by parting the proxies. By use of a disk unit's copy function, snapshot creation that does not impose the load on the server or SAN is possible.
Backup(OPC)	OPC ROPC	single mirror	single	<ul style="list-style-type: none"> There is no need to synchronize masters and proxies before creating snapshots, and backups can be created any time without scheduling in advance. By use of a disk unit's copy function, snapshot creation that does not impose the load on the server or SAN is possible.

Operation	Disk Unit Copy Function	Master Configuration (*1)	Proxy Configuration (*1)	Feature
Restore	-	single mirror stripe concat	single mirror stripe concat	<ul style="list-style-type: none"> By use of the JRM for proxies, high-speed restore is possible. Striping and concatenating masters are possible. Striping and concatenating proxies are possible.
	OPC ROPC	single mirror	single mirror	<ul style="list-style-type: none"> By use of a disk unit's copy function, restore that does not impose the server or SAN is possible.

(*1) In the table above, configurations indicate objects as follows.

Configuration	Description
single	This configuration means any one of the following objects. <ul style="list-style-type: none"> A single volume created in a single disk A mirror group not hierarchized, with the multiplicity of one A volume created in a mirror group not hierarchized, with the multiplicity of one
mirror	This configuration means either the following objects. <ul style="list-style-type: none"> A mirror group not hierarchized, with the multiplicity of two and higher A mirror volume created in a mirror group not hierarchized, with the multiplicity of two and higher
stripe	This configuration means either the following objects. <ul style="list-style-type: none"> A mirror group to which one or more stripe groups are connected A volume created in a mirror group to which one or more stripe groups are connected
concat	This configuration means either the following objects. <ul style="list-style-type: none"> A mirror group to which one or more concatenation groups are connected A volume created in a mirror group to which one or more concatenation groups are connected

For details about backup and restore by cooperation with copy functions of disk units (EC, OPC), see "1.5.2 Snapshot Function with No Load to the server/SAN," "A.2.13 Using the Advanced Copy Function in a Proxy Configuration," and "A.2.14 Instant Snapshot by OPC."

6.2.1 Online Backup (by Synchronization)

In a system employing GDS Snapshot, backups can be created using snapshots from proxy volumes during the services operation.

However, to secure consistency of snapshot data, the services must be stopped temporarily when creating a snapshot (when parting a proxy volume from a master volume).



See

For securing consistency of snapshot data, see "A.2.15 Ensuring Integrity of Snapshot Data."

Figure: Backup Schedule

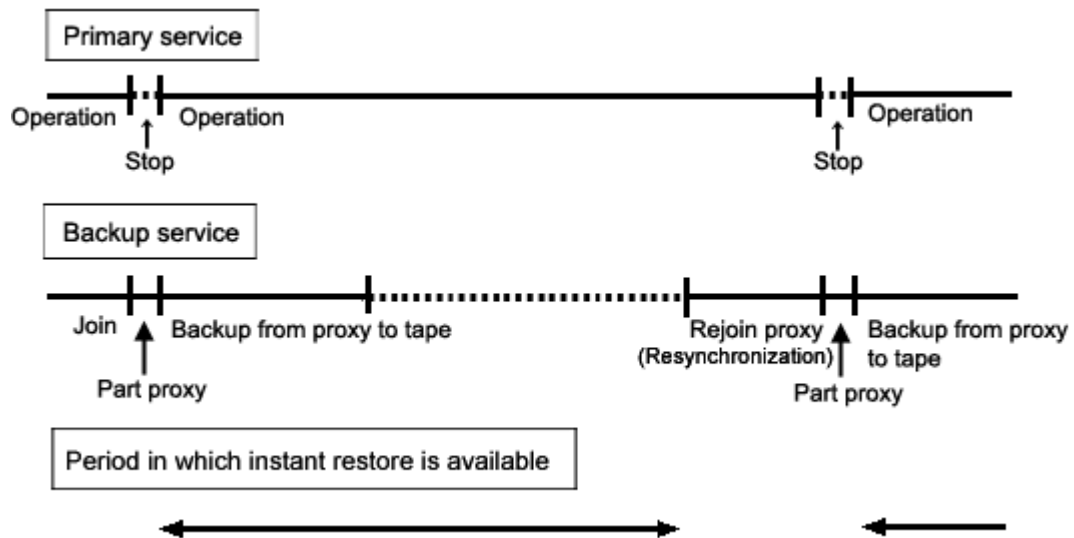

Note Instant Restore

If an error occurs in master volume data while the master volume and a proxy volume are joined, the same error occurs in data of the proxy volume and instant restore becomes unavailable. If this happens, you must restore data from tape. After you execute online backup by parting a proxy volume, you are recommended to leave the proxy volume parted until just before re-executing online backup.



Note Snapshot through Disk Unit Copy Functions

If groups are hierarchized, or if proxies are in mirroring configuration with the multiplicity of two and higher, copy functions of disk units are unavailable for copying data from masters to proxies. For details, see "A.2.13 Using the Advanced Copy Function in a Proxy Configuration."

Procedure

1) Joining a proxy volume

To prepare for creating a snapshot, relate and join proxy volume Volume2 as the copy destination of master volume Volume1 to the master volume. This example shows the procedure when Volume1 and Volume2 belong to Class1. Execute the following commands on a node that belongs to the scope of class Class1.

1-1) Stop proxy volume Volume2. Specify the `-e allnodes` option to stop Volume2 on all nodes.

```
# sdxvolume -F -c Class1 -v Volume2
```



Information

When using GDS Management View, select a proxy volume and execute [Operation]:[Stop

Volume] in the Main Screen.

1-2) Relate and join proxy volume Volume2 to master volume Volume1.

```
# sdxproxy Join -c Class1 -m Volume1 -p Volume2
```

After returning from the command, synchronization copying from Volume1 to Volume2 is executed.



Information Relating and Joining a Pair of Groups

If the proxy group includes volumes, remove the volumes before executing the sdxproxy Join command, and also specify the -a option for this command.



See

When using GDS Management View, see "5.2.3.1 Join."

2) Confirming the completion of copying

Confirm that the synchronization copying is complete.

```
# sdxinfo -S -c Class1 -o Volume2
```

OBJ	CLASS	GROUP	DISK	VOLUME	STATUS
slice	Class1	Group2	Disk3	Volume2	STOP
slice	Class1	Group2	Disk4	Volume2	STOP

If all the displayed slices' STATUS fields are "STOP", synchronization copying is complete. If the synchronization copying is still in progress, "COPY" will be displayed in the STATUS field.

3) Stopping the services

To secure consistency of snapshot data, stop the services before creating a snapshot and restrain the master volume from being written in.

3a) When the master volume is being used for a cluster application
Inactivate the cluster application.

3b) When the master volume is not being used for a cluster application
3b-1) Stop the services for which the master volume is being used.

3b-2) When the master volume is being used as a file system, unmount the file system. This example shows the procedure when the mount point is /DATA.

```
# cd /  
# umount /DATA
```

4) Parting the proxy volume

Create a snapshot of master volume Volume1 by parting proxy volume Volume2 from master volume Volume1. Execute the following commands on a node that belongs to the scope of class Class1.

```
# sdxproxy Part -c Class1 -p Volume2
```



See

When using GDS Management View, see "Part" in "5.3.2.2 Backup (by Synchronization)." For setting of the part environment, select "No" to "Instant Snapshot".

5) Resuming the services

5a) When the master volume is used for a cluster application
Activate the cluster application.

5b) When the master volume is not used for a cluster application

5b-1) When the master volume is used as a file system, mount the file system. This example shows the procedure when the ext3 file system on master volume Volume1 is mounted on mount point /DATA.

```
# mount -t ext3 /dev/sfdsk/Class1/dsk/Volume1 /DATA
```

5b-2) Start the services for which the master volume is used.

6) Backing up to tape

Back up the snapshot data on the proxy volume to tape. Execute the following commands on a node that belongs to the scope of class Class1.



See

For details about the backup method, see manuals of a file system to be backed up and used commands.

6a) When backing up data held in a raw device with the dd(1) command

```
# dd if=/dev/sfdsk/Class1/rdsk/Volume2 of=/dev/st0 bs=32768
```

6b) When backing up the ext3 file system with the tar(1) command

6b-1) Before mounting

Check and repair consistency of the ext3 file system on the proxy volume with the fsck(8) command. When the file system on the master volume was unmounted in step 3b-2), skip this step.

```
# fsck -t ext3 /dev/sfdsk/Class1/dsk/Volume2
```

6b-2) Mounting the snapshot

Mount the ext3 file system on proxy volume Volume2 on temporary mount point /DATA_backup.

```
# mkdir /DATA_backup
# mount -t ext3 /dev/sfdsk/Class1/dsk/Volume2 /DATA_backup
```

6b-3) Backing up to tape

This example shows the procedure when data is backed up to a tape medium of tape device /dev/st0 with the tar(1) command.

```
# cd /DATA_backup
# tar cvf /dev/st0 .
```

6b-4) Unmounting the snapshot

Unmount the file system mounted in step 6b-2).

```
# cd /
# umount /DATA_backup
# rmdir /DATA_backup
```

7) Rejoining the proxy volume

To perform online backup again, follow the procedures below on a node that belongs to the scope of class Class1 and then go back to step 2.

7-1) Stop proxy volume Volume2. Specify the -e allnodes option to stop Volume2 on all nodes.

```
# sdxvolume -F -c Class1 -v Volume2
```



Information

When using GDS Management View, select a proxy volume and execute [Operation]:[Stop Volume] in the Main Screen.

7-2) Rejoin proxy volume Volume2 to master volume Volume1.

```
# sdxproxy Rejoin -c Class1 -p Volume2
```

After returning from the command, synchronization copying from Volume1 to Volume2 is performed.



See

When using GDS Management View, see "Rejoin" of "5.3.2.2 Backup (by Synchronization)."

8) Breaking the proxy volume

When no more online backup is executed, cancel the relationship between master volume Volume1 and proxy volume Volume2.

```
# sdxproxy Break -c Class1 -p Volume2
```



See

When using GDS Management View, see "5.5.5 Breaking a Proxy."

6.2.2 Online Backup (Snapshot by OPC)

If GDS Snapshot is installed in a system where a disk array unit with the OPC function is used, backup can be performed through instant snapshot by OPC using proxy volumes without stopping services.

However, to secure consistency of snapshot data, the services must be stopped temporarily when creating a snapshot (when updating proxy volumes).



See

For securing consistency of snapshot data, see "A.2.15 Ensuring Integrity of Snapshot Data."

Figure: Backup Schedule

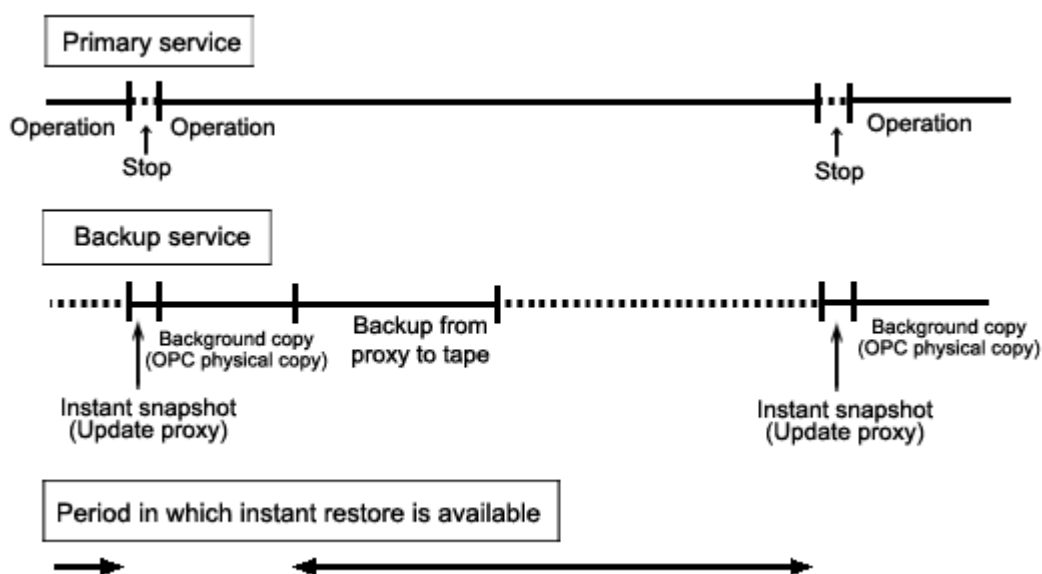

Information Background Copy (OPC Physical Copy) and Backup to Tape

During the copying process, data can be backed up to tape, but the backup will impose the load to the disk array unit and may affect services using master volumes.



Note Instant Snapshot by OPC

For use conditions for instant snapshot by OPC, see "A.2.14 Instant Snapshot by OPC." If proxy volumes are in mirroring configuration with the multiplicity of two and higher, the OPC function is unavailable for copying data from master volumes to the proxy volumes. For details, see "A.2.13 Using the Advanced Copy Function in a Proxy Configuration."

[Procedures]

1) Relating a proxy volume

Before creating snapshots, relate proxy volume Volume2 as a copy destination to master volume Volume1. In this example, Volume1 and Volume2 belong to class Class1. Execute the following command on a node that belongs to the scope of Class1.

```
# sdxproxy Relate -c Class1 -m Volume1 -p Volume2
```



See

When using GDS Management View, see "5.2.3.2 Relate."

2) Stopping the proxy volume

Stop proxy volume Volume2. Specify the -e allnodes option to stop Volume2 on all nodes.

```
# sdxvolume -F -c Class1 -v Volume2
```



Information

When using GDS Management View, select a proxy volume and execute [Operation]:[Stop Volume] in the Main Screen.

3) Stopping the services

To secure consistency of snapshot data, stop the services before creating a snapshot and restrain the master volume from being written in.

3a) When the master volume is being used for a cluster application
Inactivate the cluster application.

3b) When the master volume is not being used for a cluster application
3b-1) Stop the services for which the master volume is being used.

3b-2) When the master volume is being used as a file system, unmount the file system. This example shows the procedure when the mount point is /DATA.

```
# cd /  
# umount /DATA
```

4) Updating the proxy volume

Copy data from master volume Volume1 to proxy volume Volume2 with the OPC function to update Volume2 with the data of Volume1 at the moment. Execute the following command on a node that belongs to the scope of class Class1.

```
# sdxproxy Update -c Class1 -p Volume2 -e instant
```

When returning from the command, the update of Volume2 will be complete. Subsequently, background OPC physical copying is performed, but you may go on to step 5 without waiting until the copying is complete.



See

When using GDS Management View, see "Update" in "5.3.2.3 Backup (by OPC)." For setting of the update environment, select "Yes" to "Instant Snapshot".

5) Resuming the services

5a) When the master volume is used for a cluster application
Activate the cluster application.

5b) When the master volume is not used for a cluster application

5b-1) When the master volume is used as a file system, mount the file system. This example shows the procedure when the ext3 file system on master volume Volume1 is mounted on mount point /DATA.

```
# mount -t ext3 /dev/sfdsk/Class1/dsk/Volume1 /DATA
```

5b-2) Start the services for which the master volume is used.

6) Starting the proxy volume

Start proxy volume Volume2 on a node where backup to tape is performed.

```
# sdxvolume -N -c Class1 -v Volume2
```



Information

When using GDS Management View, select a proxy volume and execute [Operation]:[Start Volume] in the Main Screen.

7) Confirming the completion of copying

Confirm that the copying is complete.

OBJ	CLASS	GROUP	DISK	VOLUME	STATUS
slice	Class1	Group2	Disk3	Volume2	ACTIVE
slice	Class1	Group2	Disk4	Volume2	ACTIVE

If all the displayed slices' STATUS fields are "ACTIVE", copying is complete.
If the copying is still in progress, "COPY" will be displayed in the STATUS field.

8) Backing up to tape

Back up the snapshot data on the proxy volume to tape. Execute the following commands on a node that belongs to the scope of class Class1.



See

For details about the backup method, see manuals of a file system to be backed up and used commands.

8a) When backing up data held in a raw device with the dd(1) command

```
# dd if=/dev/sfdsk/Class1/rdisk/Volume2 of=/dev/st0 bs=32768
```

8b) When backing up the ext3 file system with the tar(1) command

8b-1) Before mounting

Check and repair consistency of the ext3 file system on the proxy volume with the fsck(8) command.
When the file system on the master volume was unmounted in step 3b-2), skip this step.

```
# fsck -t ext3 /dev/sfdsk/Class1/dsk/Volume2
```

8b-2) Mounting the snapshot

Mount the ext3 file system on proxy volume Volume2 on temporary mount point /DATA_backup.

```
# mkdir /DATA_backup  
# mount -t ext3 /dev/sfdsk/Class1/dsk/Volume2 /DATA_backup
```

8b-3) Backing up to tape

This example shows the procedure when data is backed up to a tape medium of tape device /dev/st0 with the tar(1) command.

```
# cd /DATA_backup  
# tar cvf /dev/st0 .
```

8b-4) Unmounting the snapshot

Unmount the file system mounted in step 8b-2).

```
# cd /  
# umount /DATA_backup  
# rmdir /DATA_backup
```

9) Stopping the proxy volume

After backing up to tape, stop Volume2 to protect data in proxy volume Volume2. Specify the -e allnodes option to stop Volume2 on all the nodes.

```
# sdxvolume -F -c Class1 -v Volume2
```



Information

When using GDS Management View, select a proxy volume and execute [Operation]:[Stop Volume] in the Main Screen.

10) Breaking the proxy volume

When no more online backup is to be executed, cancel the relationship between master volume Volume1 and proxy volume Volume2.

```
# sdxproxy Break -c Class1 -p Volume2
```



When using GDS Management View, see "5.5.5 Breaking a Proxy."

11) Re-executing online backup

To perform online backup again, go back to step 3.

6.2.3 Instant Restore

By keeping proxy volumes parted from master volumes used for services, in the event of a data error in a master volume, data can be restored back from the proxy volume to the master volume (unless background copying is in process after instant snapshot creation).

The master volume must be stopped temporarily for restoration, but you may start the master volume and make it accessible immediately after the restore is initiated without waiting until the copying is complete.



Information Restore from Tape

If an error occurs in master volume data while the master volume used for the services operation and a proxy volume are joined, the same error occurs in data of the proxy volume and instant restore becomes unavailable. If this happens, restore data back to the master volume following the procedure described in "6.1.3 Restoring."

Figure: Schedule for Instant Restore

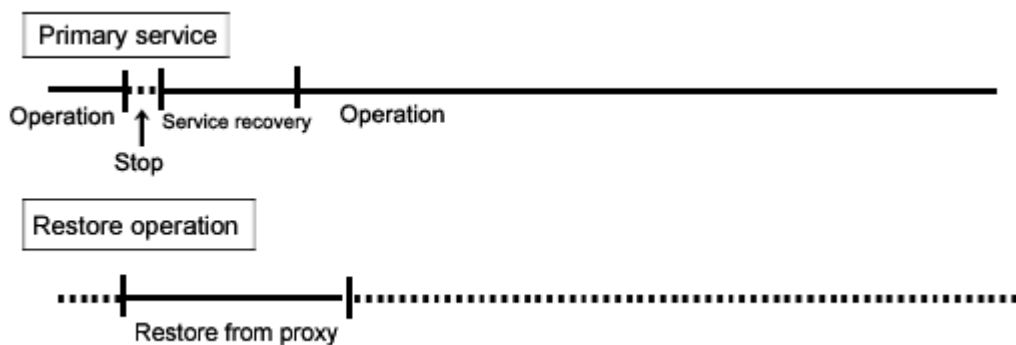

Note Instant Restore with Disk Unit Copy Functions

For restore, (R)OPC is only available, but (R)EC is unavailable. For details, see "A.2.13 Using the Advanced Copy Function in a Proxy Configuration."

Procedure

1) Viewing the state of the proxy volume

Confirm that proxy volume Volume2 has been parted from master volume Volume1.

```
# sdxinfo -V -c Class1 -o Volume2 -e long
```

OBJ	NAME	TYPE	CLASS	GROUP	DISK	MASTER	PROXY ...
volume	*	mirror	Class1	Group2	*	*	* ...
volume	Volume2	mirror	Class1	Group2	*	Volume1	Part ...
volume	*	mirror	Class1	Group2	*	*	* ...

If Part is displayed in the PROXY field, the proxy volume has been parted.

If Join is displayed in the PROXY field, the proxy volume has been joined to the master volume and instant restore is unavailable. In this situation, data must be restored from tape. For more details, see "Restore from Tape" described above.

2) Stopping the services

2a) When the master volume is being used for a cluster application
Inactivate the cluster application.

2b) When the master volume is not being used for a cluster application

2b-1) Stop the services for which the master volume is being used.

2b-2) When the master volume is being used as a file system, unmount the file system. This example shows the procedure when the mount point is /DATA.

```
# cd /  
# umount /DATA
```

2b-3) Stopping the master volume

Stop master volume Volume1. Specify the -e allnodes option to stop Volume1 on all nodes.

```
# sdxvolume -F -c Class1 -v Volume1
```



Information

When using GDS Management View, select a master volume and execute [Operation]:[Stop Volume] in the Main Screen.

3) Restoring data from the proxy volume

Execute the following commands on a node that belongs to the scope of class Class1.

3a) When the OPC function is unavailable

3a-1) Stop proxy volume Volume2. Specify the -e allnodes option to stop Volume2 on all nodes.

```
# sdxvolume -F -c Class1 -v Volume2
```



Information

When using GDS Management View, select a proxy volume and execute [Operation]:[Stop Volume] in the Main Screen.

3a-2) Restore data from proxy volume Volume2 back to master volume Volume1.

```
# sdxproxy RejoinRestore -c Class1 -p Volume2 -e instant
```

When returning from the command, the restore of Volume1 will be complete. Subsequently, synchronization copying from Volume2 to Volume1 is performed, and you may go on to step 4 without waiting until the copying is complete.



See

When using GDS Management View, see "Restore" in "5.3.3 Restore." For settings of the restore environment, select "Yes" to "Rejoin" and "Yes" to "Instant Restore".

3b) When the OPC function is available

Restore data from proxy volume Volume2 back to master volume Volume1.

```
# sdxproxy Restore -c Class1 -p Volume2 -e instant
```

When returning from the command, the restore of Volume1 will be complete. Subsequently, background OPC physical copying from Volume2 to Volume1 is performed, and you may go on to step 4 without waiting until the copying is complete.



See

When using GDS Management View, see "5.3.3 Restore." For settings of the restore environment, select "No" to "Rejoin" and "yes" to "Instant Restore".



Note Master Volumes with the Mirroring Multiplicity of Two and Higher

By executing the sdxproxy Restore command in step 3b), OPC starts, copying from one of proxy volume's slices to one of master volume's slices. Among slices of the master volume, slices other than the OPC copy destination are excluded from mirroring and thus the data statuses become invalid. To recover the master volume mirroring status, perform master volume resynchronization copying by using the sdxcopy -B command. If not executing the sdxcopy -B command, master volume resynchronization copying automatically starts when starting the master volume in step 4) and data will be copied from the OPC copy destination slice to the other slices with the soft copy function.

4) Resuming the services

Without waiting until the copying is complete, you may resume the services.



Note Reusing Proxy Volume Data

By executing the sdxproxy RejoinRestore command in step 3a), Volume1 and Volume2 are joined and Volume2 will also be updated with data written into Volume1. To reuse data in Volume2 for restore without updating, after the synchronization copying from Volume2 to Volume1 is complete, part Volume2 from Volume1 and then resume the services. When the sdxproxy Restore command was executed in step 3b), Volume1 and Volume2 are left parted, and data in Volume2 remains unchanged even if the services are resumed before the copying is complete.

4a) When the master volume is used for a cluster application
Activate the cluster application.

4b) When the master volume is not used for a cluster application
4b-1) Activate master volume Volume1 on the node running the services.

```
# sdxvolume -N -c Class1 -v Volume1
```



Information

When using GDS Management View, select the master volume and execute [Operation]:[Start Volume] in the Main Screen.



Information When the OPC Function Is Available

If the master volume mirroring multiplicity is two and higher and if restore is performed with the OPC function in step 3b), master volume resynchronization copying automatically starts after this command execution. To perform resynchronization copying after OPC physical copying is complete, specify the -e nosync option for the sdxvolume -N command, and the master volume will start without invoking resynchronization copying. With this method, perform master volume resynchronization copying with the sdxcopy -B command after OPC physical copying is complete.

4b-2) When the master volume is used as a file system, mount the file system. In this example, the mount point is /DATA.

- For the ext3 file system

```
# mount -t ext3 /dev/sfdsk/Class1/dsk/Volume1 /DATA
```

4b-3) Resume the servicess using the master volume.

5) Viewing the copy status

The status of the copying from proxy volume Volume2 to master volume Volume1 started in step 3) can be viewed by using the sdxinfo -S command. The copy destination slice is in the COPY status if copying is in progress and it will be in the ACTIVE status after the copy process ends normally.

```
# sdxinfo -S -c Class1 -o Volume1
OBJ CLASS GROUP DISK VOLUME STATUS
-----
slice Class1 Group1 Disk1 Volume1 ACTIVE
slice Class1 Group1 Disk2 Volume1 ACTIVE
```



Information

By executing the `sdxproxy RejoinRestore` command in step 3a), master volume Volume1 and proxy volume Volume2 are joined. In the event of a data error occurs in Volume1, the same data error occurs in Volume2, and restoring data back from tape will be required. Therefore, after resynchronization copying from Volume2 to Volume1 is complete, it is recommended to part Volume2 from Volume1. For the procedures for parting proxy volumes, see the procedures 3) through 5) in "6.2.1 Online Backup (by Synchronization)."



Note When Using (R)EC for Backup

Restoration of the master by use of the proxy stops sessions of these copying functions. To perform backup using these copying functions, cancel the relation between the master and the proxy with the `sdxproxy Break` command.

6.3 Backing Up and Restoring through an External Server

This section discusses the method of backing up data from and restoring data back to logical volumes (called application volumes in this manual) in a shared class in the primary domain through a server in a domain different from the primary domain (called an external backup server in this manual).

The backup and restore operations through an external backup server can be categorized into 3 patterns.

1. Backing up and restoring a logical volume with no replication



See

For details, see "6.3.1"

2. Backing up and restoring through snapshot by slice detachment



See

For details, see "6.3.2"

3. Backing up and restoring using snapshots from a proxy volume



See

For details, see "6.3.3"

The following table summarizes characteristics of the respective operations.

Patterns	Online backup	Backed up target	Disk unit's copy function	Application volume type (*1)	Required component (primary domain) (*2)
1	Not available	Application volumes	-	Any	GDS
2	Available	Slices detached temporarily	-	One of (*3): mirror (concat+mirror) (stripe+mirror)	GDS
3	Available	Proxy volumes	-	One of (*4): single mirror concat+mirror stripe+mirror	GDS GDS Snapshot
			Advanced Copy function	One of (*5): single mirror	

(*1):

The table above describes the volume types according to the following classification.

Type	Description
single	Single volume created in a single disk.
mirror	Mirror volume connected to a mirror group to which one or more disks are connected. This is excluded when a lower level group is connected to the mirror group. Making disk data redundant can improve the services continuity.
concat	Volume created in a concatenation group. When no large volume exists, it can be created by concatenating multiple disks.
stripe	Stripe volume created in a stripe group. I/O loads of the services can be balanced up on multiple disks.
concat + mirror	Mirror volume created in a mirror group to which one or more concatenation groups are connected. This is excluded when a disk is connected to the mirror group. The effects of both concat and mirror can be gained.
stripe + mirror	Mirror volume created in a mirror group to which one or more stripe group are connected. This is excluded when a disk is connected to the mirror group. The effects of both stripe and mirror can be gained.

(concat mirror)	+	Mirror volume created in a mirror group to which one disk and one or more concatenation groups are connected. Since the size of this volume is limited by the size of the disk connected to the mirror group, the effects of concat cannot be gained.
(stripe mirror)	+	Mirror volume created in a mirror group to which one disk and one or more stripe group are connected. Since I/O loads to the disk connected to the mirror group are not balanced up, the effects of stripe cannot be gained. However, while the slice is temporarily detached from the disk, the effects of stripe can be gained since I/O loads to the volume are balanced up on multiple disks connected to the stripe group. Note, however, that a slice cannot be temporarily detached from a master volume related to a proxy volume.

(*2):

For an external backup server, GDS and GDS Snapshot must be implemented for creating shadow volumes.

(*3):

See "A.2.8 Creating a Snapshot by Slice Detachment."

(*4):

See "A.1.7 Exception to Proxy Configuration."

(*5):

See "A.1.7 Exception to Proxy Configuration" and "A.2.13 Using the Advanced Copy Function in a Proxy Configuration."

6.3.1 Backing Up and Restoring a Logical Volume with No Replication

This sub-section describes the method of backing up data from and restoring data back to logical volumes in the primary domain through a backup server in another domain.

The following is an example of backing up and restoring a stripe volume. Mirror volumes, single volumes, and volumes in concatenation groups can also be backed up and restored in a similar manner. However, for backing up mirror volumes, the method described in "6.3.2 Backing Up and Restoring through Snapshot by Slice Detachment" is recommended.

6.3.1.1 System Configuration

Figure: System Configuration

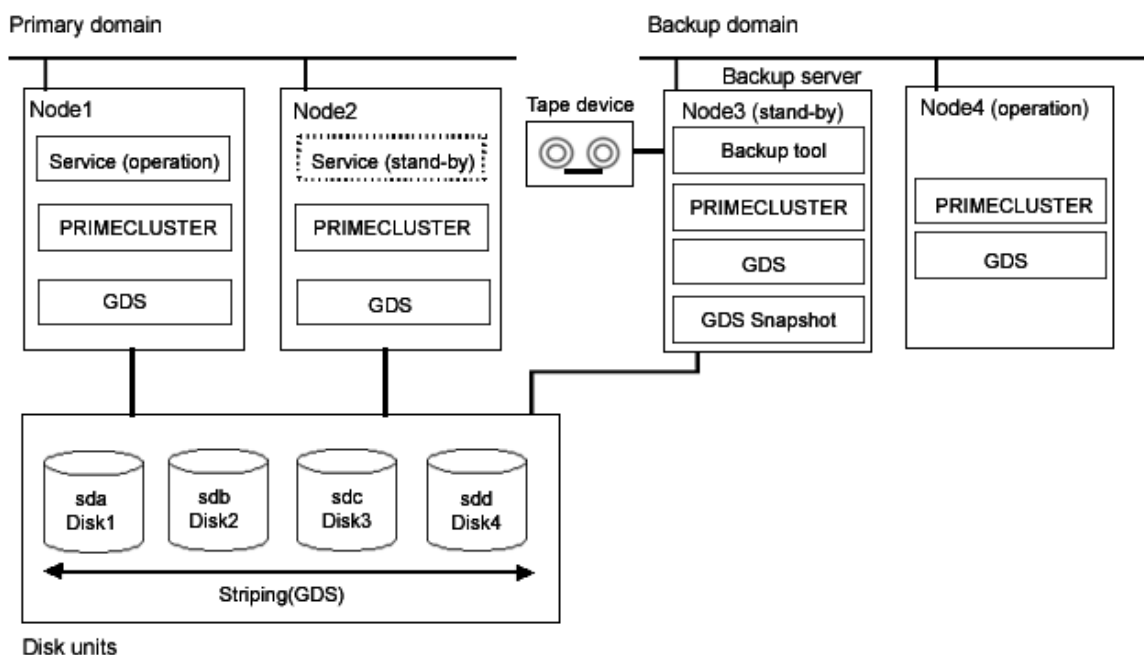

Note Physical Device Name

Different physical device names (such as sda) may be assigned to the identical physical disk in the primary domain and the backup server.

Figure: Object Configuration in Normal Operation

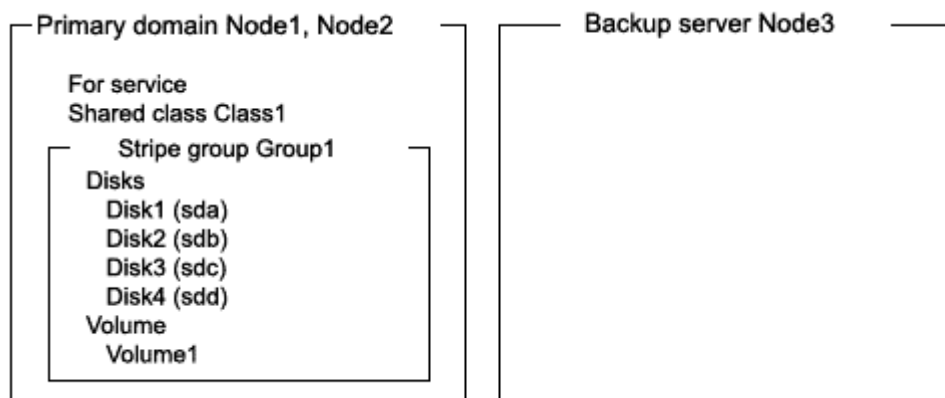

6.3.1.2 Summary of Backup

Backups can be created while the services are stopped and the application volume is not in use.

Figure: Backup

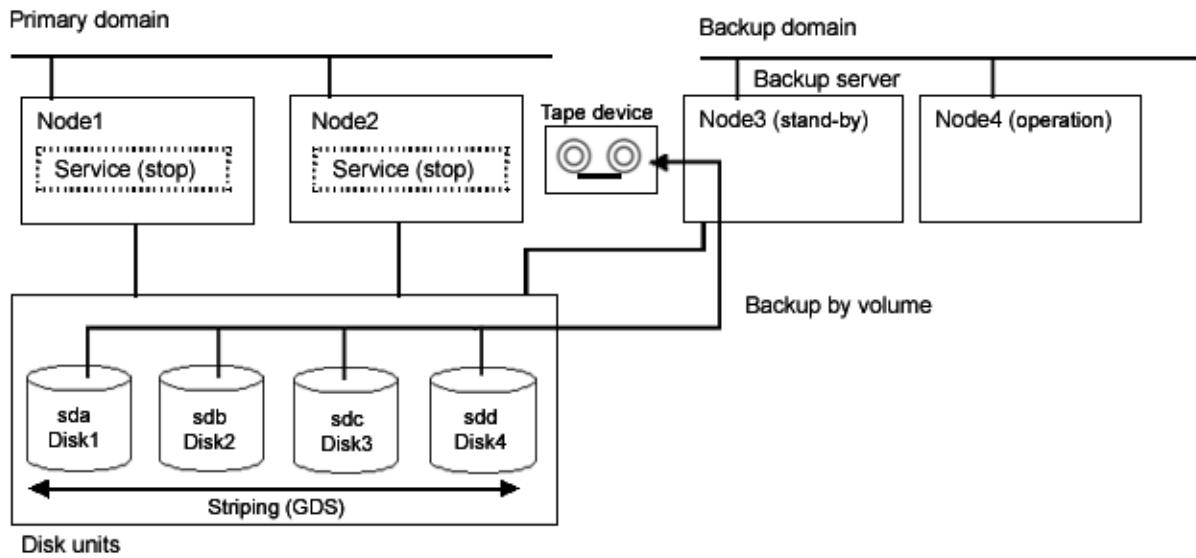

Figure: Object Configuration When Backing Up

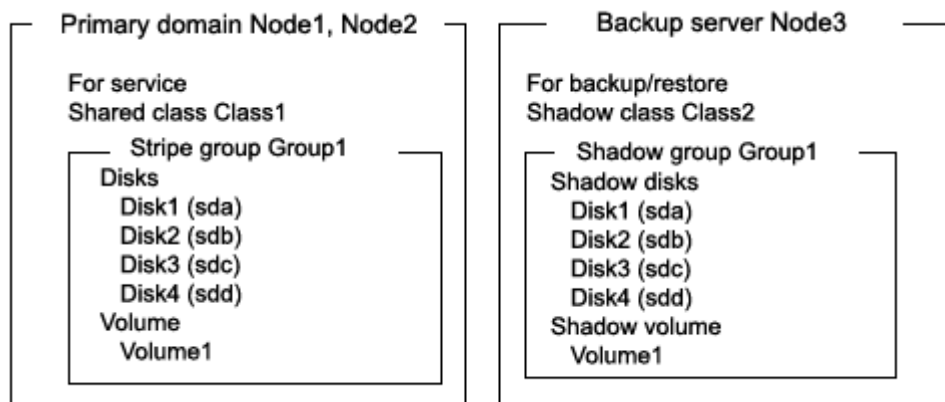
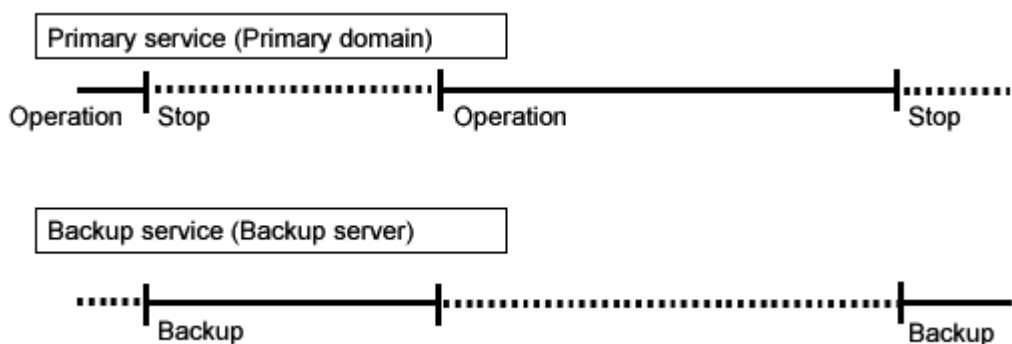

Figure: Backup Schedule



6.3.1.3 Summary of Restore

If volume data is damaged, it can be restored from tape. Data can be restored while the services are stopped and the application volume is not in use.

Figure: Restore

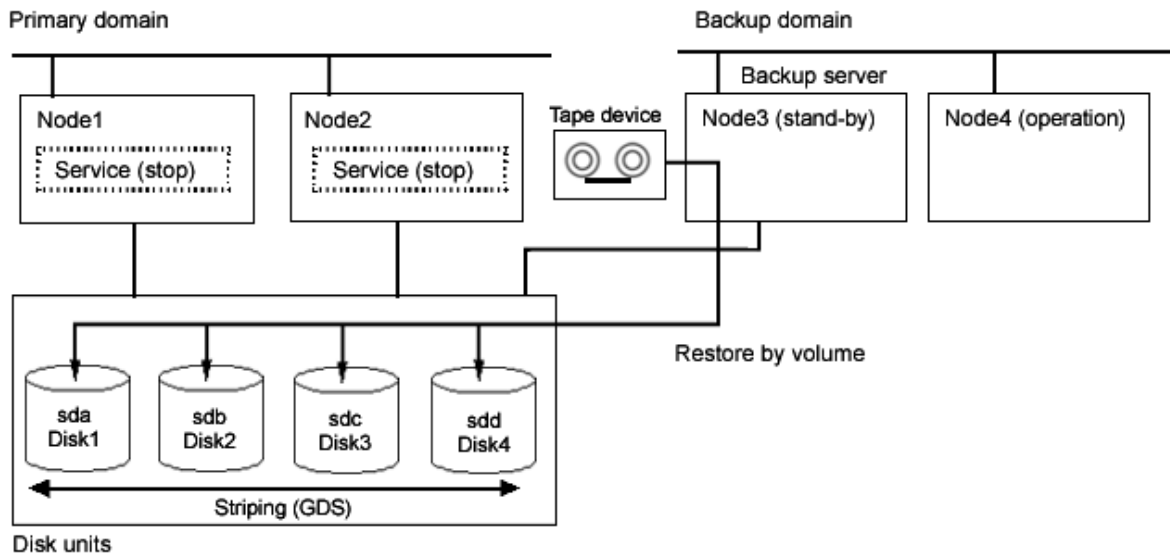

Figure: Object Configuration When Restoring

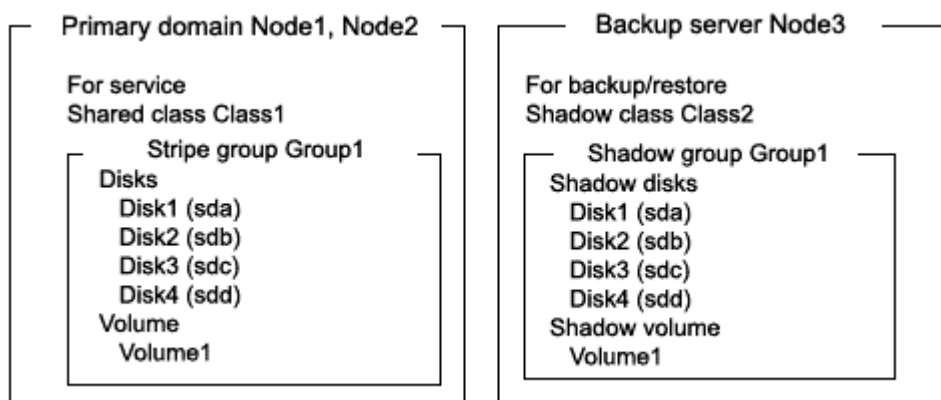
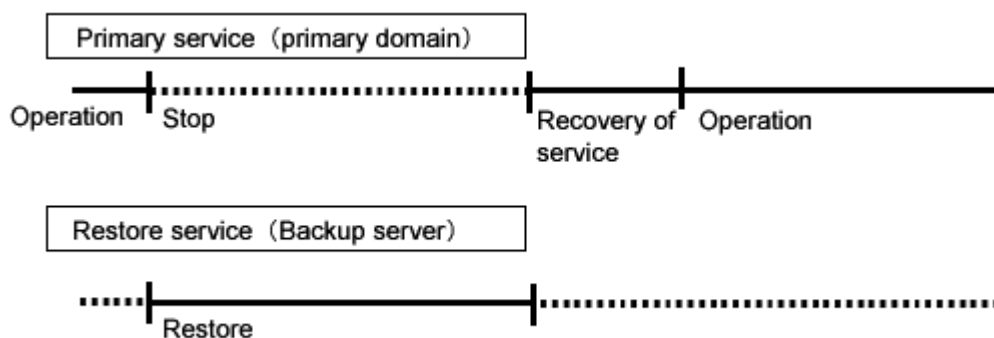

Figure: Restore Schedule



6.3.1.4 Summary of Procedure

Figure: Outline of the Configuration Procedure



Figure: Outline of the Backup Procedure

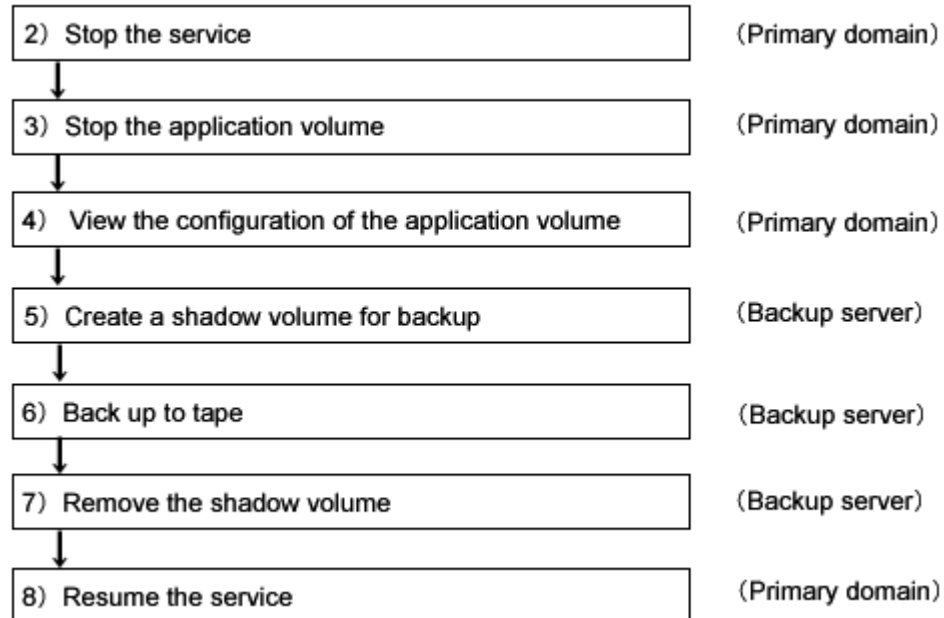
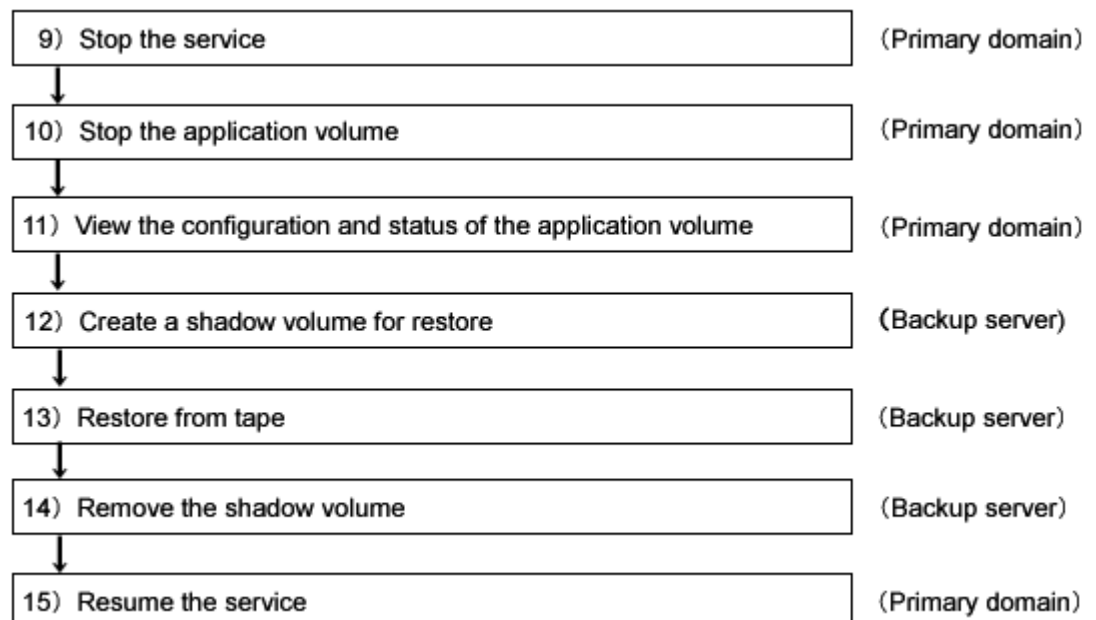

Figure: Outline of the Restore Procedure



6.3.1.5 Configuring an Environment



Note Automatic Resource Registration

Disks that are registered as resources in the primary domain or are to be registered with a shadow class in the backup domain may not be involved in the resource registration in the backup domain. For details about the automatic resource registration, see “Appendix H Register shared disk units.”

1) Creating an application volume

Create a stripe volume used for the services on disks sda, sdb, sdc, and sdd. The following settings are necessary on Node1 or Node2 in the primary domain.

1-1) Registering disks

Register disks sda, sdb, sdc, and sdd with shared class Class1 that is shared on Node1 and Node2, and name them Disk1, Disk2, Disk3, and Disk4 respectively.

```
# sdxdisk -M -c Class1 -a type=shared,scope=Node1:Node2 -d  
sda=Disk1,sdb=Disk2,cdc=Disk2,sdd=Disk4
```

1-2) Creating a stripe group

Connect disks Disk1, Disk2, Disk3, and Disk4 to stripe group Group1.

```
# sdxdisk -C -c Class1 -g Group1 -d Disk1,Disk2,Disk3,Disk4 -a type=stripe,width=256
```

1-3) Creating a stripe volume

Create stripe volume Volume1 to stripe group Group1.

```
# sdxvolume -M -c Class1 -g Group1 -v Volume1 -s 1048576 -a pslice=off
```

6.3.1.6 Backing Up

2) Stopping the services

Exit all applications accessing the application volume Volume1 in the primary domain on Node1 and Node2.

When Volume1 is used as a file system, it should be unmounted.

3) Stopping the application volume

To write-lock volume Volume1, inactivate Volume1 on Node1 and Node2 in the primary domain. Execute the following command on Node1 or Node2.

```
# sdxvolume -F -c Class1 -v Volume1 -e allnodes
```

4) Viewing the configuration of the application volume

On Node1 or Node2 in the primary domain, view the configuration of application volume Volume1 that is the backup target.

```
# sdxinfo -c Class1
```

OBJ	NAME	TYPE	SCOPE	SPARE					
class	Class1	shared	Node1:Node2	0					
OBJ	NAME	TYPE	CLASS	GROUP	DEVNAM	DEVBLKS	DEVCONNECT	STATUS	
disk	<u>Disk1</u>	stripe	Class1	Group1	sda	8380800	Node1:Node2	ENABLE	
disk	<u>Disk2</u>	stripe	Class1	Group1	sdb	8380800	Node1:Node2	ENABLE	
disk	<u>Disk3</u>	stripe	Class1	Group1	sdc	8380800	Node1:Node2	ENABLE	
disk	<u>Disk4</u>	stripe	Class1	Group1	sdd	8380800	Node1:Node2	ENABLE	
OBJ	NAME	CLASS	DISKS			BLKS	FREEBLKS	SPARE	
group	Group1	Class1	<u>Disk1:Disk2:Disk3:Disk4</u>			32964608	31850496	*	
OBJ	NAME	CLASS	GROUP	SKIP	JRM	1STBLK	LASTBLK	BLOCKS	STATUS
volume	*	Class1	Group1	*	*	0	65535	65536	PRIVATE
volume	Volume1	Class1	Group1	*	*	<u>65536</u>	1114111	<u>1048576</u>	STOP
volume	*	Class1	Group1	*	*	1114112	32964607	31850496	FREE
OBJ	CLASS	GROUP	DISK	VOLUME		STATUS			
slice	Class1	Group1	*	Volume1		STOP			

If application volume Volume1 belongs to a stripe group, also pay attention to the stripe width.

```
# sdxinfo -G -c Class1 -o Group1 -e long
```

OBJ	NAME	CLASS	DISKS	BLKS	FREEBLKS	SPARE	MASTER	TYPE	WIDTH
group	Group1	Class1	Disk1:Disk2:Disk3:Disk4	32964608	31850496	*	*	stripe	<u>256</u>

5) Creating a shadow volume for backup

On backup server Node3, create a backup volume (shadow volume) in the same configuration as the application volume found in step 4). The following settings are necessary on the backup server.



Note

Application volume data may be damaged if data is written into a shadow volume in improper configuration. Be sure to confirm that the shadow volume configuration is proper in step 5-4).

5-1) Registering shadow disks

Register disks sda, sdb, sdc, and sdd with shadow class Class2, and name them Disk1, Disk2, Disk3, and Disk4 respectively.

```
# sdxshadowdisk -M -c Class2 -d sda=Disk1,sdb=Disk2,sdc=Disk3,sdd=Disk4
```



Point

- The disk names must correspond to the disk names assigned in step 1-1). The disk names assigned in 1-1) can be viewed in the NAME field for disk information displayed with the sdxinfo command in step 4).
- The class can be assigned any name.

5-2) Creating a shadow group

Connect shadow disks Disk1, Disk2, Disk3, and Disk4 to stripe type shadow group Group1.

```
# sdxshadowdisk -C -c Class2 -g Group1 -d Disk1,Disk2,Disk3,Disk4 -a type=stripe,width=256
```



Point

- If the application volume belongs to a stripe group or a concatenation group, the order of connecting shadow disks to a shadow group must correspond to the order of connecting disks to a group in step 1-2). The order of connecting disks in step 1-2) can be viewed in the DISKS field for group information displayed with the sdxinfo command in step 4).

- When the application volume belongs to a stripe group, the stripe width of a shadow group must correspond to the stripe width specified in step 1-2). The stripe width specified in step 1-2) can be viewed in the WIDTH field for group information displayed with the `sdxinfo -e` long command in step 4).
- The group can be assigned any name.

5-3) Create a shadow volume.

Create shadow volume Volume1 to shadow group Group1.

```
# sdxshadowvolume -M -c Class2 -g Group1 -v Volume1 -s 1048576
```



Point

- The volume must be created in the size corresponding to the volume size in step 1-3). The size of a volume created in step 1-3) can be viewed in the BLOCKS field for volume information displayed with the `sdxinfo` command in step 4).
- If there are multiple volumes, the corresponding shadow volumes must be created in the order of ascending values (first block numbers) in the 1STBLK field for volume information displayed with the `sdxinfo` command in step 4).
- The volume can be assigned any name.

5-4) Viewing the shadow volume configuration

Using the `sdxinfo` command, confirm that the group configuration and the volume configuration are proper based on group information in the DISKS field, volume information in the 1STBLK field and in the BLOCKS field and so on.

```
# sdxinfo -c Class2
OBJ  NAME  TYPE  SCOPE  SPARE
-----
class Class2 shared Node3 0

OBJ  NAME  TYPE  CLASS  GROUP  DEVNAM  DEVBLKS  DEVCONNECT  STATUS
-----
disk Disk1 stripe Class2 Group1 sda      8380800  Node3     ENABLE
disk Disk2 stripe Class2 Group1 sdb      8380800  Node3     ENABLE
disk Disk3 stripe Class2 Group1 sdc      8380800  Node3     ENABLE
disk Disk4 stripe Class2 Group1 sdd      8380800  Node3     ENABLE

OBJ  NAME  CLASS  DISKS                BLKS  FREEBLKS  SPARE
-----
group Group1 Class2 Disk1:Disk2:Disk3:Disk4 32964608 31850496 *
```

```
OBJ  NAME  CLASS  GROUP  SKIP  JRM  1STBLK  LASTBLK  BLOCKS  STATUS
-----
volume *      Class2 Group1 *      *      0      65535   65536   PRIVATE
volume Volume1 Class2 Group1 *      *      65536 1114111 1048576 ACTIVE
volume *      Class2 Group1 *      *      1114112 32964607 31850496 FREE

OBJ  CLASS  GROUP  DISK  VOLUME  STATUS
-----
slice Class2 Group1 *      Volume1 ACTIVE
```

For a stripe volume, see also the stripe width.

```
# sdxinfo -G -c Class2 -o Group1 -e long
OBJ  NAME  CLASS  DISKS                BLKS  FREEBLKS  SPARE  MASTER  TYPE  WIDTH
-----
group Group1 Class2 Disk1:Disk2:Disk3:Disk4 32964608 31850496 *      *      stripe 256
```

6) Backing up to tape

On backup server Node3, back up data from the shadow volume to tape. In the following examples, back up data in shadow volume Volume1 to a tape medium of tape device `/dev/st0`.



See

For details about the backup method, see manuals of a file system to be backed up and used commands.



Information In a GFS Shared File System

Back up through the method as described in step 6a).

6a) When backing up data held in a raw device with the dd(1) command

```
# dd if=/dev/sfdsk/Class2/rdisk/Volume1 of=/dev/st0 bs=32768
```

6b) When backing up a ext3 file system with the tar(1) command

6b-1) Mount the ext3 file system on shadow volume Volume1 on /mnt1, a temporary mount point, in read only mode.

```
# mkdir /mnt1  
# mount -t ext3 -o ro /dev/sfdsk/Class2/dsk/Volume1 /mnt1
```

6b-2) Back up data held in the file system to tape.

```
# cd /mnt1  
# tar cvf /dev/st0 .
```

6b-3) Unmount the file system mounted in step 6b-1).

```
# cd /  
# umount /mnt1  
# rmdir /mnt1
```

7) Removing the shadow volume

After the backup process is complete, remove the shadow volume to prevent improper access to it. The following procedure must be performed on backup server Node3.

7-1) Stopping the shadow volume

Stop shadow volume Volume1.

```
# sdxshadowvolume -F -c Class2 -v Volume1
```

7-2) Removing the shadow volume

Remove shadow volume Volume1.

```
# sdxshadowvolume -R -c Class2 -v Volume1
```

7-3) Removing the shadow group

Remove shadow group Group1.

```
# sdxshadowgroup -R -c Class2 -g Group1
```

7-4) Removing the shadow disks

Remove shadow disks Disk1, Disk2, Disk3, and Disk4.

```
# sdxshadowdisk -R -c Class2 -d Disk1  
# sdxshadowdisk -R -c Class2 -d Disk2  
# sdxshadowdisk -R -c Class2 -d Disk3  
# sdxshadowdisk -R -c Class2 -d Disk4
```

8) Resuming the services

Resume the services in the primary domain. The following procedure must be performed on the node that runs the services.

8-1) Activating the application volume

Activate application volume Volume1.

```
# sdxvolume -N -c Class1 -v Volume1
```

8-2) Resuming the services

When the file system on application volume Volume1 was unmounted in step 2), mount it again. Launch the applications that use Volume1.

6.3.1.7 Restoring

9) Stopping the services

Exit all applications accessing application volume Volume1 on Node1 and Node2 in the primary domain. When Volume1 is used as a file system, it should be unmounted.

10) Stopping the application volume

To write-lock volume Volume1, inactivate Volume1 on Node1 and Node2 in the primary domain. Execute the following command on Node1 or Node2.

```
# sdxvolume -F -c Class1 -v Volume1 -e allnodes
```

11) Viewing the configuration and status of the application volume

On Node1 or Node2 in the primary domain, view the configuration and status of application volume Volume1 that is the restore target. Confirm that Volume1 is in the STOP status. If the volume status is improper, repair it referencing to "F.1.3 Volume Status Abnormality"

```
# sdxinfo -c Class1
```

OBJ	NAME	TYPE	SCOPE	SPARE
class	Class1	shared	Node1:Node2	0

OBJ	NAME	TYPE	CLASS	GROUP	DEVNAM	DEVBLKS	DEVCONNECT	STATUS
disk	<u>Disk1</u>	stripe	Class1	Group1	sda	8380800	Node1:Node2	ENABLE
disk	<u>Disk2</u>	stripe	Class1	Group1	sdb	8380800	Node1:Node2	ENABLE
disk	<u>Disk3</u>	stripe	Class1	Group1	sdc	8380800	Node1:Node2	ENABLE
disk	<u>Disk4</u>	stripe	Class1	Group1	sdd	8380800	Node1:Node2	ENABLE

OBJ	NAME	CLASS	DISKS	BLKS	FREEBLKS	SPARE
group	Group1	Class1	<u>Disk1:Disk2:Disk3:Disk4</u>	32964608	31850496	*

OBJ	NAME	CLASS	GROUP	SKIP	JRM	1STBLK	LASTBLK	BLOCKS	STATUS
volume	*	Class1	Group1	*	*	0	65535	65536	PRIVATE
volume	Volume1	Class1	Group1	*	*	<u>65536</u>	1114111	<u>1048576</u>	STOP
volume	*	Class1	Group1	*	*	1114112	32964607	31850496	FREE

OBJ	CLASS	GROUP	DISK	VOLUME	STATUS
slice	Class1	Group1	*	Volume1	STOP

If application volume Volume1 belongs to a stripe group, also pay attention to the stripe width.

```
# sdxinfo -G -c Class1 -o Group1 -e long
```

OBJ	NAME	CLASS	DISKS	BLKS	FREEBLKS	SPARE	MASTER	TYPE	WIDTH
group	Group1	Class1	Disk1:Disk2:Disk3:Disk4	32964608	31850496	*	*	stripe	<u>256</u>

12) Creating a shadow volume for restore

On backup server Node3, create a volume for restore (shadow volume) in the same configuration as the application volume found in step 11). The following settings are necessary on backup server Node3. A shadow volume for restore and a shadow volume for backup are common. When it has already been created, simply change the access mode as described in step 12-4).



Note

Application volume data may be damaged if data is written into a shadow volume in improper configuration. Be sure to confirm that the shadow volume configuration is proper in step 12-5).

12-1) Registering shadow disks

Register disks sda, sdb, sdc, and sdd with shadow class Class2, and name them Disk1, Disk2, Disk3, and Disk4 respectively.

```
# sdxshadowdisk -M -c Class2 -d sda=Disk1,sdb=Disk2,sdc=Disk3,sdd=Disk4
```



Point

- The disk names must correspond to the disk names assigned in step 1-1). The disk names assigned in 1-1) can be viewed in the NAME field for disk information displayed with the sdxinfo command in step 11).
- The class can be assigned any name.

12-2) Creating a shadow group

Connect shadow disks Disk1, Disk2, Disk3, and Disk4 to stripe type shadow group Group1.

```
# sdxshadowdisk -C -c Class2 -g Group1 -d Disk1,Disk2,Disk3,Disk4 -a type=stripe,width=256
```



Point

- If the application volume belongs to a stripe group or a concatenation group, the order of connecting shadow disks to a shadow group must correspond to the order of connecting disks to a group in step 1-2). The order of connecting disks in step 1-2) can be viewed in the DISKS field for group information displayed with the sdxinfo command in step 11).
- If the application volume belongs to a stripe group, the stripe width of a shadow group must correspond to the stripe width specified in step 1-2). The stripe width specified in step 1-2) can be viewed in the WIDTH field for group information displayed with the sdxinfo -e long command in step 11).
- The group can be assigned any name.

12-3) Creating a shadow volume

Create shadow volume Volume1 to Group1.

```
# sdxshadowvolume -M -c Class2 -g Group1 -v Volume1 -s 1048576
```



Point

- The volume must be created in the size corresponding to the volume size in step 1-3). The size of a volume created in step 1-3) can be viewed in the BLOCKS field for volume information displayed with the sdxinfo command in step 11).
- If there are multiple volumes, the corresponding shadow volumes must be created in the order of ascending values (first block numbers) in the 1STBLK field for volume information displayed with the sdxinfo command in step 11).
- The volume can be assigned any name.

12-4) Setting the access mode of the shadow volume

Activate shadow volume Volume1 in the read and write access mode (rw).

```
# sdxshadowvolume -F -c Class2 -v Volume1  
# sdxshadowvolume -N -c Class2 -v Volume1 -e mode=rw
```

12-5) Viewing the shadow volume configuration

Using the sdxinfo command, confirm that the group configuration and the volume configuration are proper based on group information in the DISKS field, volume information in the 1STBLK field and in the BLOCKS field and so on.

```
# sdxinfo -c Class2
```

OBJ	NAME	TYPE	SCOPE	SPARE
class	Class2	shared	Node3	0

OBJ	NAME	TYPE	CLASS	GROUP	DEVNAM	DEVBLKS	DEVCONNECT	STATUS
disk	Disk1	stripe	Class2	Group1	sda	8380800	Node3	ENABLE
disk	Disk2	stripe	Class2	Group1	sdb	8380800	Node3	ENABLE
disk	Disk3	stripe	Class2	Group1	sdc	8380800	Node3	ENABLE
disk	Disk4	stripe	Class2	Group1	sdd	8380800	Node3	ENABLE

OBJ	NAME	CLASS	DISKS	BLKS	FREEBLKS	SPARE
group	Group1	Class2	Disk1:Disk2:Disk3:Disk4	32964608	31850496	*

OBJ	NAME	CLASS	GROUP	SKIP	JRM	1STBLK	LASTBLK	BLOCKS	STATUS
volume	*	Class2	Group1	*	*	0	65535	65536	PRIVATE
volume	Volume1	Class2	Group1	*	*	65536	1114111	1048576	ACTIVE
volume	*	Class2	Group1	*	*	1114112	32964607	31850496	FREE

OBJ	CLASS	GROUP	DISK	VOLUME	STATUS
slice	Class2	Group1	*	Volume1	ACTIVE

For a stripe volume, see also the stripe width.

```
# sdxinfo -G -c Class2 -o Group1 -e long
```

OBJ	NAME	CLASS	DISKS	BLKS	FREEBLKS	SPARE	MASTER	TYPE	WIDTH
group	Group1	Class2	Disk1:Disk2:Disk3:Disk4	32964608	31850496	*	*	stripe	256

13) Restoring from tape

On backup server Node3, restore shadow volume data from tape to which it was backed up in step 6). In the following examples, restore data held in shadow volume Volume1 from a tape medium of tape device /dev/st0.



See

For details about the restore method, see manuals of a file system to be restored and used commands.



Information In a GFS Shared File System

Restore through the method as described in step 13a).

13a) When restoring data held in a raw device with the dd(1) command

```
# dd if=/dev/st0 of=/dev/sfdsk/Class2/rdisk/Volume1 bs=32768
```

13b) When restoring a ext3 file system with the tar(1) command

13b-1) Create a ext3 file system on Volume1.

```
# mkfs -t ext3 /dev/sfdsk/Class2/dsk/Volume1
```

13b-2) Mount the ext3 file system on shadow volume Volume1 on /mnt1, a temporary mount point.

```
# mkdir /mnt1
# mount -t ext3 /dev/sfdsk/Class2/dsk/Volume1 /mnt1
```

13b-3) Restore data held in the file system from tape.

```
# cd /mnt1
# tar xvf /dev/st0
```

13b-4) Unmount the file system mounted in step 13b-3).

```
# cd /
# umount /mnt1
# rmdir /mnt1
```

14) Removing the shadow volume

After the restore process is complete, remove the shadow volume to prevent improper access to it. The following procedure must be performed on backup server Node3.

14-1) Stopping the shadow volume

Stop shadow volume Volume1.

```
# sdxshadowvolume -F -c Class2 -v Volume1
```

14-2) Removing the shadow volume

Remove shadow volume Volume1.

```
# sdxshadowvolume -R -c Class2 -v Volume1
```

14-3) Removing the shadow group

Remove shadow group Group1.

```
# sdxshadowgroup -R -c Class2 -g Group1
```

14-4) Removing the shadow disks

Remove shadow disks Disk1, Disk2, Disk3, and Disk4.

```
# sdxshadowdisk -R -c Class2 -d Disk1  
# sdxshadowdisk -R -c Class2 -d Disk2  
# sdxshadowdisk -R -c Class2 -d Disk3  
# sdxshadowdisk -R -c Class2 -d Disk4
```

15) Resuming the services

Resume the services in the primary domain. The following procedure must be performed on the node that runs the services.

15-1) Activating the application volume

Activate application volume Volume1.

```
# sdxvolume -N -c Class1 -v Volume1
```

15-2) Resuming the services

When the file system on application volume Volume1 was unmounted in step 9), mount it again. Launch the applications that use Volume1.

6.3.2 Backing Up and Restoring through Snapshot by Slice Detachment

This sub-section describes the method of backing up data from and restoring data back to mirror volumes in the primary domain through a backup server in another domain.

6.3.2.1 System Configuration

Figure: System Configuration

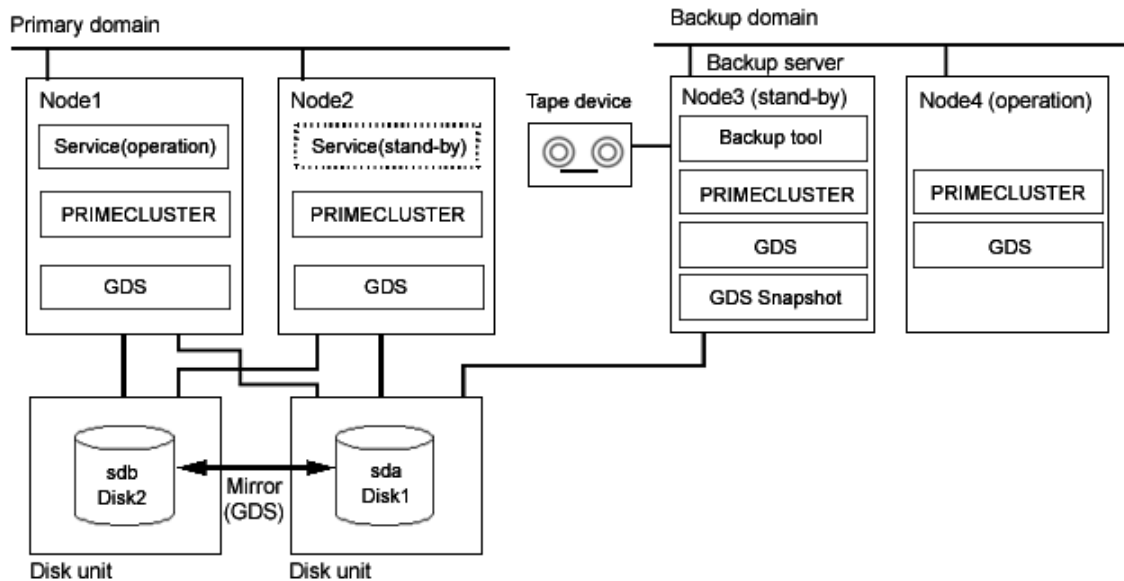

Note Physical Device Name

Different physical device names (such as sda) may be assigned to the identical physical disk in the primary domain and the backup server.

Figure: Object Configuration in Normal Operation

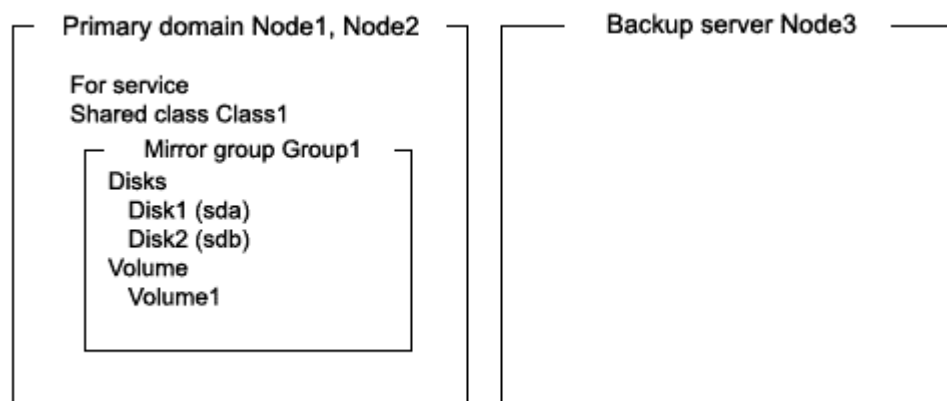

6.3.2.2 Summary of Backup

Data in a slice temporarily detached from a volume can be backed up to tape during the service operation.

To secure consistency of data in a detached slice, the services must be stopped temporarily when detaching the slice.



Information Consistency of Snapshot Data

When detaching a slice while the services are operating, data consistency must be secured through the method specific to that software, such as a file system and a database system, which manages volume data. For details, see "A.2.15 Ensuring Integrity of Snapshot Data."

Figure: Backup

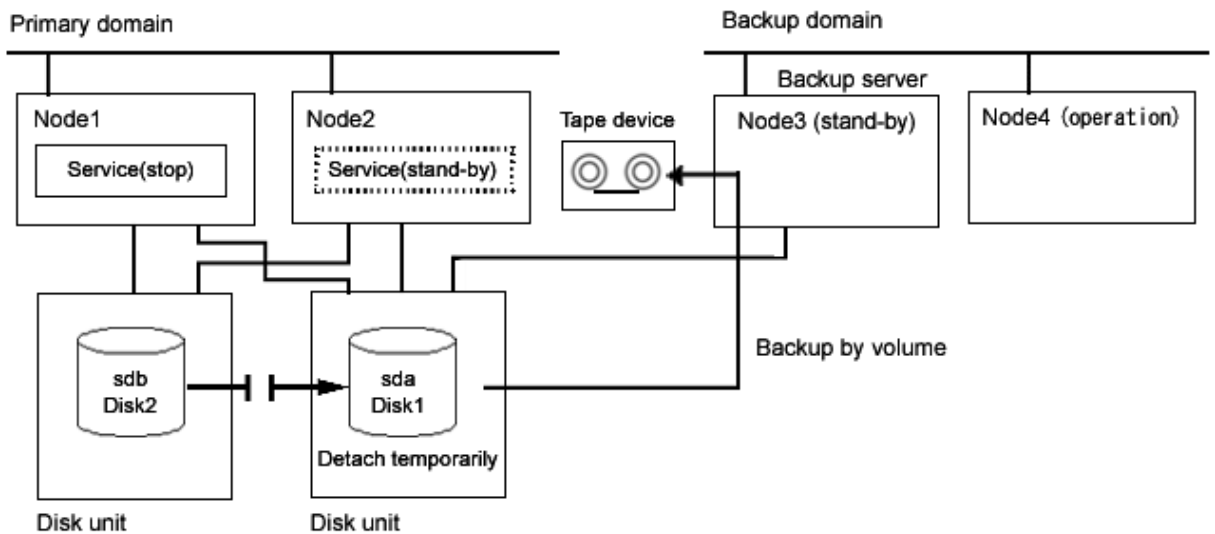

Figure: Object Configuration When Backing Up

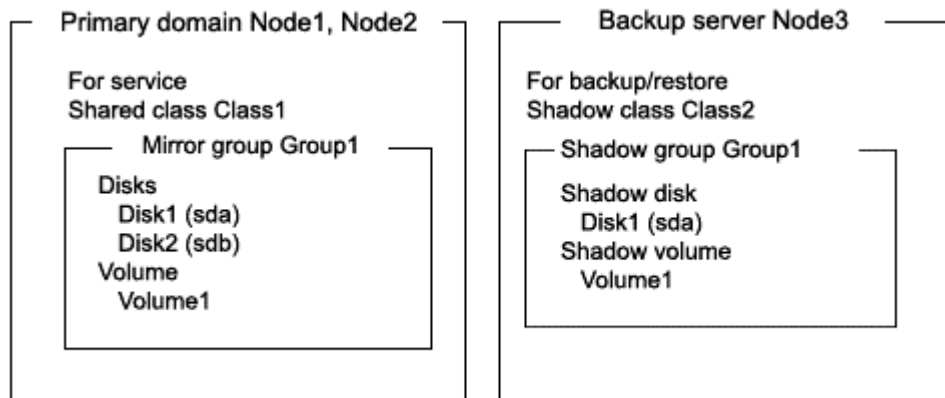
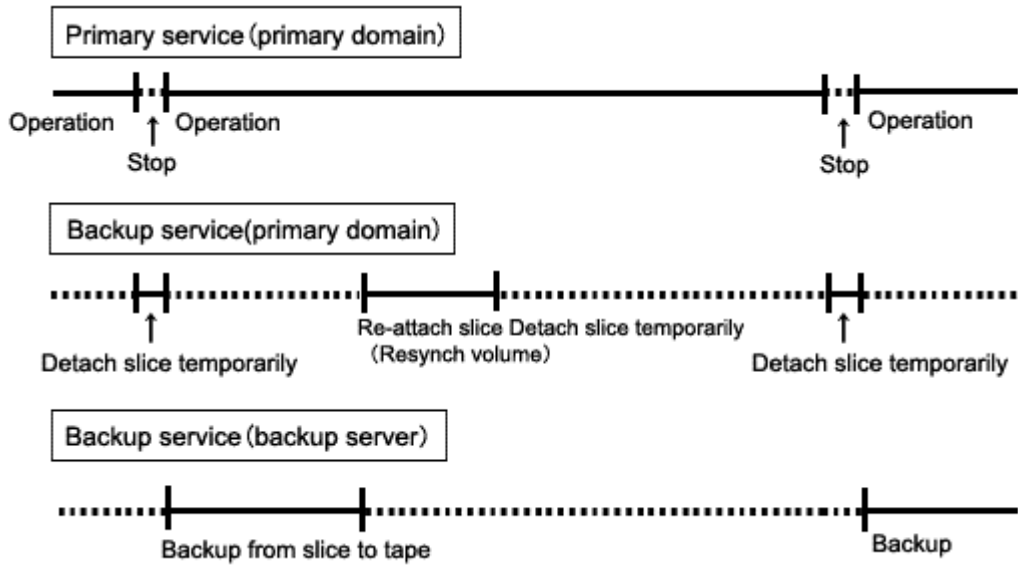

Figure: Backup Schedule



6.3.2.3 Summary of Restore

If volume data is damaged, it can be restored from tape. Data can be restored while service is stopped and the application volume is not in use.

Figure: Restore

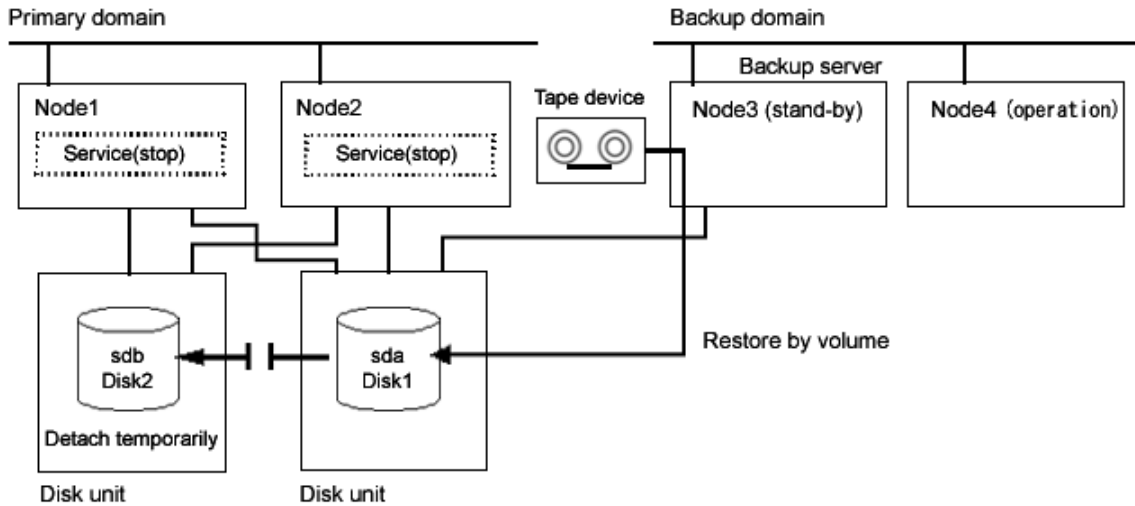

Information

In this configuration access cannot be gained from backup server Node3 to disk sdb. Therefore, after data is restored from tape back to sda while sdb is detached temporarily, resynchronization copying from sda to sdb must be performed by re-attaching sdb. When access can be gained from Node3 to both sda and sdb, it is not required that sdb be detached temporarily since data can be restored from tape back to both sda and sdb. For details about this restore method, see "6.3.1 Backing Up and Restoring a Logical Volume with No Replication."

Figure: Object Configuration When Restoring

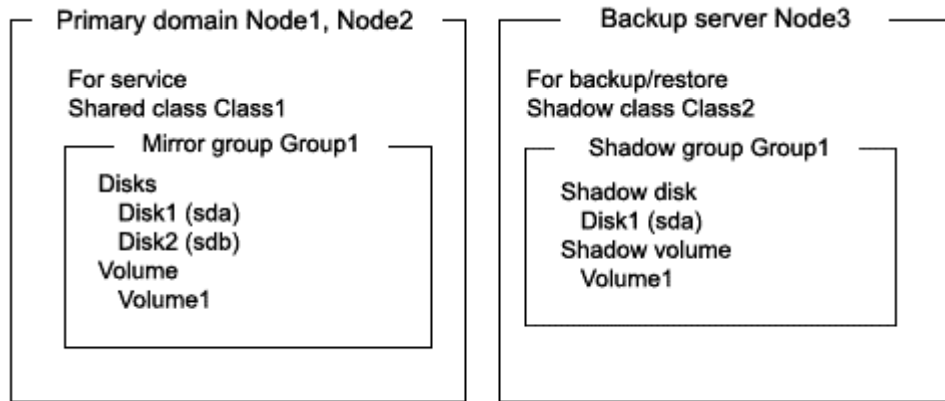
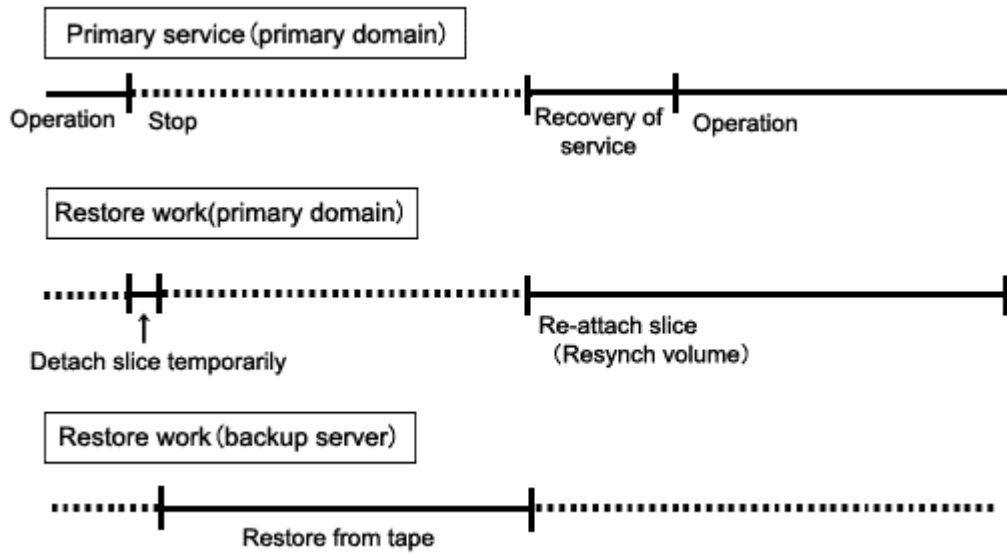

Figure: Restore Schedule



6.3.2.4 Summary of Procedure

Figure: Outline of the Configuration Procedure



Figure: Outline of the Backup Procedure

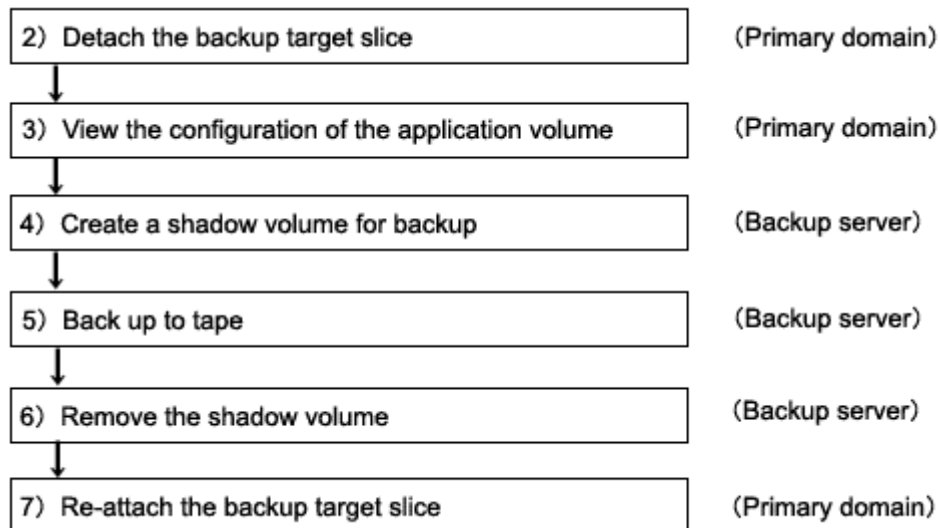
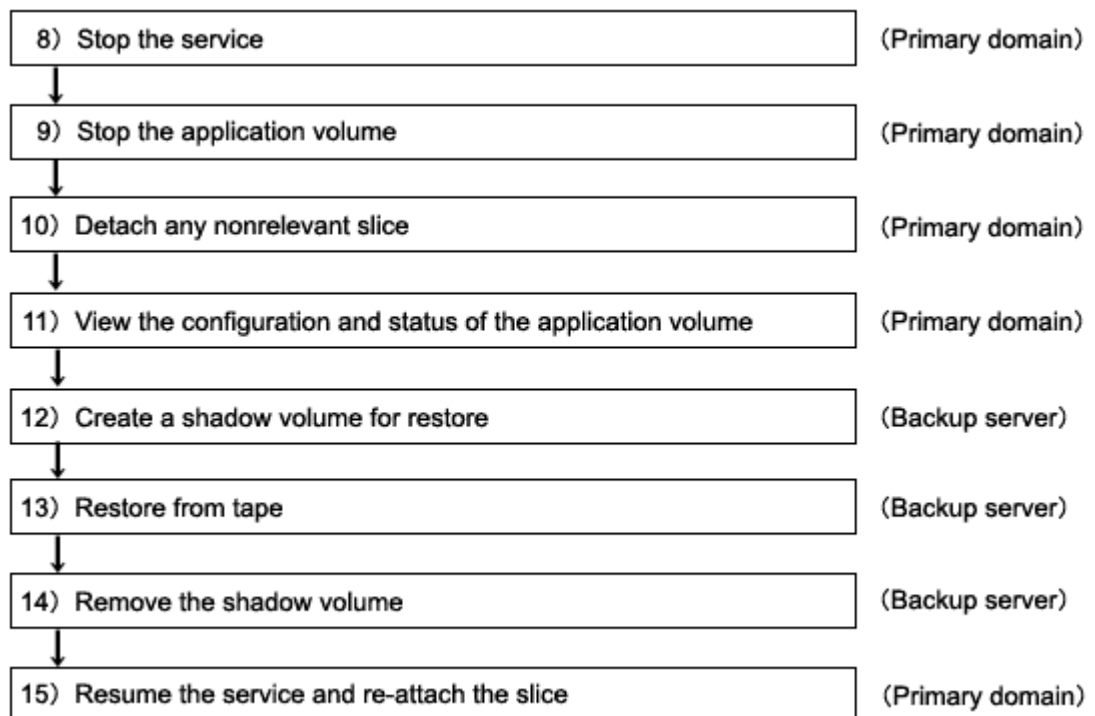

Figure: Outline of the Restore Procedure



6.3.2.5 Configuring an Environment



Note Automatic Resource Registration

Disks that are registered as resources in the primary domain or are to be registered with a shadow class in the backup domain may not be involved in the resource registration in the backup domain. For details about the automatic resource registration, see "Appendix H Register shared disk units."

1) Creating an application volume

Create a mirror volume used for the services on disks sda and sdb. The following settings are necessary on Node1 or Node2 in the primary domain.

1-1) Registering disks

Register disks sda and sdb with shared class Class1 that is shared on Node1 and Node2, and name them Disk1 and Disk2 respectively.

```
# sdxdisk -M -c Class1 -a type=shared,scope=Node1:Node2 -d  
sda=Disk1,sdb=Disk2
```

1-2) Creating a mirror group

Connect Disk1 and Disk2 to mirror group Group1.

```
# sdxdisk -C -c Class1 -g Group1 -d Disk1,Disk2
```

1-3) Creating a mirror volume

Create mirror volume Volume1 to mirror group Group1.

```
# sdxvolume -M -c Class1 -g Group1 -v Volume1 -s 1048576
```

6.3.2.6 Backing Up

2) Detaching the backup target slice

Temporarily detach the slice on Disk1 that is the backup target, among slices in application volume Volume1. The following procedure must be performed on Node1 or Node2 in the primary domain.



Information

The following example secures data consistency by stopping the services when a slice is detached. Steps 2-1) and 2-3) are not required if your software, such as a file system and a database system, that manages volume data provides functionality ensuring data consistency or repairing consistency for a detached slice. Alternatively, data consistency must be secured with the method specific to that software. For details, see "A.2.15 Ensuring Integrity of Snapshot Data."

2-1) Stopping the services

To secure consistency of data in a detached slice, exit all applications accessing application volume Volume1 on Node1 and Node2.

When Volume1 is used as a file system, it should be unmounted.

2-2) Detaching the slice

Temporarily detach the slice on disk Disk1 from Volume1. To write-lock the detached slice, set the access mode of the slice to ro (read only).

```
# sdxslice -M -c Class1 -d Disk1 -v Volume1 -a jrm=off,mode=ro
```



Note Just Resynchronization Mode for Silice

On backup server Node3, data may be written from Node3 into Disk1 when data in Disk1 is backed up to tape. GDS in the primary domain cannot recognize the write occurrence from Node3. Consequently, if the JRM mode of the detached slice is "on", the portions updated from Node3 may not be involved in resynchronization copying performed when the slice is re-attached. If this happens, synchronization of Volume1 is no longer ensured. For this reason, the JRM mode of a detached slice must be set to off in advance.

2-3) Resuming the services

When the file system was unmounted in step 2-1), mount it again.
Launch the applications exited in step 2-1).

3) Viewing the configuration of the application volume

On Node1 or Node2 in the primary domain, view the configuration of application volume Volume1 that is the backup target.

```
# sdxinfo -c Class1
OBJ  NAME  TYPE  SCOPE  SPARE
-----
class Class1 shared Node1:Node2 0

OBJ  NAME  TYPE  CLASS  GROUP  DEVNAM  DEVBLKS  DEVCONNECT  STATUS
-----
disk Disk1 mirror Class1 Group1 sda      8380800  Node1:Node2  ENABLE
disk Disk2  mirror Class1 Group1 sdb      8380800  Node1:Node2  ENABLE

OBJ  NAME  CLASS  DISKS  BLKS  FREEBLKS  SPARE
-----
group Group1 Class1 Disk1:Disk2 8290304 7176192 0

OBJ  NAME  CLASS  GROUP  SKIP  JRM  1STBLK  LASTBLK  BLOCKS  STATUS
-----
volume *      Class1 Group1 *      *      0      65535  65536  PRIVATE
volume Volume1 Class1 Group1 off    on    65536 1114111 1048576 ACTIVE
volume *      Class1 Group1 *      *      1114112 8290303 7176192 FREE

OBJ  CLASS  GROUP  DISK  VOLUME  STATUS
-----
slice Class1 Group1 Disk1 Volume1 TEMP
slice Class1 Group1 Disk2  Volume1 ACTIVE
```

4) Creating a shadow volume for backup

Create a volume for backup (shadow volume) to disk sda on backup server Node3. The following settings are necessary on backup server Node3.



Note

Application volume data may be damaged if data is written into a shadow volume in improper configuration. Be sure to confirm that the shadow volume configuration is proper in step 4-4).

4-1) Registering a shadow disk

Register disk sda with shadow class Class2, and name it Disk1.

```
# sdxshadowdisk -M -c Class2 -d sda=Disk1
```



Point

- The disk name must correspond to the disk name assigned to disk sda in step 1-1). The disk names assigned in 1-1) can be viewed in the NAME field for disk information displayed with the sdxinfo command in step 3).
- The class can be assigned any name.

4-2) Creating a shadow group

Connect shadow disk Disk1 to mirror type shadow group Group1.

```
# sdxshadowdisk -C -c Class2 -g Group1 -d Disk1
```

4-3) Creating a shadow volume

Create shadow volume Volume1 to shadow group Group1.

```
# sdxshadowvolume -M -c Class2 -g Group1 -v Volume1 -s 1048576
```



Point

- The volume must be created in the size corresponding to the volume size in step 1-3). The size of a volume created in step 1-3) can be viewed in the BLOCKS field for volume information displayed with the `sdxinfo` command in step 3).
- If there are multiple volumes, the corresponding shadow volumes must be created in the order of ascending values (first block numbers) in the 1STBLK field for volume information displayed with the `sdxinfo` command in step 3).
- The volume can be assigned any name.

4-4) Viewing the configuration of the shadow volume

Using the `sdxinfo` command, confirm that the group configuration and the volume configuration are proper based on group information in the DISKS field, volume information in the 1STBLK field and in the BLOCKS field and so on.

```
# sdxinfo -c Class2
OBJ  NAME  TYPE  SCOPE  SPARE
-----
class Class2 shared Node3      0

OBJ  NAME  TYPE  CLASS  GROUP  DEVNAM  DEVBLKS  DEVCONNECT  STATUS
-----
disk Disk1 mirror Class2 Group1  sda      8380800  Node3      ENABLE

OBJ  NAME  CLASS  DISKS  BLKS  FREEBLKS  SPARE
-----
group Group1 Class2 Disk1 8290304 7176192      0

OBJ  NAME  CLASS  GROUP  SKIP  JRM  1STBLK  LASTBLK  BLOCKS  STATUS
-----
volume *      Class2 Group1 *      *      0      65535  65536  PRIVATE
volume Volume1 Class2 Group1 off    off    65536 1114111 1048576 ACTIVE
volume *      Class2 Group1 *      *      1114112 8290303 7176192  FREE

OBJ  CLASS  GROUP  DISK  VOLUME  STATUS
-----
slice Class2 Group1 Disk1 Volume1 ACTIVE
```

5) Backing up to tape

On backup server Node3, back up data in the shadow volume to tape. The following shows examples of backing up data in shadow volume Volume1 to a tape medium of tape device `/dev/st0`.



See

For details about the backup method, see manuals of a file system to be backed up and used command.

5a) When backing up data held in a raw device with the `dd(1)` command

```
# dd if=/dev/sfdsk/Class2/rdisk/Volume1 of=/dev/st0 bs=32768
```

5b) When backing up a ext3 file system with the `tar(1)` command

5b-1) Activate shadow volume Volume1 in the read and write access mode (rw).

```
# sdxshadowvolume -F -c Class2 -v Volume1
# sdxshadowvolume -N -c Class2 -v Volume1 -e mode=rw
```

5b-2) Check and repair consistency of the ext3 file system on shadow volume Volume1. If the file system was unmounted when the slice was detached in step 2), this step can be skipped.

```
# fsck -t ext3 -y /dev/sfdsk/Class2/dsk/Volume1
```

5b-3) Mount the ext3 file system on shadow volume Volume1 on `/mnt1`, a temporary mount point, in the read only mode.

```
# mkdir /mnt1
# mount -t ext3 -o ro /dev/sfdsk/Class2/dsk/Volume1 /mnt1
```

5b-4) Back up data held in the file system to tape.

```
# cd /mnt1
# tar cvf /dev/rmt/0 .
```

5b-5) Unmount the file system mounted in step 5b-3).

```
# cd /
# umount /mnt1
# rmdir /mnt1
```

6) Removing the shadow volume

After the backup process is complete, remove the shadow volume to prevent improper access to it. The following procedure must be performed on backup server Node3.

6-1) Stopping the shadow volume

Stop shadow volume Volume1.

```
# sdxshadowvolume -F -c Class2 -v Volume1
```

6-2) Removing the shadow volume

Remove shadow volume Volume1.

```
# sdxshadowvolume -R -c Class2 -v Volume1
```

6-3) Removing the shadow group

Remove shadow group Group1.

```
# sdxshadowgroup -R -c Class2 -g Group1
```

6-4) Removing the shadow disk

Remove shadow disk Disk1.

```
# sdxshadowdisk -R -c Class2 -d Disk1
```

7) Re-attaching the backup target slice

Re-attach the slice temporarily detached from the application volume back to it. The following procedure must be performed on Node1 or Node2 in the primary domain.

7-1) Re-attaching the backup target slice

Re-attach slice Volume1.Disk1 temporarily detached from application volume Volume1 in step 2-2).

```
# sdxslice -R -c Class1 -d Disk1 -v Volume1
```

After returning from the command, synchronization copying from the slice on Disk2 to the slice on Disk1 in Volume1 is executed.

7-2) Viewing the copy status

The status of synchronization copying can be viewed using the `sdxinfo -S` command. The copy destination slice is in the COPY status if copying is in progress and it will be in the ACTIVE status after the copy process ends normally (note, however, that it will be in the STOP status when Volume1 is in the STOP status).

```
# sdxinfo -S -c Class1 -o Volume1
OBJ CLASS GROUP DISK VOLUME STATUS
-----
slice Class1 Group1 Disk1 Volume1 ACTIVE
slice Class1 Group1 Disk2 Volume1 COPY
```

6.3.2.7 Restoring



Information If access can be gained from backup server Node3 to all of the disks constituting Volume1 (sda and sdb)

Data can be restored from tape back to both sda and sdb on Node3. Under these circumstances, detaching a slice should not be performed as described in step 10).

8) Stopping the services

Exit all applications using application volume Volume1 on Node1 and Node2 in the primary domain. When Volume1 is used as a file system, it should be unmounted.

9) Stopping the application volume

To write-lock volume Volume1, inactivate Volume1 on Node1 and Node2 in the primary domain. Execute the following command on Node1 or Node2.

```
# sdxvolume -F -c Class1 -v Volume1 -e allnodes
```

10) Detaching any nonrelevant slice from the application volume

Temporarily detach the slice on any disk (Disk2) other than Disk1 that is the restore target from Volume1, among slices in application volume Volume1. Execute the following command on Node1 or Node2 in the primary domain.

```
# sdxslice -M -c Class1 -d Disk2 -v Volume1 -a jrm=off
```



Note Just Resynchronization Mode for Slice

On backup server Node3, after data is restored from tape back to Disk1, the slice on Disk2 is supposed to be re-attached to application volume Volume1 in the primary domain. At this point the entire volume data must be copied to the attached slice. For this reason, the JRM mode of a detached slice must be set to off in advance.



Information If access can be gained from backup server Node3 to all of the disks constituting Volume1 (sda and sdb)

This procedure (detaching a slice) should not be performed.

11) Viewing the configuration and status of the application volume

On Node1 or Node2 in the primary domain, view the configuration and status of application volume Volume1 that is the restore target. Confirm that Volume1 is in STOP status and that only restore target slice Volume1.Disk1 is in STOP status among the slices constituting the volume and the other slices are in TEMP or TEMP-STOP status. If the volume or slice status is improper, repair it referencing to “F.1.3 Volume Status Abnormality” and “F.1.1 Slice Status Abnormality.”

```
# sdxinfo -c Class1
OBJ NAME TYPE SCOPE SPARE
-----
class Class1 shared Node1:Node2 0

OBJ NAME TYPE CLASS GROUP DEVNAM DEVBLKS DEVCONNECT STATUS
-----
disk Disk1 mirror Class1 Group1 sda 8380800 Node1:Node2 ENABLE
disk Disk2 mirror Class1 Group1 sdb 8380800 Node1:Node2 ENABLE

OBJ NAME CLASS DISKS BLKS FREEBLKS SPARE
-----
group Group1 Class1 Disk1:Disk2 8290304 7176192 0

OBJ NAME CLASS GROUP SKIP JRM 1STBLK LASTBLK BLOCKS STATUS
-----
volume * Class1 Group1 * * 0 65535 65536 PRIVATE
volume Volume1 Class1 Group1 off on 65536 1114111 1048576 STOP
volume * Class1 Group1 * * 1114112 8290303 7176192 FREE

OBJ CLASS GROUP DISK VOLUME STATUS
-----
slice Class1 Group1 Disk1 Volume1 STOP
slice Class1 Group1 Disk2 Volume1 TEMP
```



Information If access can be gained from backup server Node3 to all of the disks constituting Volume1 (sda and sdb)

You must confirm that all of the slices of Volume1 are in STOP status.

12) Creating a shadow volume for restore

On backup server Node3, create a volume for restore (shadow volume) on disk sda. The following settings are necessary on backup server Node3. A shadow volume for restore and a shadow volume for backup are common. If one already exists, this procedure is not required.



Note

Application volume data may be damaged if data is written into a shadow volume in improper configuration. Be sure to confirm that the shadow volume configuration is proper in step 12-5).



Information If access can be gained from backup server Node3 to all of the disks constituting Volume1 (sda and sdb)

A shadow volume for restore must be created in the same configuration as Volume1. Under these circumstances, those shadow volumes for restore and backup are not common.

12-1) Registering a shadow disk

Register disk sda with shadow class Class2, and name it Disk1.

```
# sdxshadowdisk -M -c Class2 -d sda=Disk1
```



Point

- The disk name must correspond to the disk name assigned to sda in step 1-1). The disk names assigned in 1-1) can be viewed in the NAME field for disk information displayed with the sdxinfo command in step 3).
- The class can be assigned any name.



Information If access can be gained from backup server Node3 to all of the disks constituting Volume1 (sda and sdb)

All of those disks (sda and sdb) must be registered with a shadow class.

12-2) Creating a shadow group

Connect shadow disk Disk1 to mirror type shadow group Group1.

```
# sdxshadowdisk -C -c Class2 -g Group1 -d Disk1
```



Information If access can be gained from backup server Node3 to all of the disks constituting Volume1 (sda and sdb)

All of those disks (sda and sdb) must be connected to a shadow group.

12-3) Creating a shadow volume

Create shadow volume Volume1 to shadow group Group1.

```
# sdxshadowvolume -M -c Class2 -g Group1 -v Volume1 -s 1048576
```



Point

- The volume must be created in the size corresponding to the volume size in step 1-3). The size of a volume created in step 1-3) can be viewed in the BLOCKS field for volume information displayed with the sdxinfo command in step 11).
- If there are multiple volumes, the corresponding shadow volumes must be created in the order of ascending values (first block numbers) in the 1STBLK field for volume information displayed with the sdxinfo command in step 11).
- The volume can be assigned any name.

12-4) Setting the access mode of the shadow volume

Activate shadow volume Volume1 in the read and write access mode (rw).

```
# sdxshadowvolume -F -c Class2 -v Volume1  
# sdxshadowvolume -N -c Class2 -v Volume1 -e mode=rw
```

12-5) Viewing the configuration of the shadow volume

Using the sdxinfo command, confirm that the group configuration and the volume configuration are proper based on group information in the DISKS field, volume information in the 1STBLK field and in the BLOCKS field and so on.

```
# sdxinfo -c Class2  
OBJ  NAME  TYPE  SCOPE  SPARE  
-----  
class Class2 shared Node3      0  
  
OBJ  NAME  TYPE  CLASS  GROUP  DEVNAM  DEVBLKS  DEVCONNECT  STATUS  
-----  
disk Disk1 mirror Class2 Group1  sda      8380800  Node3      ENABLE  
  
OBJ  NAME  CLASS  DISKS  BLKS  FREEBLKS  SPARE  
-----  
group Group1 Class2 Disk1 8290304 7176192  0  
  
OBJ  NAME  CLASS  GROUP  SKIP  JRM  1STBLK  LASTBLK  BLOCKS  STATUS  
-----  
volume *      Class2 Group1 *      *      0      65535  65536  PRIVATE  
volume Volume1 Class2 Group1 off    off    65536 1114111 1048576 ACTIVE  
volume *      Class2 Group1 *      *      1114112 8290303 7176192  FREE  
  
OBJ  CLASS  GROUP  DISK  VOLUME  STATUS  
-----  
slice Class2 Group1 Disk1 Volume1  ACTIVE
```

13) Restoring from tape

On backup server Node3, restore shadow volume data from tape to which it was backed up in step 5). In the following examples, restore data held in shadow volume Volume1 from a tape medium of tape device /dev/st0.



See

For details about the restore method, see manuals of a file system to be restored and used commands.

13a) When restoring data held in a raw device with the dd(1) command

```
# dd if=/dev/st0 of=/dev/sfdsk/Class2/rdisk/Volume1 bs=32768
```

13b) When restoring a ext3 file system with the tar(1) command

13b-1) Create a ext3 file system to shadow volume Volume1.

```
# mkfs -t ext3 /dev/sfdsk/Class2/dsk/Volume1
```

13b-2) Mount the ext3 file system on shadow volume Volume1 on /mnt1, a temporary mount point.

```
# mkdir /mnt1  
# mount -t ext3 /dev/sfdsk/Class2/dsk/Volume1 /mnt1
```

13b-3) Restore data held in the file system from tape.

```
# cd /mnt1  
# tar xvf /dev/st0
```

13b-4) Unmount the file system mounted in step 13b-3).

```
# cd /  
# umount /mnt1  
# rmdir /mnt1
```

14) Removing the shadow volume

After the restore process is complete, remove the shadow volume to prevent improper access to it. The following procedure must be performed on backup server Node3.

14-1) Stopping the shadow volume

Stop shadow volume Volume1.

```
# sdxshadowvolume -F -c Class2 -v Volume1
```

14-2) Removing the shadow volume

Remove shadow volume Volume1.

```
# sdxshadowvolume -R -c Class2 -v Volume1
```

14-3) Removing the shadow group

Remove shadow group Group1.

```
# sdxshadowgroup -R -c Class2 -g Group1
```

14-4) Removing the shadow disk

Remove shadow disk Disk1.

```
# sdxshadowdisk -R -c Class2 -d Disk1
```



Information If access can be gained from backup server Node3 to all of the disks constituting Volume1 (sda and sdb)

All of the disks registered with shadow class Class2 in step 12) (sda and sdb) must be removed.

15) Resuming the services and re-attaching the slice to the application volume

Resume service in the primary domain. The following procedure should be performed on the node that runs the services.



Information

In the following example resuming the services is put above resynchronizing the application volume. Through this procedure the service is resumed first and then resynchronization of the volume is secured during the services operation. If resynchronizing the volume should be put above resuming the services, the procedure should be followed in the order of steps 15-1), 15-3), 15-4) (confirming that the synchronization copying is complete), and 15-2).

15-1) Activating the application volume
Activate application volume Volume1.

```
# sdxvolume -N -c Class1 -v Volume1
```

15-2) Resuming the services

When the file system on application volume Volume1 was unmounted in step 8), mount it again.
Launch the applications that use Volume1.

15-3) Re-attaching the slice to the application volume

Re-attach slice Volume1.Disk2 that was temporarily detached from application volume Volume1 in step 10) back to Volume1.

```
# sdxslice -R -c Class1 -d Disk2 -v Volume1
```

After returning from the command, synchronization copying from the slice on Disk1 to the slice on Disk2 in Volume1 is executed.

15-4) Viewing the copy status

The status of synchronization copying can be viewed using the `sdxinfo -S` command. The copy destination slice is in COPY status if copying is in progress and it will be in ACTIVE status after the copy process ends normally (note, however, that it will be in STOP status when Volume1 is in STOP status).

```
# sdxinfo -S -c Class1 -o Volume1
```

```
OBJ CLASS GROUP DISK VOLUME STATUS
```

```
-----
```

```
slice Class1 Group1 Disk1 Volume1 ACTIVE
```

```
slice Class1 Group1 Disk2 Volume1 COPY
```

6.3.3 Backing Up and Restoring Using Snapshots from a Proxy Volume

This sub-section describes the method of backing up data from and restoring data back to logical volumes in the primary domain through a backup server in another domain by use of snapshots from the proxy volume.

6.3.3.1 System Configuration

Figure: System Configuration

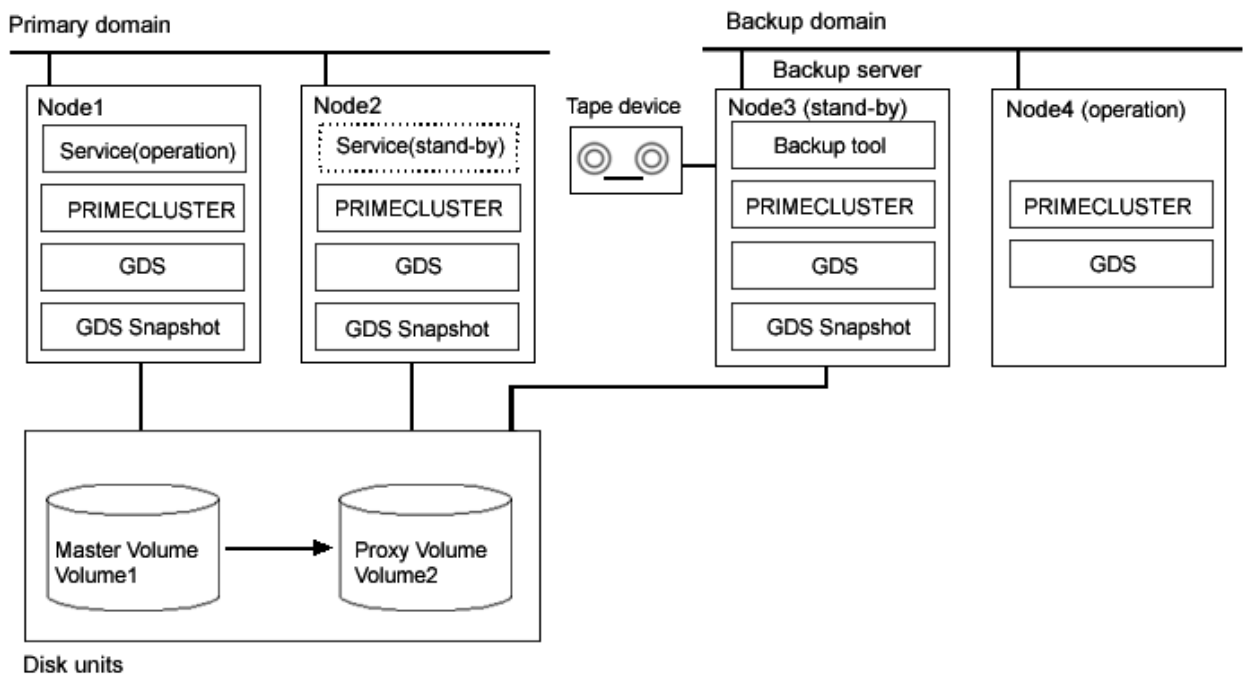
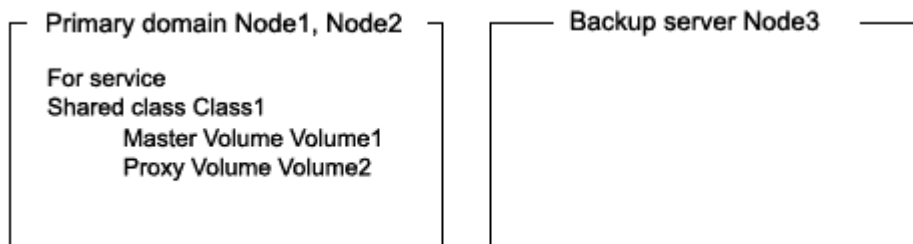

Figure: Object Configuration in Normal Operation



6.3.3.2 Summary of Backup

Data in a proxy volume parted from the master volume during the services operation can be backed up to tape.

To secure consistency of data in the proxy volume to be parted, the services should be stopped temporarily when it is parted.



Information Consistency of Snapshot Data

When detaching a proxy volume while the service is operating, data consistency must be secured through the method specific to that software, such as a file system and a database system, which manages volume data. For details, see "A.2.15 Ensuring Integrity of Snapshot Data."

Figure: Backup

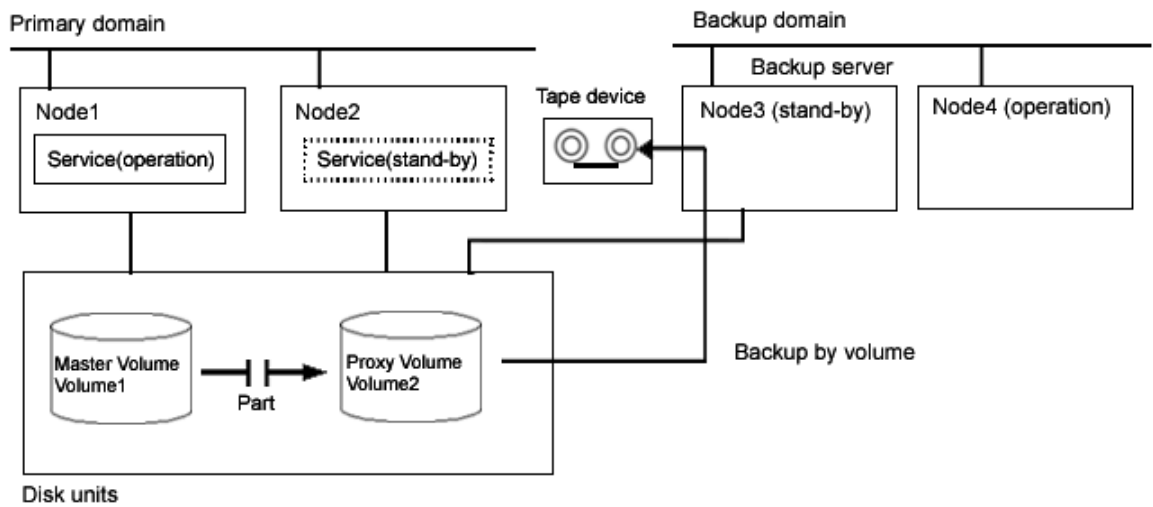

Figure: Object Configuration When Backing Up

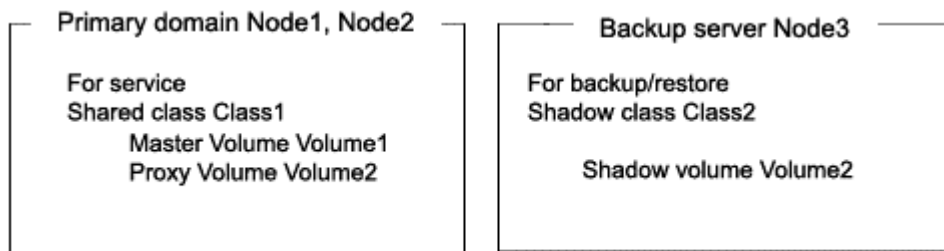
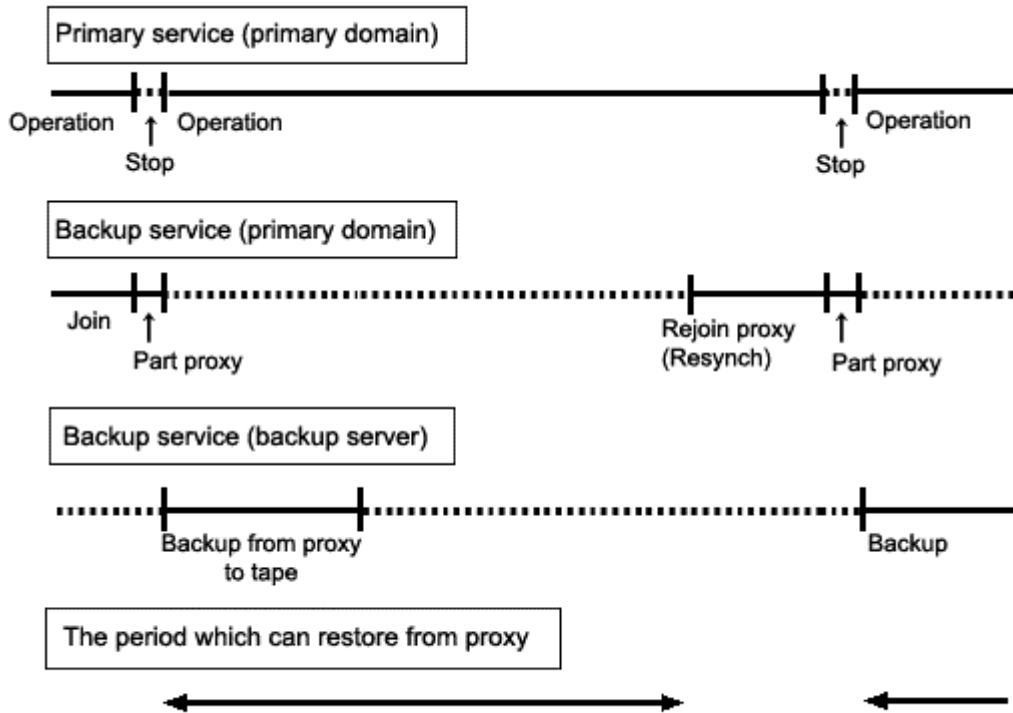

Figure: Backup Schedule



6.3.3.3 Summary of Restore from a Proxy Volume

If master volume data is damaged while a proxy volume is parted from the master volume used for the services operation, data can be restored from the proxy volume back to the master volume.

When restoring, access to the volume must be suspended temporarily.

Figure: Restore from a Proxy Volume

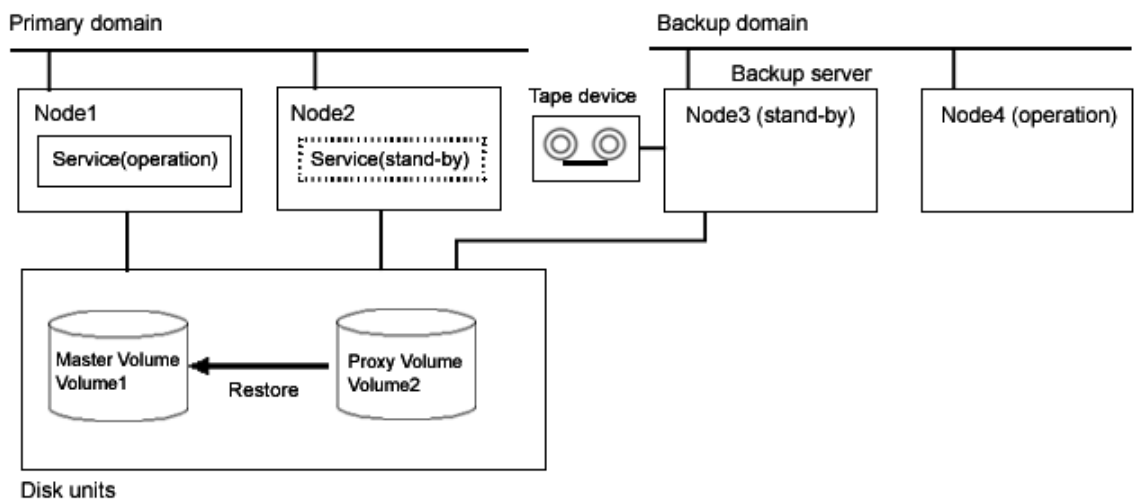

Figure: Object Configuration When Restoring from a Proxy Volume

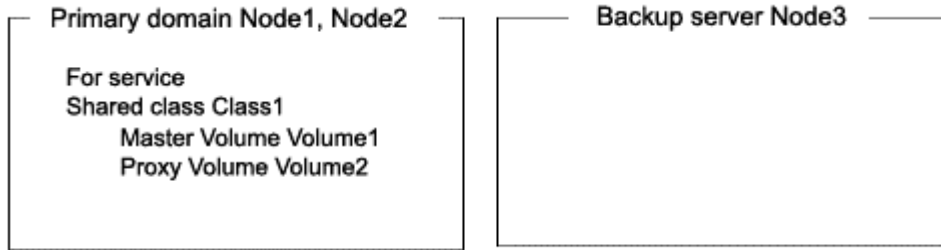
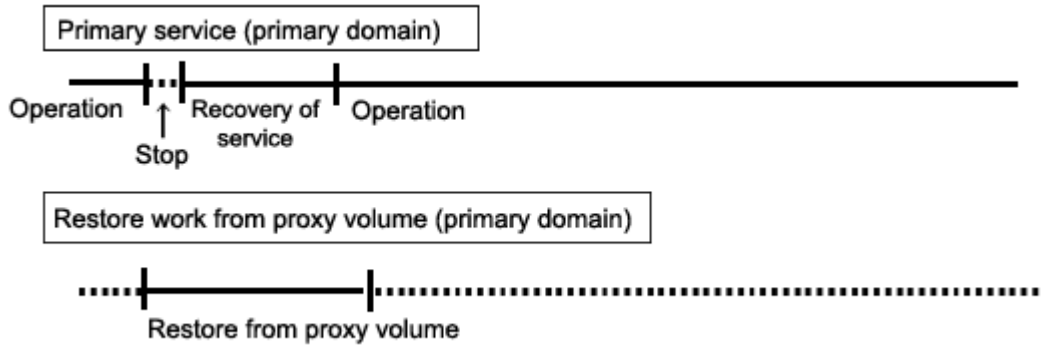

Figure: Schedule for Restore a Proxy Volume



6.3.3.4 Summary of Restore from Tape

If master volume data is damaged while the master volume for the services operation and the proxy volume are in the joined state, the proxy data is also damaged. In this case data can be restored from tape back to the master volume.

Data can be restored while the service is stopped and the master volume is not in use.

Figure: Restore from Tape

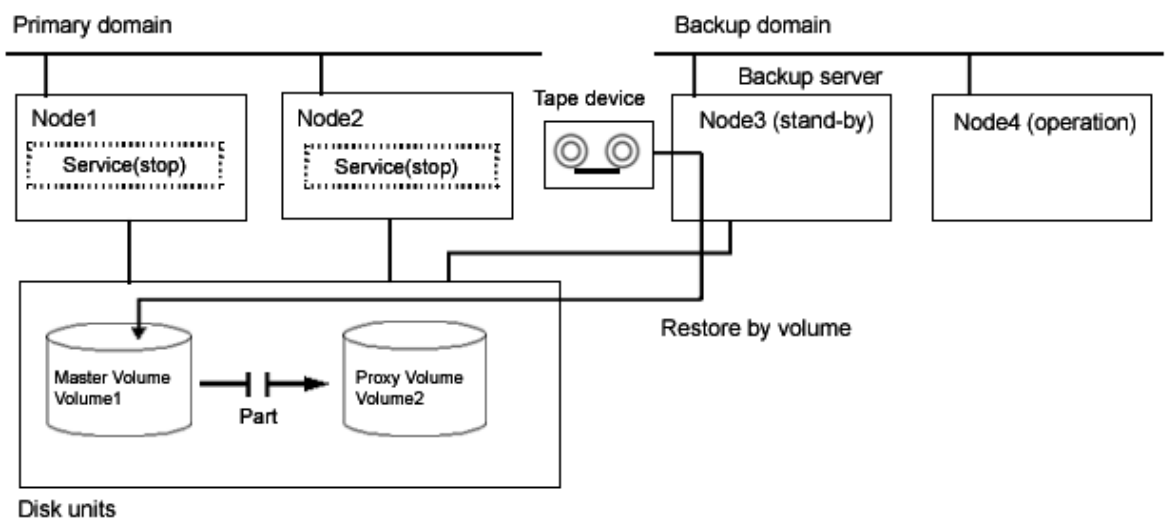



Information

This sub-section shows an example when access can be gained from backup server Node3 to all of the disks constituting master volume Volume1.



Information

When access can be gained from backup server Node3 to all of the disks constituting master volume Volume1 and the disk unit's copy function is used to synchronize a master and a proxy, parting proxy volume Volume2 is not required to restore data from tape.



Information

When access cannot be gained from the backup server to the disks constituting the master volume, while proxy volume Volume2 is parted, copy data from tape to the proxy volume, and then restore master volume data using the proxy volume.

Figure: Object Configuration When Restoring from Tape

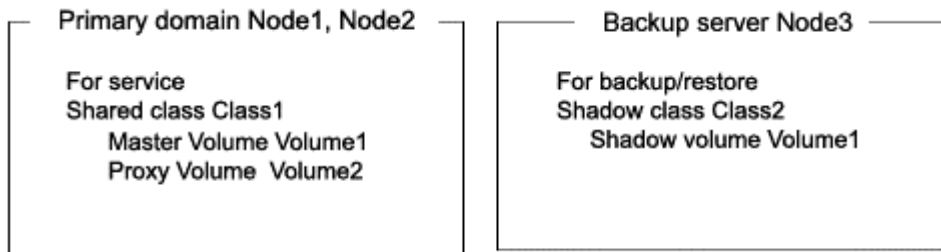
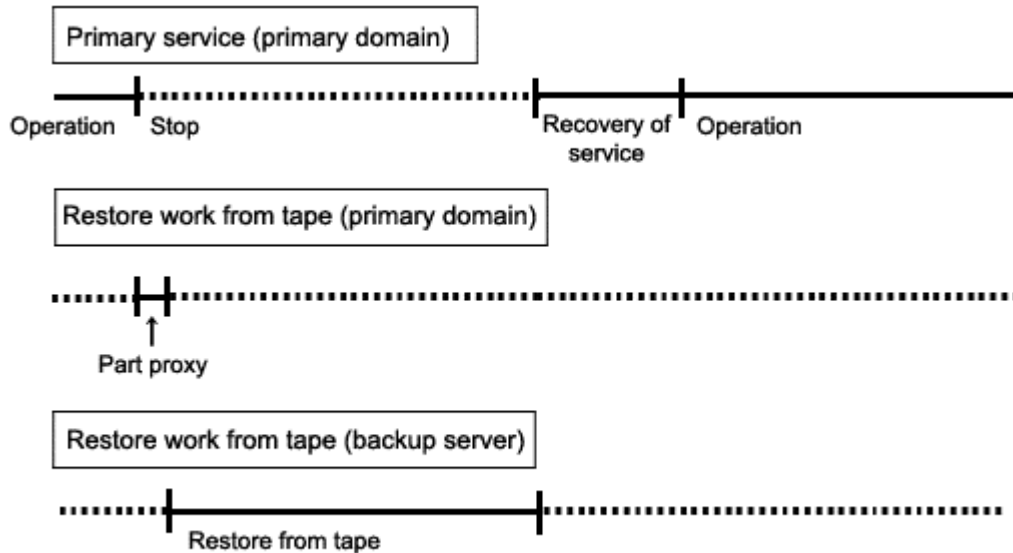

Figure: Schedule for Restore from Tape



6.3.3.5 Summary of Procedure

Figure: Outline of the Configuration Procedure

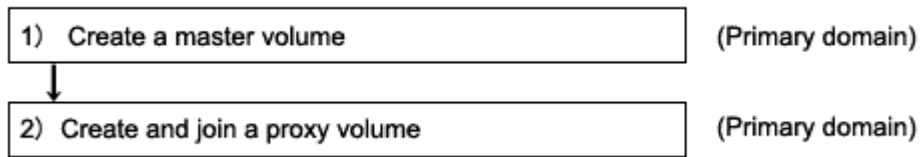

Figure: Outline of the Backup Procedure

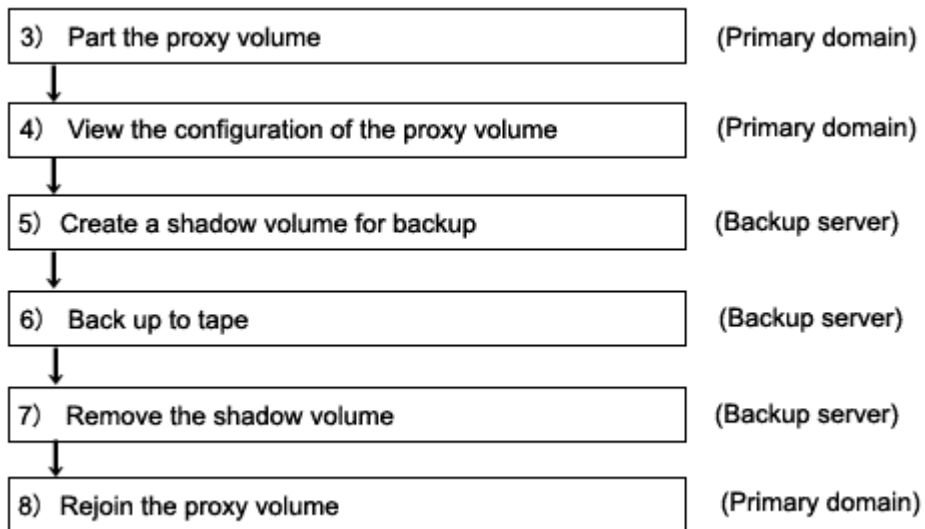

Figure: Outline of the Procedure for Restoring from a Proxy Volume

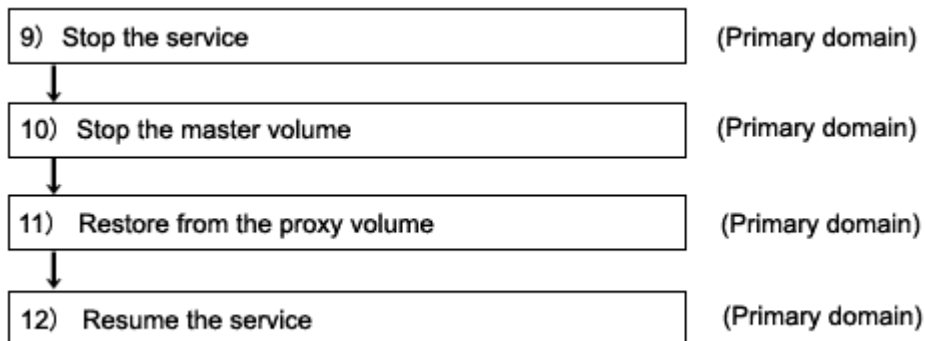
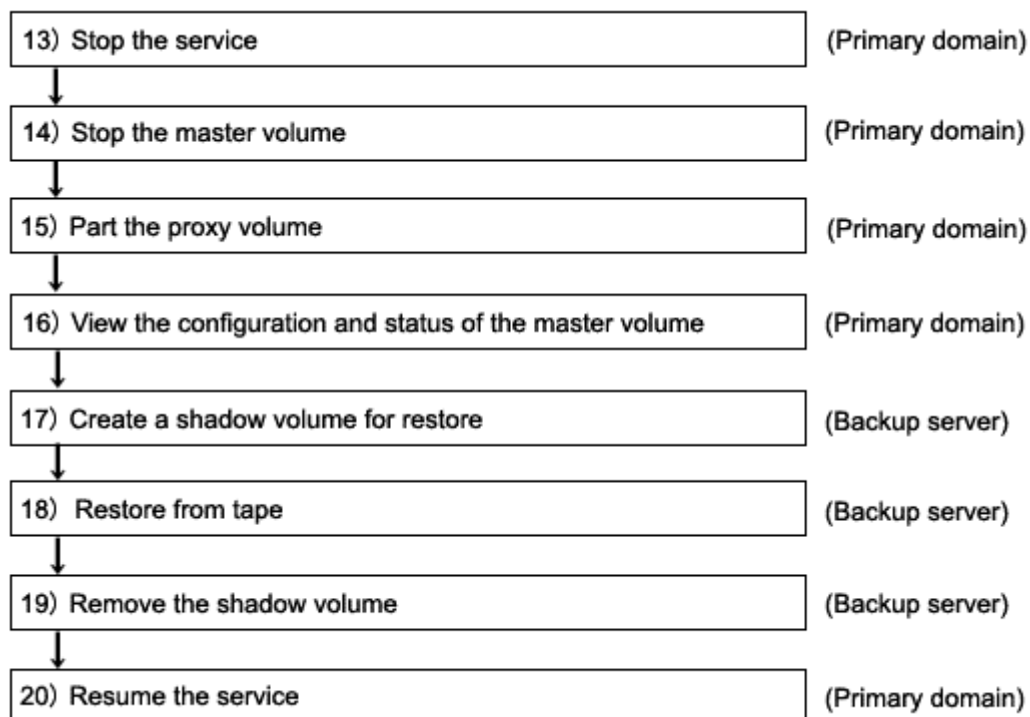

Figure: Outline of the Procedure for Restoring from Tape



6.3.3.6 Configuring an Environment



Note Automatic Resource Registration

Disks that are registered as resources in the primary domain or are to be registered with a shadow class in the backup domain may not be involved in the resource registration in the backup domain. For details about the automatic resource registration, see “Appendix H Register shared disk units.”

1) Creating a master volume

In the primary domain, create the master volume that is used for the services operation.

The following example creates mirror group Group1 that consists of disks sda and sdb to shared class Class1 that is shared on nodes Node1 and Node2 and creates mirror volume Volume1.

```
# sdxdisk -M -c Class1 -a type=shared,scope=Node1:Node2 -d  
sda=Disk1,sdb=Disk2  
# sdxdisk -C -c Class1 -g Group1 -d Disk1,Disk2  
# sdxvolume -M -c Class1 -g Group1 -v Volume1 -s 1048576
```

2) Creating and joining a proxy group

Create a proxy volume as the copy destination of the master volume and join it to the master volume in the primary domain. The following settings are necessary on Node1 or Node2 in the primary domain.

2-1) Creating a proxy volume

Create a proxy volume in the same size as master volume Volume1 to shared class Class1 to which Volume1 belongs.

The following example creates mirror group Group2 that consists of only disk sdc and creates mirror volume Volume2.

```
# sdxdisk -M -c Class1 -d sdc=Disk3  
# sdxdisk -C -c Class1 -g Group2 -d Disk3  
# sdxvolume -M -c Class1 -g Group2 -v Volume2 -s 1048576
```

2-2) Stopping the proxy volume
Stop proxy volume Volume2 on all nodes.

```
# sdxvolume -F -c Class1 -v Volume2 -e allnodes
```

2-3) Joining the proxy volume
Relate and join proxy volume Volume2 to master volume Volume1.

```
# sdxproxy Join -c Class1 -m Volume1 -p Volume2
```

After returning from the command, synchronization copying from Volume1 to Volume2 is executed, and as a result, they become synchronized.

6.3.3.7 Backing Up

3) Parting the proxy volume

Part the proxy volume from the master volume. The following procedure must be performed on Node1 or Node2 in the primary domain.



Information

The following example secures data consistency by stopping the services when the proxy volume is parted. Steps 3-2) and 3-4) are not required if software, such as a file system and a database system, that manages volume data provides functionality ensuring data consistency or repairing consistency for a parted volume is present. Alternatively, data consistency must be secured with the method specific to that software. For details, see "A.2.15 Ensuring Integrity of Snapshot Data."

3-1) Viewing the status of the proxy volume
Confirm that master volume Volume1 and proxy volume Volume2 are in sync with each other.

Confirm that proxy volume Volume2 is in the joined state. If Join is displayed in the PROXY field, the proxy volume is in the joined state.

```
# sdxinfo -V -c Class1 -o Volume2 -e long
OBJ  NAME  TYPE  CLASS  GROUP  DISK  MASTER  PROXY  ...
-----
volume *      mirror Class1  Group2  *      *      *      ...
volume Volume2 mirror Class1  Group2  *      Volume1 Join ...
volume *      mirror Class1  Group2  *      *      *      ...
```

Confirm that data in all the slices of proxy volume Volume2 is valid (STOP).

```
# sdxinfo -S -c Class1 -o Volume2
OBJ CLASS GROUP DISK VOLUME STATUS
-----
slice Class1 Group2 Disk3 Volume2 STOP
```

If data is not valid (STOP), repair the slice status referring to "F.1.1 Slice Status Abnormality."

3-2) Stopping the services

To secure consistency of data in proxy volume Volume2 parted, exit all applications using master volume Volume1 on Node1 and Node2.

When Volume1 is used as a file system, it should be unmounted.

3-3) Parting the proxy volume

Part proxy volume Volume2 from master volume Volume1.

```
# sdxproxy Part -c Class1 -p Volume2 -a pjrm=off
```



Note Just Resynchronization Mode for Proxy

On backup server Node3, data may be written from Node3 into Volume2 when data in Volume2 is backed up to tape. GDS in the primary domain cannot recognize the write occurrence from Node3. Consequently, if the JRM mode for proxies of the parted volume is on, the portions updated from Node3 may not be involved in resynchronization copying performed when the proxy volume is rejoined or restored. If this happens, synchronization of master volume Volume1 and proxy volume Volume2 is no longer ensured. For this reason, the JRM mode of a parted proxy volume must be set to off in advance.

When synchronization copying between a master and a proxy is conducted by the disk unit's copy function, the disk unit's copy function recognizes such a written occurrence from Node3. In this case, only the difference between the master and the proxy is copied through synchronization copying with the disk unit's copy function when the proxy is rejoined regardless of the value specified to the JRM mode for proxies. However, synchronization copying on restore is conducted by the soft copy function. Therefore, the JRM mode of a parted proxy volume should be set to off in advance.

3-4) Resuming the services

When the file system was unmounted in step 3-2), mount it again.

Resume the application stopped in step 3-2).

3-5) Stopping the proxy volume

To prevent improper access to proxy volume Volume2, stop Volume2.

```
# sdxvolume -F -c Class1 -v Volume2 -e allnodes
```

4) Viewing the configuration of the proxy volume

On Node1 or Node2 in the primary domain, view the configuration of proxy volume Volume2 that is the backup target.

```
# sdxinfo -c Class1 -o Volume2
# sdxinfo -c Class1 -o Volume2 -e long
```

5) Creating a shadow volume for backup

On backup server Node3, create a volume for backup (shadow volume).

```
# sdxshadowdisk -M -c Class2 -d c1t1d3=Disk3
# sdxshadowdisk -C -c Class2 -g Group2 -d Disk3
# sdxshadowvolume -M -c Class2 -g Group2 -v Volume2 -s 1048576
```



Note

Master volume data may be damaged if data is written into a shadow volume in improper configuration. Be sure to confirm that the shadow volume configuration is proper using the sdxinfo command.



Point

- The shadow volume must be created in the same configuration as the proxy volume created in step 2).
- The shadow disk name must correspond to the disk name assigned in the primary domain. The disk names assigned in the primary domain can be viewed in the NAME field for disk information displayed with the sdxinfo command in step 4).
- The class, the group, and the volume can be assigned any name.
- The order of connecting shadow disks to a shadow group must correspond to the order of connecting disks to a group in the primary domain. The order of connecting disks in the primary domain can be viewed in the DISKS field for group information displayed with the sdxinfo command in step 4).
- The stripe width of a shadow group must correspond to the stripe width in the primary domain. The stripe width specified in the primary domain can be viewed in the WIDTH field for group information displayed with the sdxinfo -e long command in step 4).
- The shadow volume must be created in the size corresponding to the proxy volume size. The proxy volume size can be viewed in the BLOCKS field for volume information displayed with the sdxinfo command in step 4).
- If there are multiple volumes, the corresponding shadow volumes must be created in the order of ascending values (first block numbers) in the 1STBLK field for volume information displayed with the sdxinfo command in step 4).

6) Backing up to tape

On backup server Node3, back up data in the shadow volume to tape. In the following examples, back up data in shadow volume Volume2 to a tape medium of tape device /dev/st0.



See

For details about the backup method, see manuals of a file system to be backed up and used commands.

6a) When backing up data held in a raw device with the dd(1) command

```
# dd if=/dev/sfdsk/Class2/rdisk/Volume2 of=/dev/st0 bs=32768
```

6b) When backing up a ext3 file system with the tar(1) command

6b-1) Activate shadow volume Volume2 in the read and write access mode (rw).

```
# sdxshadowvolume -F -c Class2 -v Volume2
# sdxshadowvolume -N -c Class2 -v Volume2 -e mode=rw
```

6b-2) Check and repair consistency of the ext3 file system on shadow volume Volume2. If the file system was unmounted when the proxy volume was parted in step 3), this step can be skipped.

```
# fsck -t ext3 -y /dev/sfdsk/Class2/dsk/Volume2
```

6b-3) Mount the ext3 file system on shadow volume Volume2 on /mnt1, a temporary mount point, in the read only mode.

```
# mkdir /mnt1
# mount -t ext3 -o ro /dev/sfdsk/Class2/dsk/Volume2 /mnt1
```

6b-4) Back up data held in the file system to tape.

```
# cd /mnt1
# tar cvf /dev/st0 .
```

6b-5) Unmount the file system mounted in step 6b-3).

```
# cd /
# umount /mnt1
# rmdir /mnt1
```

7) Removing the shadow volume

After the backup process is complete, remove the shadow volume to prevent improper access to it. The following settings are necessary on backup server Node3.

```
# sdxshadowvolume -F -c Class2 -v Volume2
# sdxshadowvolume -R -c Class2 -v Volume2
# sdxshadowgroup -R -c Class2 -g Group2
# sdxshadowdisk -R -c Class2 -d Disk3
```

8) Rejoining the proxy volume

Rejoin the proxy volume to the master volume. The following procedure must be performed on Node1 or Node2 in the primary domain.

8-1) Rejoining the proxy volume

Rejoin proxy volume Volume2 to master volume Volume1.

```
# sdxproxy Rejoin -c Class1 -p Volume2
```

After returning from the command, synchronization copying from Volume1 to Volume2 is executed.

8-2) Viewing the copy status

The status of synchronization copying can be viewed using the sdxinfo -S command. The slice of proxy volume Volume2 as the copy destination is in COPY status if copying is in progress and it will be in STOP status after the copy process ends normally.

```
# sdxinfo -S -c Class1 -o Volume2
OBJ CLASS GROUP DISK VOLUME STATUS
-----
slice Class1 Group2 Disk3 Volume2 STOP
```

6.3.3.8 Restoring from a Proxy Volume

9) Stopping the services

Exit all applications using master volume Volume1 on Node1 and Node2 in the primary domain.

When Volume1 is used as a file system, it should be unmounted.

10) Stopping the master volume

Stop master volume Volume1 on Node1 and Node2 in the primary domain. Execute the following command on Node1 or Node2.

```
# sdxvolume -F -c Class1 -v Volume1 -e allnodes
```

11) Restoring from the proxy volume

In the primary domain, restore data from proxy volume Volume2 back to master volume Volume1. Execute the following command on Node1 or Node2.

```
# sdxproxy RejoinRestore -c Class1 -p Volume2
```

After returning from the command, synchronization copying from Volume2 to Volume1 is executed.

12) Resuming the services

After synchronization copying is started from proxy volume Volume2 to master volume Volume1 in step 11), the services can be resumed before the copy process is completed. The following procedure must be performed on the node that runs the services.

12-1) Activating the master volume

Activate master volume Volume1.

```
# sdxvolume -N -c Class1 -v Volume1
```

12-2) Resuming the services

When the file system on master volume Volume1 was unmounted in step 9), mount it again. Launch the applications that use Volume1.

12-3) Viewing the copy status

The status of synchronization copying from proxy volume Volume2 to master volume Volume1 executed in step 11), can be viewed using the `sdxinfo -S` command. The slice of master volume Volume1 as the copy destination is in COPY status if copying is in progress and it will be in ACTIVE status after the copy process ends normally.

```
# sdxinfo -S -c Class1 -o Volume1
OBJ CLASS GROUP DISK VOLUME STATUS
-----
slice Class1 Group1 Disk1 Volume1 ACTIVE
slice Class1 Group1 Disk2 Volume1 ACTIVE
```



Information

Master volume Volume1 and proxy volume Volume2 are made the joined state through step 11). If data in Volume1 is damaged while they are in the joined state, the proxy data is also damaged. Thus data cannot be restored from Volume2 back to Volume1. Therefore, once the synchronization copying from Volume2 to Volume1 is complete, it is recommended to part Volume2 from Volume1. For details about the procedure for parting a proxy volume, see step 3) described in “6.3.3.7 Backing Up.”

6.3.3.9 Restoring from Tape

This sub-section shows an example that access can be gained from backup server Node3 to all of the disks constituting master volume Volume1.



Information When Using a Disk Unit's Copy Function

When access can be gained from backup server Node3 to all of the disks constituting master volume Volume1 and the disk unit's copy function is used to synchronize a master and a proxy, parting the proxy volume in step 15) is not required.



Information When access cannot be gained from the backup server to the disks constituting the master volume

While proxy volume Volume2 is parted, copy data from tape to the proxy volume, and then restore master volume data using the proxy volume.

13) Stopping the services

Exit all applications using master volume Volume1 on Node1 and Node2 in the primary domain.

When Volume1 is used as a file system, it should be unmounted.

14) Stopping the master volume

On Node1 and Node2 in the primary domain, stop master volume Volume1 to prevent improper access to it. Execute the following command on Node1 or Node2.

```
# sdxvolume -F -c Class1 -v Volume1 -e allnodes
```

15) Parting the proxy volume

In the primary domain, part proxy volume Volume2 from master volume Volume1. Execute the following command on Node1 or Node2.

```
# sdxproxy Part -c Class1 -p Volume2 -a pjrm=off
```



Note Just Resynchronization Mode for Proxy

After data held in master volume Volume1 is restored from tape on backup server Node3, proxy volume Volume2 is supposed to be rejoined to master volume Volume1. At this point the entire Volume1 data must be copied to Volume2. For this reason, the JRM mode of a parted proxy volume must be set to off in advance.



Information When Using a Disk Unit's Copy Function

When the disk unit's copy function is used to synchronize a master and a proxy, this procedure (parting a proxy) is not required.



Information When access cannot be gained from the backup server to the disks constituting the master volume

After proxy volume Volume2 is parted, inactivate Volume2 on Node1 and Node2 to prevent Volume2 from being written in improperly.

16) Viewing the status and configuration of the master volume

On Node1 and Node2 in the primary domain, view the configuration and status of master volume Volume1 that is the restore target. Confirm that all of the slices constituting Volume1 are in STOP status. If the status of a slice is invalid, repair it referring to "F.1.1 Slice Status Abnormality."

```
# sdxinfo -S -c Class1 -o Volume1
OBJ CLASS GROUP DISK VOLUME STATUS
-----
slice Class1 Group1 Disk1 Volume1 STOP
slice Class1 Group1 Disk2 Volume1 STOP
```



Information When Using a Disk Unit's Copy Function

When the proxy volume was not parted in step 15) because the disk unit's copy function is used for synchronizing a master and a proxy, you must also confirm that all of the slices constituting proxy volume Volume2 are in STOP status.



Information When access cannot be gained from the backup server to the disks constituting the master volume

View the configuration and the status of proxy volume Volume2 that is the restore target.

17) Creating a shadow volume for restore

On backup server Node3, create a volume for restore (shadow volume).

17-1) Creating a shadow volume

```
# sdxshadowdisk -M -c Class2 -d sda=Disk1,sdb=Disk2
# sdxshadowdisk -C -c Class2 -g Group1 -d Disk1,Disk2
# sdxshadowvolume -M -c Class2 -g Group1 -v Volume1 -s 1048576
```



Note

Master volume data may be damaged if data is written into a shadow volume in improper configuration. Be sure to confirm that the shadow volume configuration is proper using the sdxinfo command.



Point

- The shadow volume must be created in the same configuration as the master volume created in step 1).
- The shadow disk name must correspond to the disk name assigned in the primary domain. The disk names assigned in the primary domain can be viewed in the NAME field for disk information displayed with the sdxinfo command in step 16).
- The class, the group, and the volume can be assigned any name.
- The order of connecting shadow disks to a shadow group must correspond to the order of connecting disks to a group in the primary domain. The order of connecting disks in the primary domain can be viewed in the DISKS field for group information displayed with the sdxinfo command in step 16).
- The stripe width of a stripe type shadow group must correspond to the stripe width of a stripe group in the primary domain. The stripe width in the primary domain can be viewed in the WIDTH field for group information displayed with the sdxinfo -e long command in step 16).
- A shadow volume must be created in the size corresponding to the master volume size. The master volume size can be viewed in the BLOCKS field for volume information displayed with the sdxinfo command in step 16).
- If there are multiple volumes, the corresponding shadow volumes must be created in the order of ascending values (first block numbers) in the 1STBLK field for volume information displayed with the sdxinfo command in step 16).



Information When access cannot be gained from the backup server to the disks constituting the master volume

Create a shadow volume for restore in a similar procedure that created a proxy volume in step 2).

17-2) Setting the access mode of the shadow volume

Activate shadow volume Volume1 in the read and write access mode (rw).

```
# sdxshadowvolume -F -c Class2 -v Volume1
# sdxshadowvolume -N -c Class2 -v Volume1 -e mode=rw
```

17-3) Viewing the configuration of the shadow volume

Using the `sdxinfo` command, confirm that the group configuration and the volume configuration are proper based on group information in the DISKS field, volume information in the 1STBLK field and in the BLOCKS field and so on.

```
# sdxinfo -c Class2
```

18) Restoring from tape

On backup server Node3, restore shadow volume data from tape to which it was backed up in step 6). In the following examples, restore data held in shadow volume Volume1 from a tape medium of tape device /dev/st0.



See

For details about the restore method, see manuals of a file system to be restored and used commands.

18a) When restoring data held in a raw device with the `dd(1)` command

```
# dd if=/dev/st0 of=/dev/sfdsk/Class2/rdisk/Volume1 bs=32768
```

18b) When restoring a ext file system with the `tar(1)` command

18b-1) Create a ext3 file system to shadow volume Volume1.

```
# mkfs -t ext3 /dev/sfdsk/Class2/dsk/Volume1
```

18b-2) Mount the ext3 file system on shadow volume Volume1 on /mnt1, a temporary mount point.

```
# mkdir /mnt1  
# mount -t ext3 /dev/sfdsk/Class2/dsk/Volume1 /mnt1
```

18b-3) Restore data held in the file system from tape.

```
# cd /mnt1  
# tar xvf /dev/st0
```

18b-4) Unmount the file system mounted in step 18b-3).

```
# cd /  
# umount /mnt1  
# rmdir /mnt1
```

19) Removing the shadow volume

After the restore process is complete, remove the shadow volume to prevent improper access to it. The following settings are necessary on backup server Node3.

```
# sdxshadowvolume -F -c Class2 -v Volume1  
# sdxshadowvolume -R -c Class2 -v Volume1  
# sdxshadowgroup -R -c Class2 -g Group1  
# sdxshadowdisk -R -c Class2 -d Disk1  
# sdxshadowdisk -R -c Class2 -d Disk2
```

20) Resuming the services

Resume services in the primary domain. The following procedure must be performed on the node that runs the services.



Information When access cannot be gained from the backup server to the disks constituting the master volume

Before the services are resumed, restore data from proxy volume Volume2 to master volume Volume1. For the procedure see "6.3.3.8 Restoring from a Proxy Volume."

20-1) Activating the master volume

Activate master volume Volume1.

```
# sdxvolume -N -c Class1 -v Volume1
```

20-2) Resuming the services

When the file system on Volume1 was unmounted in step 13), mount it again. Launch the applications that use Volume1.